

STONES

Stones are derived from rock.

Classification of rock:

Rocks are classified in 3 ways.

- i) Geological Classification.
- ii) Physical Classification.
- iii) Chemical Classification.

(i) Geological Classification:-

Geologically, rocks are divided into 3 types.

- a) igneous rocks.
- b) Sedimentary rocks.
- c) metamorphic rocks.

a) igneous rocks:-

- The inside portion of earth's surface has high temp. so as to cause fusion by heat at even ordinary pressures. The molten is known as magma & this magma occasionally tries to come out to earth's surface through cracks.

- The rocks, which're formed on cooling of these magma're known as igneous rocks.

- Ex:- Granite.

- It's again divided into 3 types:-

* volcanic rocks:-

- These rocks are formed on earth's surface due to cooling of magma released by volcanoes. As the cooling process is fast, these rocks are extremely fine grained & glassy.

- Ex:- Basalt & trap.

* Hypabyssal rocks:-

- These rocks are formed due to cooling of magma at a shallow depth from earth's surface. Cooling process is slow & these rocks have a fine grained crystalline structure.

- Ex:- Quartz, Diabase & Gneiss

* Plutonic rocks

- These rocks are formed due to cooling of magma at a considerable depth from earth surface. These are very strong & have a crystalline structure.

- Ex: gabbro, granite etc

b) Sedimentary rocks

- These rocks are formed by gradual deposition of disintegrated rocks (formed by erosion & transportation by water, wind, gravity etc.), vegetable matter at a particular place over a period of time.

- Ex: limestone, sandstone etc
- These are called stratified rocks as these rocks are formed in layers.

c) Metamorphic rocks

- These rocks are formed from igneous or sedimentary rocks, when these rocks are s.t. great heat and pressure, & this process is called metamorphism.

- Ex: limestone changes to marble
- Slate changes to gneiss etc

- There are 4 types of metamorphism.

- * Thermal metamorphism → heat
- * Cataclastic " → pressure
- * Diagenetic " → heat & stress
- * Plutonic " → heat & uniform pressure

(ii) Physical classification

Physically, rocks are divided into 3 types.

- a) Stratified rocks
- b) Unstratified "
- c) Foliated "

a) Stratified rocks -

- These rocks exhibit/show distinct layers of separation. The plane along these separation layers are called cleavage plane.

- Ex- limestone, slate, sand stone etc

(Sedimentary rocks)

b) Unstratified rocks -

- These rocks don't show any layers of separation through which they can be split. These are compact granular or crystalline granular in

Structure.

- Ex- granite, trap

c) Foliated rocks -

- These rocks have a tendency to split in a definite direction only.

- Ex- metamorphic rocks.

(iii) Chemical Classification -

Chemically, rocks are divided into 3 types.

a) Silicious rocks -

b) Argillaceous rocks

c) Calcareous rocks

a) Silicious rocks -

- In these rocks, silica is the main constituent.

- They are hard & durable.

- These rocks are not easily affected by weathering agencies.

- Silica can exist in free form or combined form. In free form, silica is called sand & in combined form, it's called silicate. Rocks

containing silica in free form are hard, while rocks containing silica in combined form are likely to be disintegrated.

- Ex- Sandstone, quartzite etc

b) Argillaceous rocks -

- These rocks contain clay as main constituent. i.e. alumina.

- hard & strong but brittle.

- Ex -> slate, Kaolinite etc

c) Calcareous rocks -

- In these rocks, Calcium Carbonate is the main constituent. i.e. lime

- These rocks are not very durable & their durability depends on the surrounding atmosphere

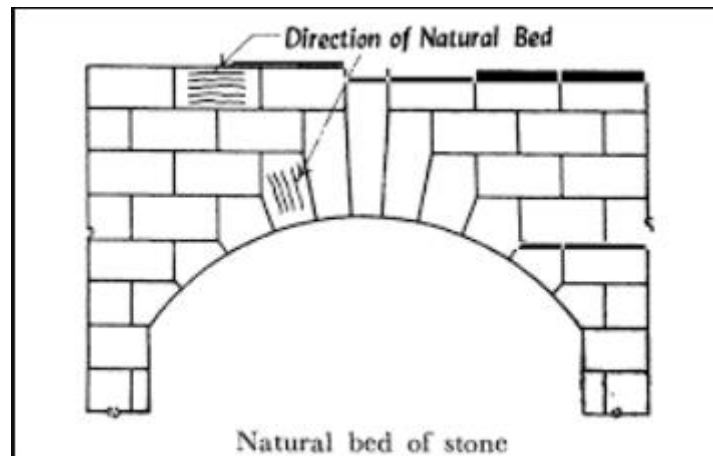
- Ex -> limestone & marble.

Uses of stones: -

1. Construction of residential and public buildings
2. Construction of dams, weirs, harbors, abutments for bridges etc.
3. Facework of structures where massive appearance, solidity of construction and ornamental features are desired.
4. Used as road metal and railway ballast
5. Used as aggregate for concrete
6. Used in the form of veneers for decorative front and interior of buildings

Natural bed of stone: -

1. These are the distinct planes of division along which rocks can easily be split
2. It is a general rule in stone masonry that to obtain maximum strength, stones are usually laid in a direction perpendicular to direction of these natural bed of stones
3. In arches the stones in the center are laid in radial direction and stones near the edges are laid horizontal and this arrangement gives maximum strength to the arch.



Qualities of good building stones: -

1. A good building stone should be of uniform color and free from clay holes, spots of other colors, bands etc.
2. Stones should have enough strength to resist the loads coming on it. Compressive strength of good building stones should be greater than 100N/mm^2 . (strength)
3. Building stones should be capable to resist the adverse effects of natural forces like wind, rain, heat etc. (durability)
4. Stones should be hard enough to resist the wearing and abrasive action. Hardness of stones is measured by Mohr's scale. (hardness)
5. Building stones should be strong enough to resist the impact forces caused by loads or heavy machines over them. (toughness)
6. the more the specific gravity of stones, the heavier the stones will be. Specific gravity of good building stones should be greater than 2.7.
7. building stones shouldn't be porous enough otherwise rain water will easily penetrate and damage the stones. Good building stones shouldn't absorb more than 60% of their weight after immersion in water after 24 hours.
8. Good building stones should be easy to dress them i.e. giving required shape to them.

9. Good building stones should be fire resistant i.e. they shouldn't catch fire easily.
10. Good building stones should be easily workable i.e. the overall cost of cutting, dressing and shaping should be minimum.

Dressing of stones: -

The art of cutting stones into required shapes, sizes and finishes for use in construction works is known as dressing of stones. The purposes of dressing of stones are: -

1. To get the desired appearance from stone work
2. To make the transport from quarry easy and economical
3. Suitable for different masonry works

Dressing can be divided into two types, they are

1. Quarry dressing
2. Site dressing

Quarry dressing is considered to be more advantageous because of following reasons:-

1. At quarry site, it is easy to get cheap labour for the process of dressing of stones
2. Irregular and rough portions of stones are removed at quarry site which decreases the weight of stones and it also facilitates easy transportation of the stones.
3. The stones when quarried contain quarry sap and hence they are comparatively soft and can be easily dressed.



(quarrying site of stones)



(dressing of stones)

Different types of finishes are obtained using dressing of stones, they are: -

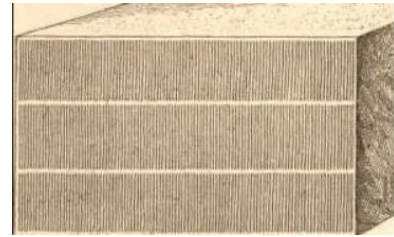
- Axed finish: -

This type of finishes is used in hard stones like granite, where the dressing is done with the help of axes, hence such finishes are called axed finish.



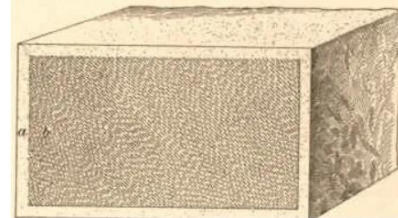
- Boasted or droved finish: -

In this type of finish, boaster and hammer is used to make noncontinuous parallel marks on stone surfaces. These marks may be horizontal, inclined or vertical.



- Chisel-draughted margins: -

In order to obtain uniform joints in stonewalls, the margins are placed which may be either squared, pitched or chamfered.



- Circular finish: -

In this type of finish, stone surfaces are made round or circular as in case of a column.



- Dragged or combed finish: -

This finish is used on soft stones. This is made by a drag or a comb which is a piece of steel with a no of teeth, is rubbed on the surface in all directions.



- Furrowed finish: -

In this type of finish, a margin of about 20mm width is sunk on all the edges of stone and the centre portion is made to project about 15mm. a no of vertical or horizontal grooves about 10mm wide are formed on the projected portion.



- Molded finish: -

The surface of stone can be molded into any desired shape to improve the appearance of the work. The molding can either be done with hand or machine.



- Hammer dressed finish: -

in this type of finish, the stones are made roughly square or rectangular by means of a Waller's hammer. The hammer dressed stones have a regular and well-defined corner which fits well in the masonry.



- Plain finish: -

In this type of finish, the surface of stone is made approximately smooth using saw or a chisel.



- Polished finish: -

This type of finish is used in marbles, granites etc. these are polished either manually or using machines. A glassy surface is obtained.



- Reticulated finish: -

This type of finish presents a net like appearance. A margin of about 20mm is marked on the edges of stone and irregular sinking's are made on the enclosed area.



- Punched finish: -

In this type of finish, the exposed surface of stone is dressed with the help of a punch, thus making punch holes at some regular distance apart. A 25mm strip is made around the perimeter of stone with chisel.



- Rubbed finish: -

This type of finish is obtained by rubbing the surface of stone with another hard surface or with any machine. The rubbing is done by using water and sand



- Tooled finish:-

The stone surface is finished by means of a chisel and parallel continuous marks, either horizontal or inclined or vertical are left on the surface.



- Scabbling finish:-

This is a type of rough dressing in which irregular projections are removed by a scabbling hammer.



- Vermiculated finish:-

This finish is similar to reticulated finish except the sinking in this case is more curved and is like worm eaten appearance.



- Quarry faced finish:-

These are the stones which have a smooth surface and don't require any dressing. These stones are sometimes directly available from quarrying. These are also called self-faced or rock-faced stones.



- Sunk finish:-

This finish is obtained by depressing the original surface of stone into wide grooves, marks, inclined surfaces etc.



Characteristics of different types of stones and their uses:-

Sl. No.	Name of the stones	uses
1	Basalt	<ul style="list-style-type: none"> • Also known as trap • Comp strength = 200mpa to 350mpa Commonly used in <ul style="list-style-type: none"> • Road construction

		<ul style="list-style-type: none"> • As aggregate in concrete production • Rubble masonry works for bridge piers, river walls and dams
2	Granite	<ul style="list-style-type: none"> • Construction works of bridge piers, retaining walls, stone columns • As aggregate in concrete • Ballast for railways • Monumental utilizations etc • Comp strength = 100mpa to 250mpa
3	Sandstone	<ul style="list-style-type: none"> • Used for construction of heavy structures • Dams, bridges, river walls • Composed of quartz and feldspar and found in different colors • Comp strength = 20mpa to 170mpa • Sp. Gravity = 1.85 to 2.7
4	Slate	<ul style="list-style-type: none"> • Roofing tiles, slabs and pavements • Consists of quartz, mica and clay minerals • Comp strength = 100mpa to 200mpa • Sp. Gravity = 2.6 to 2.7
5	Limestone	<ul style="list-style-type: none"> • Used for flooring, roofing, pavements and as a base material for cement. • Color=white
6	Laterite	<ul style="list-style-type: none"> • Contains high percentage of iron oxide, hence color is red • Can be easily cut into blocks • Used as a building stone
7	Marble	<ul style="list-style-type: none"> • Used for facing and ornamental works in columns, floorings and steps. • Comp strength = 70mpa to 75mpa • Easily cut and carved into different shapes. • Available in diff colors like white, pink etc
8	Gneiss	<ul style="list-style-type: none"> • Used for minor construction due to presence of deleterious substances • Color may be light gray, pink, purple etc
9	Quartzite	<ul style="list-style-type: none"> • Used as building blocks, slabs, as aggregate for concrete etc. • Mainly composed of mica and feldspar in small quantities. • Available in diff colors like white, gray, yellow etc.

CHAPTER 2

BRICKS

1. Bricks are the most commonly used construction materials.
2. Bricks are prepared by moulding clay in rectangular blocks of uniform size and then drying and burning these blocks.

Composition of good brick earth: -

To get good quality bricks, a good brick earth should contain following constituents.

1. Silica (SiO_2)
2. Alumina (Al_2O_3)
3. Lime (CaCO_3)
4. Iron oxide (Fe_2O_3)
5. Magnesia (MgO)

Silica: -

- A good brick earth should contain 50 – 60% of silica
- It prevents cracking, shrinking and warping of raw bricks
- It also affects the durability of bricks
- If present in excess, it destroys the cohesion between particles and bricks become brittle

Alumina: -

- A good brick earth should contain 20 – 30% of alumina
- It imparts plasticity which helps in moulding of the brick earth
- If present in excess, it makes raw bricks shrink and warp during drying

Lime: -

- A good brick earth should contain 5 – 10% of lime
- It prevents shrinkage of bricks on drying
- It helps silica in clay to melt and thus helps to bind it
- If present in excess, it causes the brick to melt and brick loses its shape

Iron oxide: -

- A good brick earth should contain 5 – 6% of iron oxide
- It gives red color to bricks
- If present in excess, the color of bricks become dark blue or blackish and the brick becomes yellowish if present in less amount
- It gives strength and hardness to bricks

Magnesia: -

- A good brick earth should contain magnesia less than 1%
- It imparts yellow tint to the bricks
- Excess magnesia leads to decay of bricks
- Also helps in reducing shrinkage

Manufacturing of bricks: - the process of manufacturing of bricks is broadly divided into following steps, they are: -

- Preparation of clay
- Moulding

CHAPTER 2

BRICKS

- Drying
- Burning

Preparation of clay: - the clay for bricks is made in following order

- Unsoiling: - the top layer of the soil, about 200 mm depth of soil is taken out and thrown away because top soil contains impurities which is unsuitable for making bricks.
- Digging: - the clay is then dug out from the prepared ground surface and placed in heaps about 600-1200mm height.
- Cleaning: - the dug-out clay is cleaned of vegetable matters, pebbles, stones etc. if these materials are in excess, then clay may be washed and screened.
- Weathering: - then the clay is exposed to atmosphere for softening and mellowing. This period may vary from several weeks to full season.
- Blending: - it is the process in which the clay is mixed sufficiently by turning it up-down to make it ready for the next stage of tempering. Any extra material to be added is spread on top and mixed properly.
- Tempering: - it is the process of bringing clay to a proper degree of hardness by mixing it with water to obtain clay of uniform character. Generally, kneading under the feet of men and cattle is done for tempering but for large scale clay, pug mill is used.

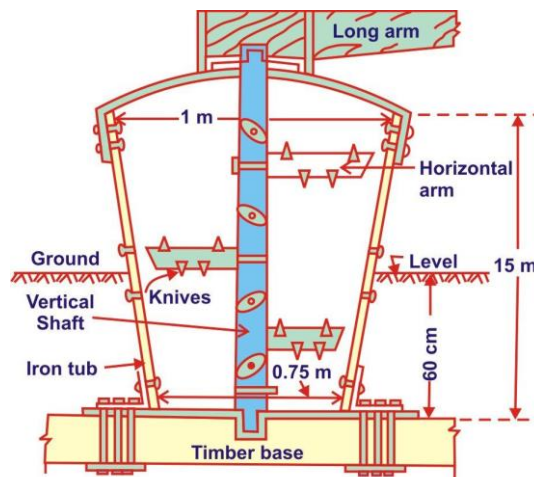


FIG. 2.1. Pug Mill.

A typical pugmill is shown in the above figure. It is a conical shaped iron-tub with 1000mm diameter at top and 750-800mm diameter at bottom. It has a fixed timber base at bottom except for the hole to take out the pugged earth. A vertical shaft with horizontal arms on which sharp and wedge-shaped knives fixed at regular intervals is provided. The vertical shaft is connected to long arm which is attached to a pair of bullocks. Clay with water is placed in the pugmill from top and thorough mixing of clay water mixture is carried out by the combined action of horizontal arms and knives. When the clay is sufficiently pugged, it is taken out by opening the hole at bottom. Then the pugged earth is taken to next operation of moulding.

- Moulding: - it is the process of giving a brick shape to the pugged clay. It is done by two ways, they are
 - hand moulding
 - machine moulding

hand moulding: - in this moulding process, bricks are moulded by hand i.e. manually. It is suitable when bricks are to be manufactured in a small scale. It is adopted where

CHAPTER 2

BRICKS

manpower is cheap and is readily available. Moulds are rectangular boxes with opening at top and bottom made of wood, iron, steel etc. it is divided into two types: -

- ground moulded bricks
- table moulded bricks

ground moulded bricks: - in this process, bricks are moulded on level ground. First, fine sand is sprinkled over the ground, then the mould is dipped in water and placed. The clay is pressed in the mould in such a way clay fills all corners of the mould. The surplus clay is removed off the mould with a wooden strike. The mould is then lifted off the ground by leaving raw brick. Same process is repeated till ground is covered with raw bricks. These bricks have a rough surface at bottom. Frog is a mark of depth about 15-20mm placed on raw bricks to serve following two purposes: -



- to indicate the name of the manufacturer
- to serve as a key for mortar when next brick is placed over it

table moulded bricks: - the process of moulding bricks is similar to ground moulded bricks but in this process, the mould is placed on a table of size 2m x 1m. in this process, the efficiency of moulder decreases over time because of standing for longer duration at same place. Cost of brick also increase due to table moulding.



Machine moulding: - in this process, moulding is done using machines, bricks are cut by wires fixed on frames, thus these bricks also called wire-cut bricks. Bricks with sharp edges are obtained by such method. It is of two types: -

- plastic clay machines
 - dry clay machines
- drying: - bricks are to be dried properly before they are taken to the next operation of burning. Because if damp bricks are to be burnt, they are likely to be distorted. Bricks are laid along and across as shown in figure in stacks of width equal to two bricks. Drying is carried out about 3-10 days or till the moisture content reduces to approx. 2%.
- Burning: - dried bricks are burnt to gain hardness, strength, durability, density and red colour appearance. Bricks are burnt at a temp of 1100°C because at this high temp, fusion of sand and lime occurs. Temperature higher than this is not allowed as it will cause melting of bricks itself. Burning of bricks is done by two ways, they are: -

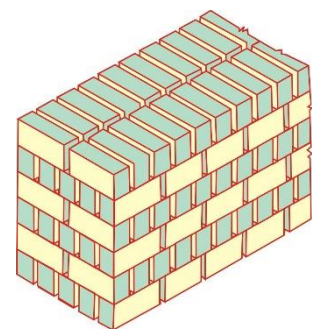


FIG. 2.6. Stack for drying of bricks.

- Clamp burning
- Kiln burning

CHAPTER 2

BRICKS

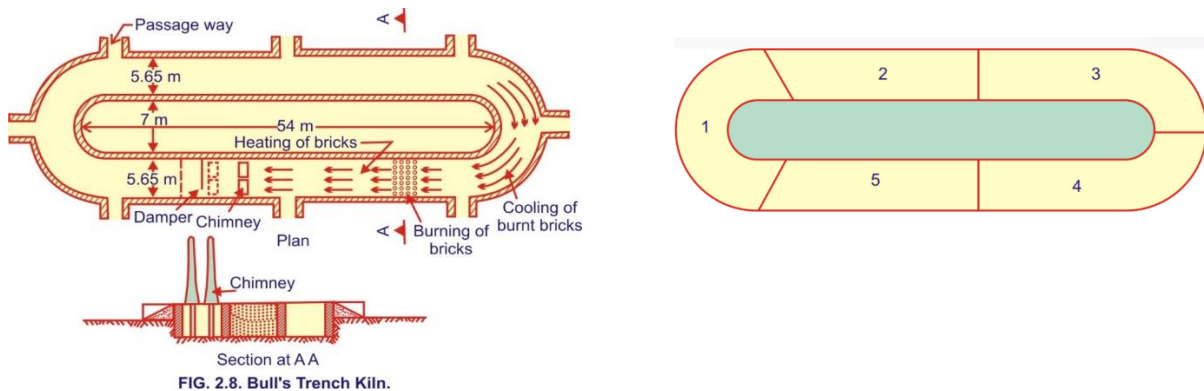
Kiln burning: - kiln is a large oven used for burning of bricks. Locally available materials like wood, coal, cow dung can be used as fuel. They are of two ways: -

- Intermittent kilns
- Continuous kilns

Continuous kilns: - these kilns are called continuous because the processes of loading, unloading, cooling, pre-heating take place at a time. These are used when bricks are to be produced on a large scale and in a short time. It is a first method of burning. This is of 2 types: -

- Bull's trench kiln
- Hoffman's kiln

Bull's trench kiln: - these are the most widely used continuous kilns in India and rectangular, circular or oval plan shape. They are constructed below the ground approx. 2m in depth by excavating a trench of required width for a given capacity of brick manufacturing. This trench is divided into different zones. The whole working is arranged so as to complete all the operations simultaneously.



To understand the working operation of Bull's trench kiln, let us divide the whole kiln into 5 zones. For first cycle of operations,

Zone 1: burnt bricks being cooled.

Zone 2: bricks being burnt.

Zone 3: loaded sundried bricks being heated by hot air from zone 2.

Zone 4- Fresh sundried bricks being loaded.

Zone 5- Cooled bricks being unloaded and similarly, the processes are shifted to next zones respectively until all the bricks are being burnt.

Advantages: -

- It gives continuous supply of bricks
- It gives high % of 1st class bricks

Disadvantages: -

- Its initial cost is high

CHAPTER 2

BRICKS

- Needs constant skilled supervision and operation
- Doesn't have any roof hence difficult to operate in rainy seasons

Hoffman's kiln: (Explain with sketch and upload on classroom folder)

- Differentiate between bull's trench kiln and hoffman's kiln (upload on classroom folder)

Classification of bricks: - bricks are broadly divided in to two categories, they are:

- Unburnt or sun-dried bricks
- Burnt bricks

unburnt bricks / sun dried bricks	Burnt bricks
<ul style="list-style-type: none"> • dried with the help of heat received from sun after moulding. • These aren't burnt in clamp or kiln. • Used for the construction of cheap and light structures. • Not suitable for use at places where heavy rain occurs. 	<ul style="list-style-type: none"> • Burnt in clamps or kilns • hard, strong and durable • used in construction of permanent structures. • Divided in to 4 classes: <ul style="list-style-type: none"> ○ 1st class bricks ○ 2nd class bricks ○ 3rd class bricks ○ 4th class bricks

1st class bricks	2nd class bricks
<ul style="list-style-type: none"> • Table moulded, burnt in kilns • Well burnt and regular in shape • Edges are sharp and well defined • Uniform colour • Surface is smooth, clean and free from cracks. • Clear metallic ringing sound produced when two bricks stuck against each other. • So hard that very difficult to make marks on surface using finger nail. • Water absorption less than 15% • Min crushing strength 10.5 Mpa • These are used for construction of load bearing walls, arches, coping, RB work etc. 	<ul style="list-style-type: none"> • Ground moulded, burnt in kilns • Well burnt and irregular in shape • Edges are neither well defined nor straight. • Doesn't have uniform colour • Surface is clean and free from cracks but has slight chips and flaws. • Emit ringing sound when stuck against each other. • Less hard • Water absorption less than 22% • Min crushing strength 7Mpa • These are used in normal masonry constructions and also as brick ballast in RCC work and lime concrete.

CHAPTER 2

BRICKS

3rd class bricks	4th class bricks
<ul style="list-style-type: none">• Ground moulded, burnt in clamps• Not well burnt and not uniform in shape and size• Has a light yellowish color• Edges are irregular and surface quite rough• Emit dull sound when stuck against each other• Water absorption is between 20% to 25%.• Used in construction of inferior and temporary structures also in the construction of boundary walls	<ul style="list-style-type: none">• Overburnt bricks that get overheated due to presence near fire in the kiln.• Irregular in shape and size• Has dark color• Hard and strong• Also called Jhama bricks / overburnt bricks• Create ringing sound when stuck against each other.• These are not normally used as building bricks instead used as aggregates for concrete in foundation, roads etc.

Size of traditional and modular bricks: -

- Standard or nominal size of a brick = 19cm x 9cm x 9cm
- Modular size of a brick = including 5mm mortar thickness all around the bricks, then 20cm x 10cm x 10cm
- Size of a traditional brick = 23cm x 11.4cm x 7.6cm

Qualities of good building bricks: -

- The bricks should be table-moulded, well burnt in kilns, copper-coloured, free from cracks and with sharp and square edges. The colour should be uniform and bright.
- The bricks should be uniform in shape and should be of standard size.
- The bricks should give a clear metallic ringing sound when struck with each other.
- The bricks when broken or fractured should show a bright homogeneous and uniform compact structure free from voids.
- The brick should not absorb water more than 20% by weight, for first class bricks and 22% by weight for second class bricks, when soaked in water for a period of 24 hours.
- The bricks should be sufficiently hard. No impression should be left on brick surface, when it is scratched with finger nail.
- The bricks should not break into pieces when dropped flat on hard ground from a height of about one meter.
- The bricks should have low thermal conductivity and they should be sound proof.
- The bricks, when soaked in water for 24 hours, should not show deposits of white salt when allowed to dry in shade.
- No bricks should have the crushing strength below 5.50 N/mm².

CEMENT

- Cement is a binder which bind other materials together when it sets and hardens.
- It was invented by an England mason Joseph Aspdin.
- Hydraulic cements set and hardens under water prepared by replacing some of the cement with activated aluminium silicates, pozzolanas like fly ash.

Physical properties of cement: -

- It gives strength to masonry
- An excellent binding material
- It is easily workable
- Offers good resistance to moisture
- Possesses good plasticity
- Stiffens or hardens early

Composition of cement: -

Mainly, cement contains two basic ingredients, they are: - argillaceous and calcareous materials. Clay predominates in argillaceous and calcium carbonate predominates in calcareous materials.

Ingredients	Percentage
• Lime (CaO)	• 62-67%
• Silica (SiO ₂)	• 17-25%
• Alumina (Al ₂ O ₃)	• 3-8%
• Calcium sulphate or Gypsum (CaSO ₄)	• 3-4%
• Iron oxide (Fe ₂ O ₃)	• 3-4%
• Magnesia (MgO)	• 1-3%
• Sulphur	• 1-3%
• Alkalies	• 0.2-1%

- Lime: -
 - it gives strength to cement and helps cement to set quickly
 - if present in excess, makes the cement unsound i.e. expansion or disintegration of cement occurs.
- Silica: -
 - it also imparts strength but if present in excess, increases the setting time of cement.
- Alumina: -
 - imparts quick setting property to cement
 - if present in excess, weakens the cement

CEMENT

- **Calcium sulphate: -**
 - it is also called gypsum
 - it helps in increasing the setting time of cement
- **Iron oxide: -**
 - imparts color, hardness and strength to cement
- **Magnesia: -**
 - imparts hardness and color to the cement
 - if present in excess, it makes the cement unsound
- **Sulphur: -**
 - it is useful in making cement sound
 - if present in excess, makes the cement unsound
- **Alkalies: -**
 - if present in excess, cause a no of troubles like alkali-aggregate reaction, efflorescence etc.

Bogues compounds: -

- tri calcium silicate (C₃S): - 3CaO. SiO₂, gives early strength to cement (7- 28 days strength)
- di calcium silicate (C₂S): - 2CaO. SiO₂, gives later strength (after 28 days) to cement.
- Tri calcium aluminate (C₃A): - 3CaO. Al₂O₃, gives initial strength (within 24 hours) to cement.
- Tetra calcium alumino ferrite (C₄AF): - 4CaO. Al₂O₃. Fe₂O₃



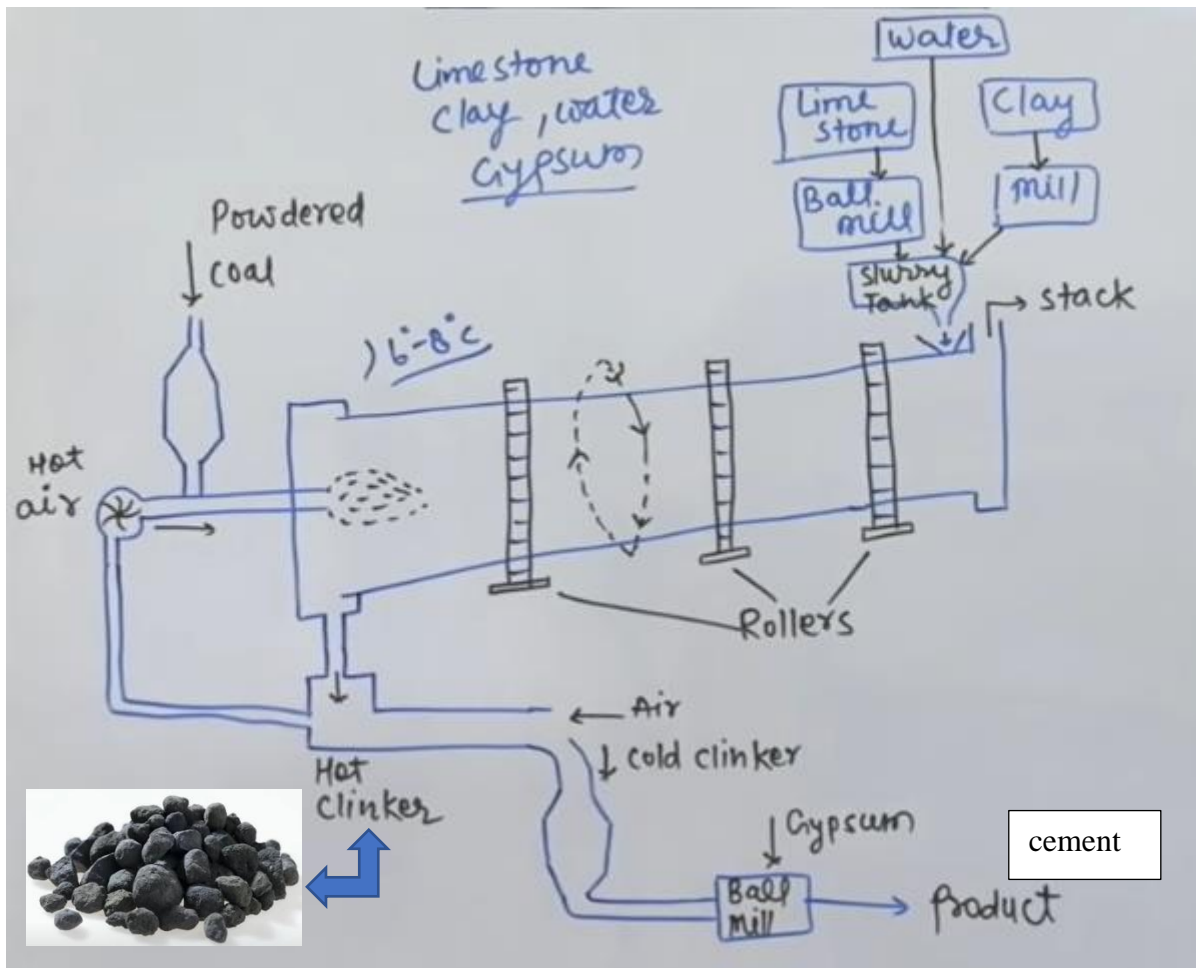
Manufacturing of cement: -

Cement can be manufactured by two processes, they are

- Dry process
- Wet process (**old method**)

The raw materials for manufacturing of cement are calcareous materials (limestone) and argillaceous materials (clay). If the mixing of these two raw materials is done in dry state, the process is called dry process and if they are mixed in wet condition i.e. in presence of water, the process is called wet process.

CEMENT



Types of cement: -

- OPC (Ordinary Portland cement); - initial setting time is 30 minutes and final setting time is 10 hours.
- RHPC (Rapid Hardening Portland Cement): - finer, more C_3S and less C_2S , 3 days strength of RHPC = 7 days strength of OPC
- LHPC (Low Heat Portland Cement): - low C_3S and C_3A , less heat of hydration and used in mass production i.e. dams, retaining walls etc.
- Blast furnace slag cement: - contains 60-65% of slag obtained from blast furnace. Economical as it uses the slag, which is a waste product.
- Sulphate resisting Portland cement: - low C_3A content, used where sulphate attack is expected.
- Fly ash Portland cement: - replacing 10-25% of flyash in OPC, economical, higher strength and resistance to chemicals.
- White cement: - less percentage of iron oxide
- Expansive cement: - presence of sulpho-aluminate, used in crack repairing works.
- High alumina cement: - limestone and bauxite are the raw materials, initial setting time is 3.5 hours and final setting time is 5 hours.

CEMENT

Sand

Sources of sand: - sand particles contain grains of silica (SiO_2). Different types of sand based on natural sources, they are

1. Pit sand
2. River sand
3. Sea sand

Pit sand: - these sands are obtained by forming pits of depth 1-2m in to the soil from ground level. These sands consist of sharp, angular grains and free from salts.

River sand: - these sands are obtained from river banks or beds. These sands consist of fine rounded grains. The color of these sands is mostly white. It is usually available in clean conditions and mostly used for different purposes.

Sea sand: - these sands are found along the seashores. It consists of rounded sand grains. The color of these sands is light brown. These sands contain salts. If used in construction works, creates problems like dampness, efflorescence and disintegration of work etc.

Classification of sand: - according to the size of grains, sand is classified in to 3 types: -

1. Fine sand
2. Coarse sand
3. Gravelly sand

Fine sand: - the sand passing through a screen of clear opening 1.5875mm is known as fine sand. It is used for plastering.

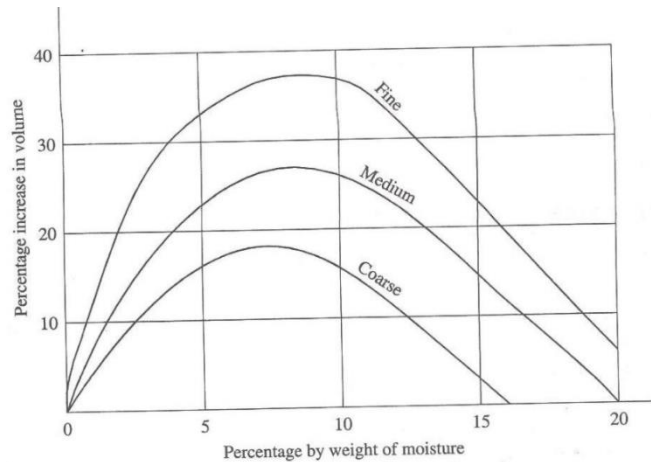
Coarse sand: - the sand passing through a screen of clear opening 3.175mm is known as coarse sand. It is used for masonry work.

Gravelly sand: - the sand passing through a screen of clear opening 7.62mm is known as gravelly sand. It is used for concrete work.

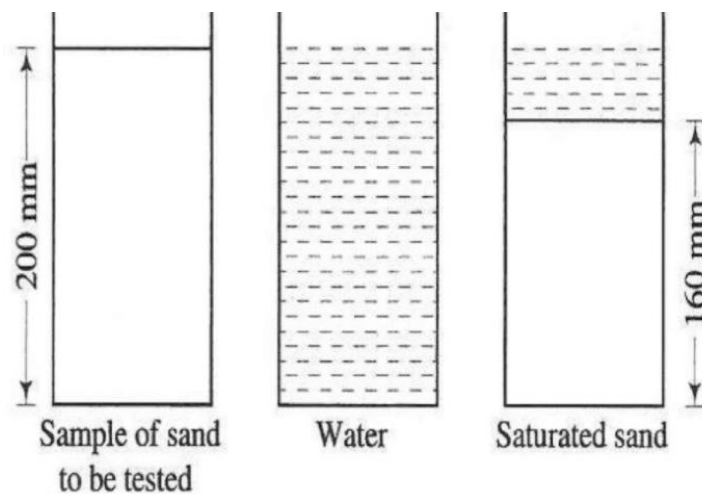
Bulking of sand: -

- The phenomenon of increase in volume of sand due to absorption of moisture from atmosphere is called bulking of sand. This is due to the fact that the moisture around sand particles creates a thin film of water which increases the volume of sand grains.
- The finer the sand, the more will be bulking.
- For a moisture increase from 5 to 8%, there will be an increase in volume from 20 to 40%.

Sand



- To calculate percentage bulking of sand, following test is done
- A container is taken and sand sample to be tested is filled up to two-third of height of container.
 - The height of sand sample is measured, let say 200mm.
 - The sand is taken out of container and care should be taken to avoid any loss of sand while taking out.
 - The container is filled with water and sand is slowly dropped in the container and stirred thoroughly by means of a rod.
 - The height of sand is measured, let say 160mm.



- Then, percentage of bulking = $\frac{(200-160)}{160} * 100 = \frac{1}{4}$ or 25%

Mortar

Definition: - it is prepared by mixing a binding material, fine aggregate and water in required proportion. The binding materials may be cement / lime, fine aggregate may be sand. Binding material and fine aggregate are also called matrix and adulterant respectively.

Classification of mortar: - based on the type of binding material used, mortar is classified into following types: -

i) cement mortar

ii) lime mortar

iii) gauged mortar

i) cement mortar: - In this mortar, cement is used as binding material. Proportion of cement to sand by volume varies from 1:2 to 1:6. It has high strength and good water resisting properties. It is used in the construction of underground structures.

ii) lime mortar: - in this mortar, lime is used as the binding material. Lime may be fat lime or hydraulic lime. Fat lime is the lime which increases in volume 2-3 times when water is added to it. Hydraulic lime is the lime which can set under water. It has high plasticity, good workability, high durability, less shrinkage and good cohesiveness compared to cement mortar.

iii) gauged mortar: - in this mortar, cement and lime both are added to sand and water. Hence, it is also called lime-cement mortar. The proportion of cement to lime by volume varies from 1:6 to 1:8. It is strong, economical as compared to both lime and cement mortar.

Special mortars: -

i) fire resistant mortar (by addition of aluminous cement)

ii) light weight mortar: - bulk density $< 15 \text{ kN/m}^3$ (by addition of sawdust, wood powder, asbestos fibers, jute fibers etc. to mortar)

uses of mortar: -

- I. Used to bind bricks, stones in masonry works
- II. To carry out pointing and plaster works
- III. To form joints in pipes
- IV. To improve the appearance of a structure
- V. To fill the cracks in maintenance process

CONCRETE

Concrete is a heterogeneous mixture of coarse aggregates, fine aggregates, binder and water in definite proportions. Sand, gravel and cement are normally used as fine aggregate, coarse aggregate and binder in cement respectively.

Grades of concrete: -

- M20, M25, M30, M35, M40 are different grades of concrete used in construction works.
- Here, letter M refers to mix and the number indicates the compressive strength of concrete at 28 days in N/mm².
- M5 ----- 1:5:10
- M7.5 ----- 1:4:8
- M10 ----- 1:3:6
- M15 ----- 1:2:4
- M20 ----- 1:1.5:3
- M25 ----- 1:1:2

Water cement ratio: -

- It is defined as the ratio of amount of water to amount of cement by mass/weight.
- The strength and quality of concrete primarily depends upon this ratio.
- More the water-cement ratio, less will be the strength of concrete and more will be the workability of concrete.
- For example, 1 bag of cement needs 30litres of water, as 1 liter of water weighs 1 kg, hence

$$\text{Water cement ratio} = \frac{\text{mass of water}}{\text{mass of cement}} = \frac{30 \text{ kg}}{50 \text{ kg}} = 0.60$$

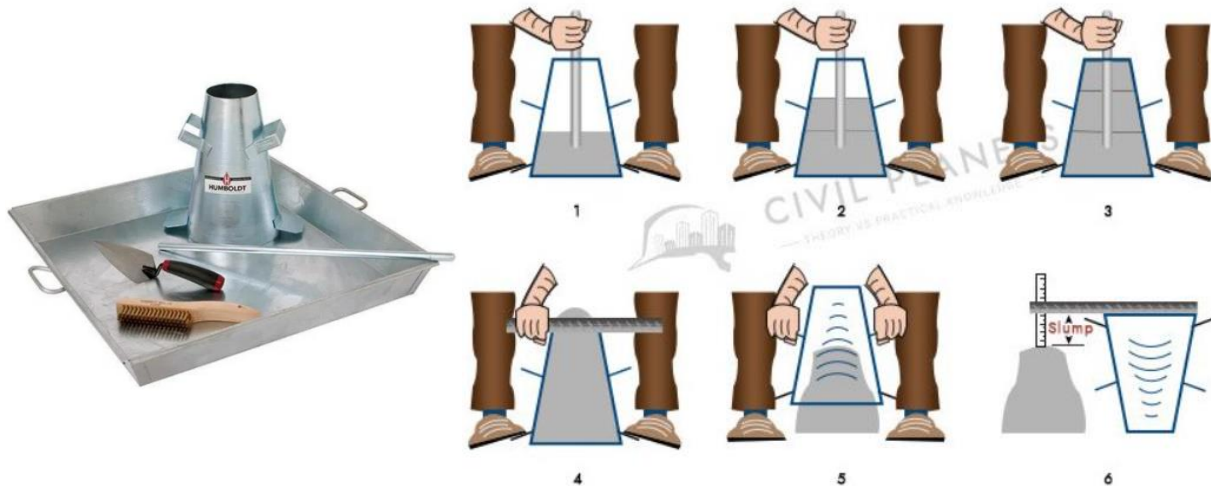
- Normally, the w/c ratio for concrete works is kept between 0.45 to 0.60
- Water in concrete has two following functions,
 - To help in hydration reaction and to make concrete harden thus giving strength to concrete
 - To help in lubricating the aggregates thus making concrete workable

Workability: -

- Workability of concrete is defined as the ease of mixing, transporting, placing and compacting concrete without loss of any homogeneity.
- This is also defined as the amount of internal work needed to produce full compaction.
- It is directly proportional to w/c ratio.
- Slump test is used to measure workability.

CONCRETE

Slump test: -



- This test requires a standard slump cone of top dia. 10cm, bottom dia. 20cm and height 30cm respectively and a tamping rod of dia. 16mm and height 60mm.
- The slump cone is filled up to top in three layers each layer being tamped 25 times with tamping rod and any extra portion from top is struck off.
- Then, the cone is gradually lifted vertically and removed.
- The concrete is allowed to subside and the height of subsidence is measured in mm, which is called slump.
- Different types of slump are discussed below: -
 - True slump – desirable
 - Zero slump – stiff concrete
 - Collapse slump – fresh concrete
 - Shear slump – lack of cohesion



TRUE SLUMP ZERO SLUMP COLLAPSED SLUMP SHEAR SLUMP

Mixing of concrete: -

- The process of rolling, folding and spreading of particles is known as the mixing of concrete.

CONCRETE

- The materials of concrete should be mixed thoroughly so that there is uniform distribution of materials in the mass of concrete and it also ensures cement paste completely covers the surfaces of aggregates.
- The mixing of materials of concrete can be done either with hand or with the help of a cement mixer machine.

Hand mixing: -

- For hand mixing, the materials are stacked on a water-tight platform, which may be either of wood, brick or steel.
- The materials should be thoroughly mixed, at least three times, in dry condition before water is added.
- The prepared mix should be consumed in 30 minutes after adding water.
- The mixing by hand is allowed in case of small works of unimportant works where small quantity of concrete is required.
- For important works, if hand mixing is to be adopted, it is advisable to use 10 percent more cement than specified.

Machine mixing: -

- For machine mixing, all the materials of concrete, including water, are collected in a revolving drum and then the drum is rotated for a certain period. The resulting mix is then taken out of the drum.
- It is found that mixing of concrete materials with the help of machines is more efficient and it produces concrete of better quality in a short time.
- Mixers can be tilting type or non-tilting type. They are generally provided with power-operated loading hoppers.

Tilting drum mixer



Non-tilting drum mixer



- The water should enter the mixer at the same time or before other materials are placed.
- The concrete mixer should be thoroughly washed and cleaned after use.
- The inside portion of the mixer should be inspected carefully at regular intervals. The damaged or broken blades should be replaced.

CONCRETE

- The mixing time should be at least 1 minutes or preferably 2 minutes.
- The concrete discharged by the mixer, after thoroughly mixing concrete materials, should be consumed within 30 minutes.

Transportation and placing of concrete: -

The concrete should be transported in such a way that there will be no segregation. **Segregation** is the phenomenon of separation of ingredients of concrete resulting in a poor and weak mix.

Following precautions should be taken while placing concrete.

1. The formwork or the surface which is to receive the fresh concrete should be properly cleaned, prepared and well-watered.
2. It is desirable to deposit concrete as near as practicable to its final position.
3. The large quantities of concrete should not be deposited at a time. Otherwise the concrete will start to flow along the formwork and consequently the resulting concrete will not have uniform composition.
4. The concrete should be dropped vertically from a reasonable height. For vertical laying of concrete, care should be taken to use stiff mix. Otherwise the **bleeding** of concrete through cracks in forms will take place. The term bleeding is used to mean the diffusion or running of concrete through formwork.
5. The concrete should be deposited in horizontal layers of about 150 mm height. For mass concrete, the layers may be of 400 mm to 500 mm height. The accumulation of excess water in upper layers is known as the laitance and it should be prevented by using shallow layers with stiff mix or by putting dry batches of concrete to absorb the excess water.
6. As far as possible, the concrete should be placed in single thickness. In case of deep sections, the concrete should be placed in successive horizontal layers and proper care should be taken to develop enough bond between successive layers.
7. The concrete should be thoroughly worked around the reinforcement and tapped in such a way that no honeycombed surface appears on removal of the formwork. The term honeycomb is used to mean comb or mass of waxy cells formed by bees in which they store their honey. Hence, if this precaution is not taken, the concrete surface so formed would have a honeycomb like surface.
8. The concrete should be placed on the formwork as soon as possible. But in no case, it should be placed after 30 minutes of its preparation.

CONCRETE

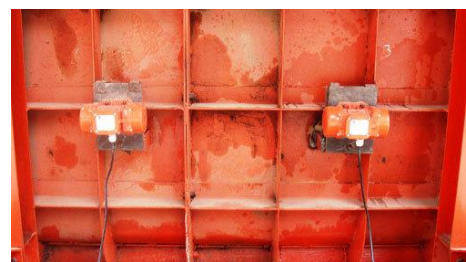
9. During placing, it should be seen that all edges and corners of concrete surface remain unbroken, sharp and straight in line.
10. The placing of concrete should be carried out uninterrupted between predetermined construction joints.

Compaction of concrete: -

- The main aim of compaction of concrete is to eliminate air bubbles/voids by mechanical means thus to give maximum density to concrete.
- It has been observed that presence of 5% of air voids can reduce the strength by 30%.
- Compaction can be either done manually or using mechanical devices/machines.
- Manual compaction: - ramming, tamping and preferred in un-important works.
- Mechanical compaction: - different types of mechanical compaction discussed below.
 - Internal vibrator
 - External vibrator
 - Surface vibrator
 - Table vibrator
 - Plate vibrator
- Internal vibrator: - it is provided with a needle shaft of length 600mm to 2m and dia. of 20mm to 100mm. it is used for the compaction of slab, column and beam. It is also called needle vibrator.



- External vibrator: - it is used where thickness of concrete work is very thin and congestion of reinforcement. These vibrators are fixed on the outer surface of formwork. These are also called shutter vibrators.



- Surface vibrator: - it is mostly used in concrete roads, slabs and concrete floors. It has a footplate through which vibration is given. The concrete depth should not exceed 250mm for using these vibrators.



CONCRETE

➤ Table vibrator: - these are used in laboratories to find the consistency of concrete.

➤ Plate vibrator: - these are mainly used in road work to compact the concrete. The vibration plate beat the concrete surface to compact itself.



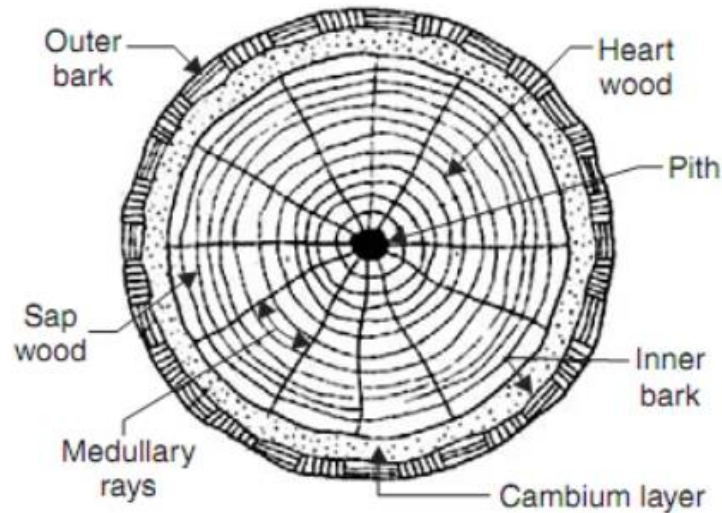
Curing of concrete: -

- Curing of Concrete is a method by which the concrete is protected against loss of moisture required for hydration and kept within the recommended temperature range.
- Curing will increase the strength and durability of structures.
- Curing practice involves keeping the concrete damp or moist until the hydration of concrete is complete and strength is attained.
- Methods of curing: - following methods are used for curing concrete, they are
 - Ponding with water
 - Covering with wet jute bags
 - Covering concrete surface with impermeable membranes like plastic sheets
 - Steam curing – one of the accelerated curing
 - Applying curing compounds

TIMBER

When wood is used for engineering purposes like construction etc. it is called timber. Timber is obtained from trees.

Structure of a tree: -



- Pith: - it is the innermost portion of tree. It is also called medulla or core of tree. It consists of cellular tissues. When plant becomes old, it dies up and decays and the sap is then transferred to woody fibers around the pith.
- Heart wood: - these are the inner annual rings surrounding the pith. It is usually dark in color. It indicates the dead portion of tree as it doesn't take active part in growth of tree but it imparts rigidity to tree. It makes timber strong and durable.
- Sap wood: - these are the outer annual rings between heart wood and cambium layer. It is usually light in color. It indicates recent growth and contains sap. It is also known as alburnum.
- Cambium layer: - it is the thin layer of sap between sap wood and inner bark. It is the sap which is yet to be converted to sap wood.
- Inner bark: - it is the inner layer or skin covering the cambium layer and gives protection to cambium layer.
- Outer bark: - it is the outer skin or cover of tree. It is the outermost protective layer and also known as cortex.
- Medullary rays: - these are the thin radial fibers extending from pith to cambium layer. The function of these rays is to hold the annual rings of heart wood and sap wood.
- Annual rings: - these are the concentric rings added every year. These rings help in predicting the age of tree.

TIMBER

Classification: - trees are divided into two types,

- Exogenous tree
- Endogenous tree

Exogenous tree: - trees which increase in bulk and grow outwards are called exogenous trees. These trees show distinctive annual rings. These are mostly used for engineering purposes. These trees are again subdivided into two parts: -

- Conifers
- Deciduous trees

Conifers: - these trees are evergreen trees. The leaves of these trees never fall until new ones are grown. These trees yield soft woods. These trees have cone-shaped fruits. These are light in color and weight and also weak. These trees show distinct annual rings. Ex: - chir, deodar, fir, pine etc.

Deciduous trees: - these trees shed their leaves in autumn and new ones appear in spring. They yield hard woods. These trees are broad-leaf trees. These are usually dark in color, strong. Durable and mostly used for engineering purposes. These trees don't show distinct annual rings. Ex: - babul, mahogany, sal, teak etc.

Endogenous tree: - trees which grow inwards. These trees have very limited engineering applications. Ex: - bamboo, cane, palm etc.

Seasoning of timber: - the process of reducing moisture content and making timber dry is called seasoning timber. Seasoning also improve other properties of timber, which are listed below.

Advantages of seasoning: -

- Strength
- Hardness
- Durability
- Weight
- Painting and finishing
- Gluing
- Resistance to insect attack
- Electrical resistance
- Heat content

TIMBER

There are two methods of seasoning timber, they are

- Natural seasoning – slow process
- Artificial seasoning – fast process

Natural seasoning: - Seasoning of woods or timbers using natural elements is called natural seasoning. Ex: - water and air seasoning.

Water seasoning: - Removal of wood sap by immersing logs into water flow is called water seasoning. It is carried out on the banks of the river. After that, the logs are allowed to dry. Disadvantage: It is time consuming such as 2 to 4 weeks generally.

Air seasoning: - Exposing the woods to air for seasoning. At first, a platform is required that is built on the ground at 300mm height above the ground. arrangement of woods in layers. Air circulation is maintained between logs because it helps to reduce the moisture which is important for seasoning.

Artificial seasoning: - following are different types of artificial seasoning

- Seasoning by boiling: - boiling wood logs in hot water. Drying is done after proper boiling. It takes a short amount of time. Generally, 3-4 hours is good enough and develops the strength and elasticity. It is not suitable for large amount of timbers.
- Chemical seasoning: - reduction moisture using salt solution is called chemical seasoning. After the absorption of water by the solution logs are let to dry. It increases the strength of the timber and less time-consuming.
- Kiln seasoning: - Seasoning of wood by using a large chamber or oven where there is a good process for the circulation of hot air. It is the Most effective and economic seasoning.

Characteristics of good timber: -

1. HARDNESS

A good quality timber should be hard enough to resist deterioration.

2. STRENGTH

It should have sufficient strength to resist heavy structural loads.

3. TOUGHNESS

It should have enough toughness to resist shocks due to vibrations. It should not break in bending and should resist splitting. Timbers having narrow annual rings, are generally the strongest.

TIMBER

4. ELASTICITY

It should have the property of elasticity so as to regain its original shape after removal of loads. This is a very important property to be considered if the timber is used in making sport goods.

5. DURABILITY

It should be able to resist attacks of fungi and worms and also atmospheric effects for a longer period of time.

6. DEFECTS

Timber should be prepared from the heart of a sound tree and be free from sap, dead knots, shakes and other similar defects.

7. FIBRES AND STRUCTURE

It should have straight and closed fibres and compact medullary rays. It should give a clear ringing sound when struck. Dull heavy sound is an indication of internal decay. Its annual rings should be uniform in shape and colour.

CH 2 PART B: - FOUNDATIONS

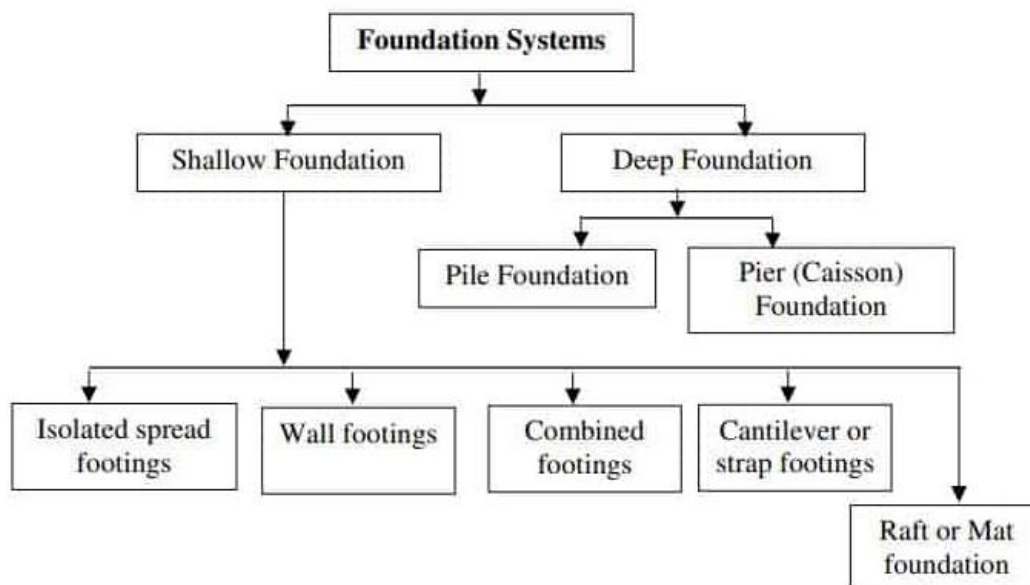
Concept of foundation and its purpose: -

- ✓ The bottom-most artificially built part of a structure which transmits the load of the structure to the ground is called foundation.
- ✓ Foundation of a structure is always constructed below the ground level so as to increase the lateral stability of the structure.
- ✓ It includes the portion of the structure below the ground level and is built, so as to provide a firm and level surface for transmitting the load of the structure on a large area of the soil lying underneath.
- ✓ The solid ground on which the foundation rests is called the Foundation Bed.

Purpose of foundation: -

- ✓ To distribute the load of the structure over a large bearing area so as to bring intensity of loading within the safe bearing capacity of the soil lying underneath.
- ✓ To load the bearing surface at a uniform rate so as to prevent unequal settlement.
- ✓ To prevent the lateral movement of the supporting material.
- ✓ To secure a level and firm bed for building operations.
- ✓ To increase the stability of the structure as a whole.

Type of foundations: -



Shallow foundation: -

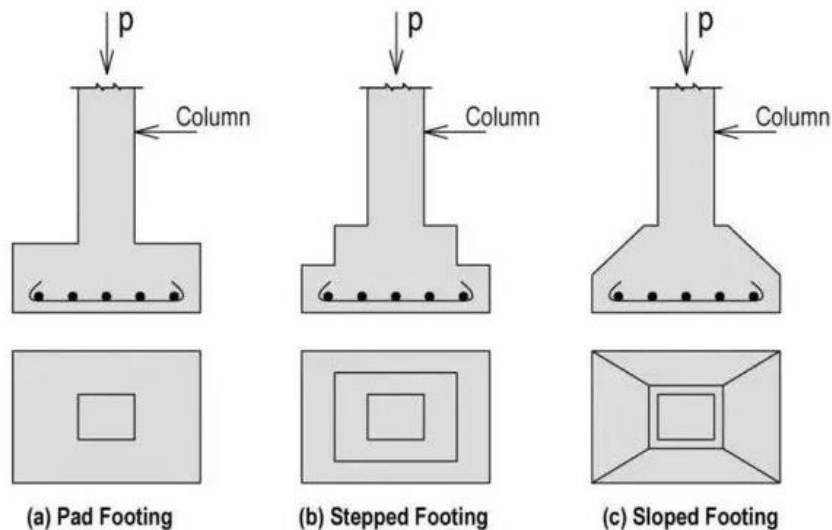
- ✓ When a depth of foundation is less than the width of foundation then it is known as Shallow Foundation. Generally, shallow foundation placed no more than 6 ft depth from the lowest finished floor.

CH 2 PART B: - FOUNDATIONS

- ✓ A shallow foundation is generally used when
 - The sufficient bearing capacity of soil available at shallow
 - Foundation material or strata do not result in undue settlement
- ✓ Footings are the important structural element which transfers the load of column, beam, slab and retaining structures to the soil safely.

Isolated or spread footing: -

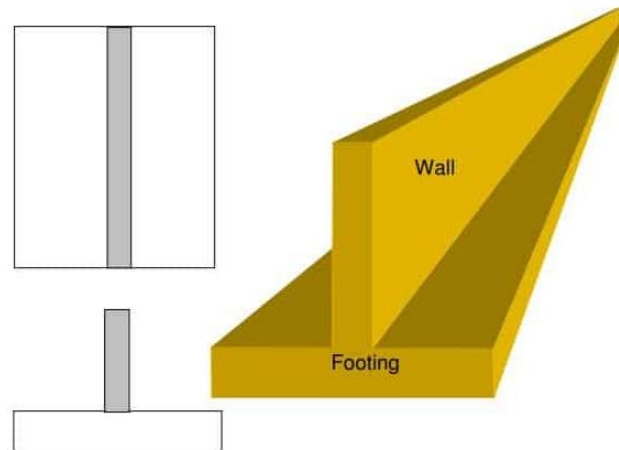
- ✓ It is one of the simplest and worldwide popular types of foundation
- ✓ An isolated footing is mostly used to support a single column
- ✓ This type of foundation suitable when columns are not closely spaced.
- ✓ These are of three types
 - Stepped footing
 - Simple spread footing
 - Sloped footing



Wall footing: -

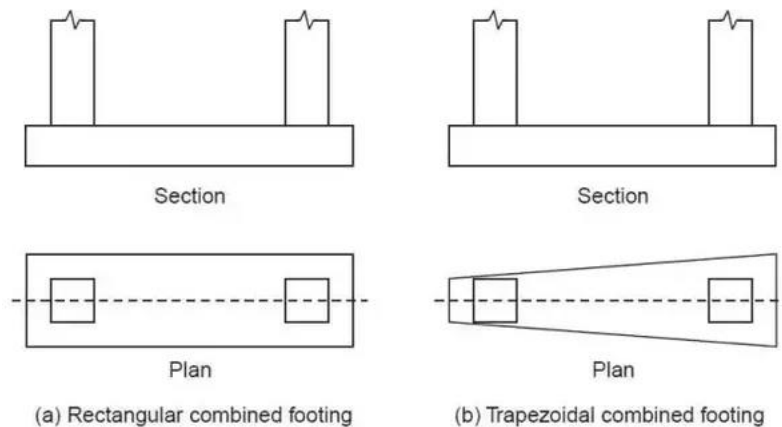
- ✓ These are used to support structural or non-structural walls to transmit and distribute the loads to the soil.
- ✓ Wall footing runs along the direction of the wall.
- ✓ The width of footing is generally kept between 2-3 times the widths of the wall.
- ✓ Wall footing can be constructed from plain concrete, or reinforced concrete stone, brick.
- ✓ It can more effective for load-bearing structure and boundary wall construction.

CH 2 PART B: - FOUNDATIONS



Combined footings: -

- ✓ Combined footings are provided when the column is closely spaced. So that their footing overlap with each other and when soil bearing capacity of a soil is lower this type of footing are used.
- ✓ When columns are closely spaced and if we provide separate isolated footings would overlap, in such case, it is better to provide a combined footing than isolated footing.
- ✓ Other cases where a combined footing is required are: - when the column is located near to property line and sewer line, Dimensions of one side of footing are restricted to due to any reason etc.

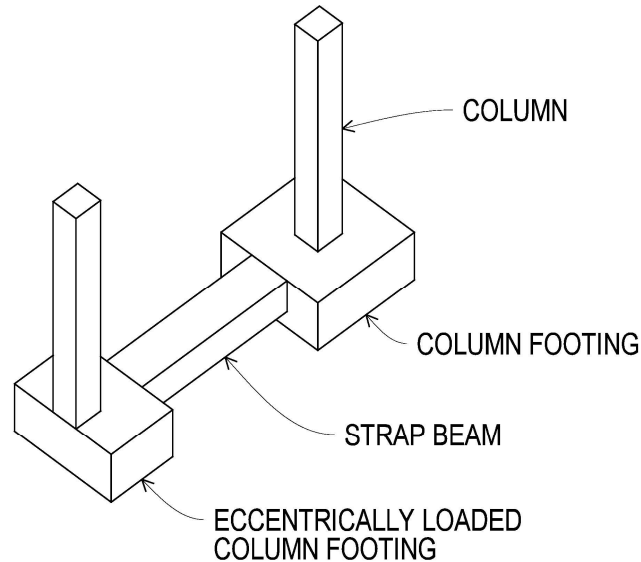


Cantilever or strap footing: -

- ✓ When two or more footing is connected by a beam, it is known as a combined footing, and beam connecting footing are known as a strap.
- ✓ When a square or rectangular footing located near to the property line and if it concentrically located under the column would extend into the adjoining property, which may not be permissible. In such case, strap footing will be a better choice.

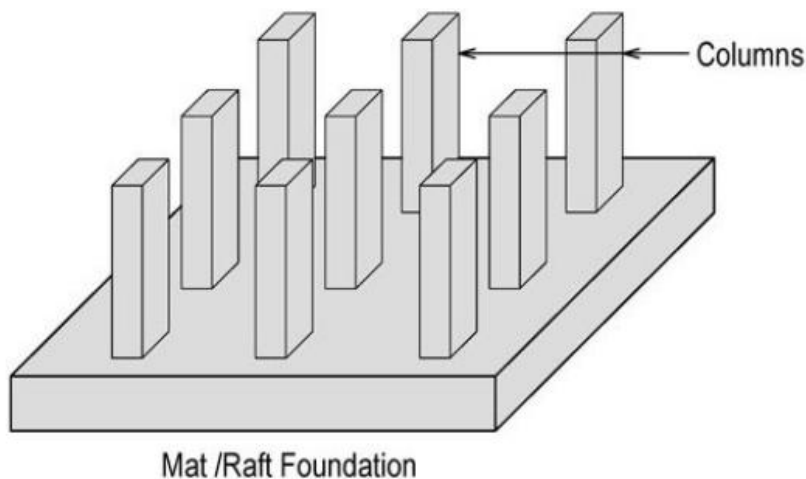
CH 2 PART B: - FOUNDATIONS

- ✓ The strap beam provided to connect two spread footing columns does not remain in contact with soil and thus does not transfer any pressure to the soil.
- ✓ The main function of the strap beam is to transfer a load of the heavily loaded outer column to the inner one



Raft or mat foundation: -

- ✓ A raft foundation, also called a mat foundation, is essentially a continuous slab resting on the soil that extends over the entire footprint of the building, thereby supporting the building and transferring its weight to the ground.
- ✓ A Raft foundation also used for low bearing capacity soil, as it distributes the weight of the building over the entire area of the building, and not over the smaller zone or at the individual point.
- ✓ It is recommended when compressed soil such as clay exists.



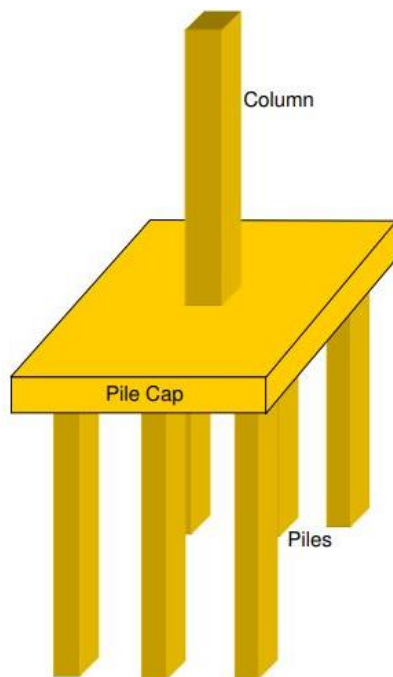
CH 2 PART B: - FOUNDATIONS

Deep foundations: -

- ✓ A foundation in which the depth of foundation is more than the width of the foundation is known as a deep foundation.
- ✓ Following are the different types of deep foundations.

Pile foundation: -

- ✓ The pile is a type of deep foundation is made of concrete, timber, or steel. It is like a small-diameter column which is driven into or cast in the ground.
- ✓ This types of foundation primly used in bridge construction.
- ✓ This types of the foundation are used when the soil below the foundation not having sufficient bearing capacity to carry the load of building into deep soil up to hard strata.
- ✓ The major function of the pile foundation is to transmit loads to the lower level of the ground by the combination of friction pile and end-bearing pile at the pile point or base.

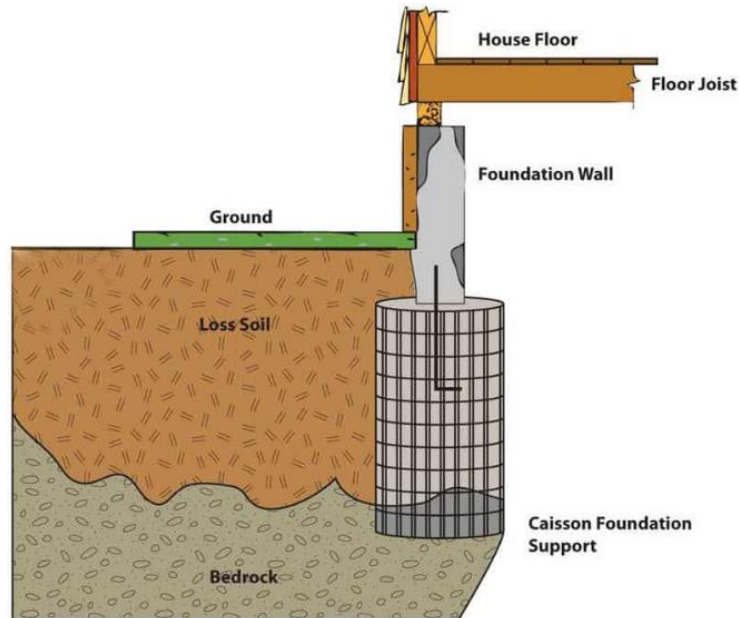


Pier/caisson foundation: ó

- ✓ A Caisson is one type of watertight retaining structure used in the construction of a concrete dam, as pier of bridge construction in the river or for the repair of ships.
- ✓ Caisson is prefabricated hollow box or cylinder sunk into the water or ground to some desired depth and then filled with concrete thus forming a foundation.

CH 2 PART B: - FOUNDATIONS

- ✓ Caisson Types of foundation is majorly used for bridge construction & other structures that require foundation beneath rivers & other bodies of water because caisson can be transported by floating to the construction site and sunk in water to use as a pier of foundation.
- ✓ Caisson foundation used, when the soil of adequate bearing strength is found below surface layers of weak materials such as fill or peat.



Assignment: - classification of piles according to materials, function and method of installation

Building and its classification: -

- ✓ Building is defined as a structure which is a relatively permanent enclosed construction over a plot of land, having a roof and usually windows and often more than one level, used for any of a wide variety of activities, as living, entertaining, or manufacturing.
- ✓ Buildings are classified in to following categories based on occupancy, they are: -
 - Residential Building
 - Educational Building
 - Office Building
 - Historical Building
 - Industrial Building
 - Recreational Building
 - Institutional Building
 - Commercial Building
 - Hazardous Building
 - Storage Building
 - Assembly Building
 - Public Building

Residential Building: -

The buildings in which an individual or a family or a group of families reside temporarily or permanently are referred as residential buildings such as flat, cottage, house, bungalow, etc.

Educational Building: -

The buildings in which education is imparted to the children are referred as Educational Buildings such as school, college, library, coaching center, etc.

Office Building: -

The buildings which are used for official purposes by any department such as Income Tax, Telegraph, Telephone, Public health referred as Office Buildings.

Historical Building:-

The buildings which indicate the historic importance are referred as Historical Buildings such as Lal Quila, Taj Mahal, Jama Masjid, Qutub Minar, etc.

Industrial Building: -

The Buildings used for producing industrial goods or products are referred as Industrial Buildings such as factories, workshops, etc.

PART-B CH 1: - INTRODUCTION

Recreational Building: -

The buildings used for recreation purposes are referred as Recreational Buildings such as cinemas, clubs, swimming, pools, etc.

Institutional Building: -

The buildings constructed for the care of persons suffering from various diseases mental as well as physical are referred as Institutional Buildings such as hospitals, sanatoria, jails, prisons etc.

Commercial Building: -

The buildings used for business purposes referred as Commercial Buildings such as shops, stores, banks etc.

Storage Building: -

The buildings used for the storage of various products are referred as storage buildings such as cold storages, godowns etc.

Hazardous Building: -

The buildings used for the purposes of storage and handling of highly combustible materials are referred as Hazardous Buildings such as Building used for the storage of sulphur dioxide, ammonia, carbon dioxide etc.

Assembly Building: -

The buildings used for get together purposes are referred as Assembly Buildings such as Temples, town halls mosque, etc.

Public Building: -

The buildings constructed in the interest of the public are referred as Public Buildings such as railway station, bus stands, airport etc.

Different components of a building: -

Broadly, any building components can be categorized into two parts, they are:-

- ✓ Substructure
- ✓ Superstructure

Substructure: -

It is the portion of a building situated underneath the ground. It is also called foundation.

Superstructure: -

The portion of a building situated above the ground level is called superstructure.

PART-B CH 1: - INTRODUCTION

The components of a building are further classified as follows: -

Foundation: -

- ✓ It is the lowest part of a building/structure which transfers all the loads (dead load, live load etc.) coming from the super structure to the soil below.
- ✓ It forms the major part of a structure. Stronger the foundation, more stable the structure will be.

Plinth: -

The portion of a building lying between the surrounding ground and the top floor just above the ground is called plinth. It is provided to prevent the surface water from entering into the building.

DPC: -

DPC or damp proof course is a layer of water proofing materials like asphalt, bitumen, water proof cement provided on the plinth on which the walls are constructed.

Walls: -

Walls are the vertical members on which the roof rests. Walls are provided to divide the floor space into rooms and in the desired pattern. Walls also provide privacy, security and protection from sun, wind, rain etc.

Column: -

These are the isolated load bearing member which carry the axial compressive load of as structure.

Floors: -

Floors can be defined as flat supporting elements dividing a building into different levels i.e. first floor, second floor etc. to create more accommodation on a given land. They provide a firm and dry platform for people and other furniture, equipments etc.

Doors, windows and ventilation: -

Doors are provided as a barrier secured in an opening left in a wall to access the building, room or passage.

A window may be defined as an opening left in wall for the purpose of providing daylight, vision, natural air and ventilation.

Stairs: -

Stairs can be defined as a structure comprising of number of steps arranged in series connecting one floor to another. Stairs are also used to access various floors of the building.

PART-B CH 1: - INTRODUCTION

Roof: -

A roof is the topmost part of a building which covers the space below and protects from rain, direct sunlight, snow, wind etc.

Building finishes: -

These include items like plastering, pointing, white and colour washing, varnishing, painting, distempering etc.

Building services: -

These include services like water supply, drainage, electricity, acoustics, heating, air conditioning, fire detection and control etc.

Site investigation – objectives, site reconnaissance and explorations: -

Site investigation refers to the procedure of determining surface and subsurface condition in the area of proposed construction. The purpose of site investigation is to get clear information about the soil and hydrological conditions at the site.

Objectives of Site Investigation: -

- ✓ To access the general suitability of the site
- ✓ To achieve safe and economical design of foundations and temporary works.
- ✓ To know the nature of each stratum and engineering properties of the soil and rock, which may affect the design and mode of construction of proposed structure and foundation?
- ✓ To foresee and provide against difficulties that may arise during construction due to ground and other local conditions.
- ✓ To find out the sources of construction material and selection of sites for disposal of water or surplus material.
- ✓ To investigate the occurrence or causes of all natural and manmade changes in conditions and the results arising from such changes.
- ✓ To ensure the safety of surrounding existing structures.
- ✓ To design for the failed structures or remedial measures for the structures deemed to be unsafe.
- ✓ To locate the ground water level and possible corrosive effect of soil and water on foundation material.

Site reconnaissance: -

- ✓ It is the first stage of site investigation. In this stage, visual inspection of the site is done and information about topographical and geological features of the site is collected. The general observations made during reconnaissance survey are as follows: -

PART-B CH 1: - INTRODUCTION

- Presence of drainage ditches and dumping yards etc.
- Location of groundwater table by observing well in that site
- Presence of swamps springs etc.
- High flood level marks on the bridges, high rise buildings, etc.
- Past record of landslides, floods, earthquakes in that region
- Study of aerial photographs of the site, blueprints of present buildings. Geological maps etc.
- Observation of deep cuts to know about stratification of soil
- Observation of settlement cracks of existing structures

Site exploration: -

It is divided into two steps. They are: -

- ✓ Preliminary site exploration
- ✓ Detailed site exploration

Preliminary site exploration: -

- ✓ It is carried for small projects, light structures. Highways etc.
- ✓ The main objective is to obtain an approximate picture of sub-soil conditions at low cost
- ✓ It is also called general site exploration
- ✓ The soil sample is collected from experimental borings and shallow test pits and laboratory tests are conducted.
- ✓ Following observations are generally done during preliminary site exploration
 - depth and extent of soil strata
 - soil composition
 - moisture content of soil
 - engineering properties of soil
 - depth of hard stratum from ground level

Detailed site exploration: ó

- ✓ It is preferred for complex projects, major engineering works, heavy structures like dams, bridges etc.
- ✓ A huge amount of capital is required for detailed site exploration
- ✓ In this stage, a numerous field tests like vane shear strength, plate load test and lab tests like permeability test etc. Are conducted on undisturbed soil samples.
- ✓ Finally, the detailed soil exploration reports are prepared.

UNIT – V

BRICK AND STONE MASONRY**5.1. Brick masonry**

5.1.1. Definition of terms

1. **Stretcher:** This is a brick laid with its length parallel to the face or front or direction of a wall. The course containing stretchers is called a stretcher course. See fig 5.1.

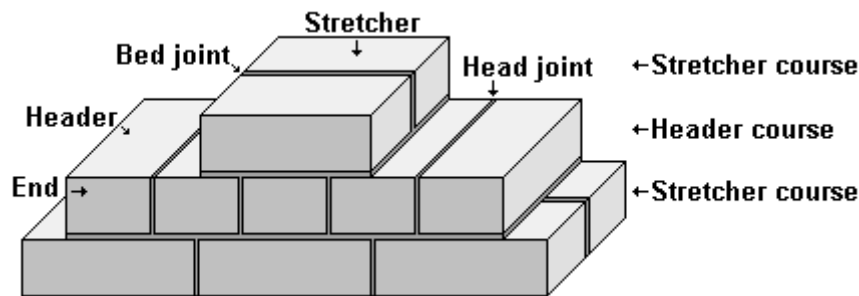


Fig.5.1. Definitions

2. **Header:** This is a brick laid with its breadth or width parallel to the face or front or direction of a wall. The course containing headers is called a header course. See fig.5.1.
3. **Arrises:** the edges formed the intersection of plane surfaces of brick are and they should be sharp, square and free from damage. See fig. 5.1.
4. **Bed:** the lower surface of the brick when laid flat is known as the bed.
5. **Bed joint:** The horizontal layer of mortar upon which the bricks are laid is known as a bed joint. See fig. 5.1.
6. **Perpends:** The vertical joints separating the bricks in either length or cross directions are known as the perpends and for a good bond, the perpends in alternate courses should be vertically one above the other. See fig. 5.1.
7. **Lap:** The horizontal distance between the vertical joints in successive courses is termed as a lap and for a good bond, it should be one-fourth of the length of a brick. See fig. 5.1.
8. **Closer:** A piece of brick which is used to close up the bond at the end of brick courses is known as a closer and it helps in preventing the joints of successive courses to come in a vertical line. Generally the closer is not specially moulded. But it is prepared by the mason with the edge of the trowel. Following are the types of closers.
 - (i) Queen closer (fig. 5.2): This is obtained by cutting the brick longitudinally in two equal parts. It can also be made from two quarter bricks, known as the quarter closers, to minimize the wastage of bricks. A queen closer is generally placed near the quoin header to obtain the necessary lap.

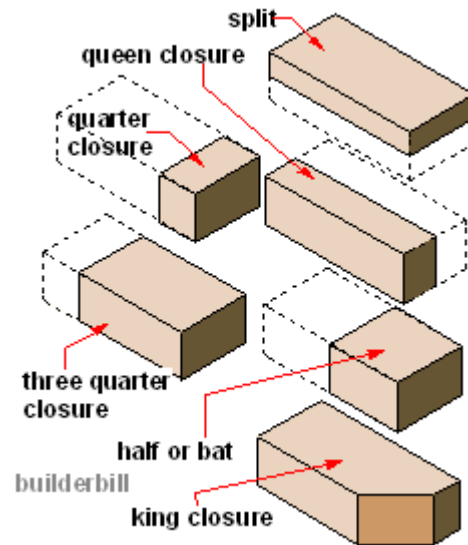


Fig.5.2. Closures

- (ii) King closer (fig. 5.2): This is obtained by cutting a triangular portion of the brick such that half a header and half a stretcher are obtained on the adjoining cut faces. A king closer is used near door and window openings to get satisfactory arrangement of the mortar joints.
- (iii) Bevelled closer (fig. 5.3): This is obtained by cutting a triangular portion of half the width but of full length. A bevelled closer appears as a closer on one face and as a header at the other face. It is used for the splayed brickwork.

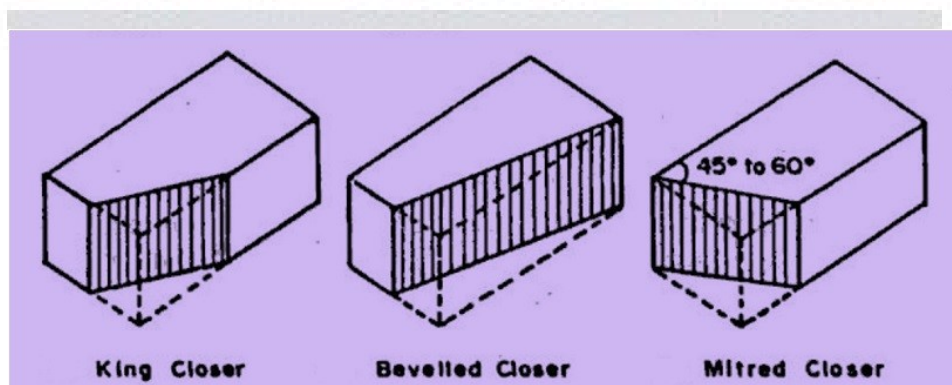


Fig.5.3. Closure

- (iv) Mitred closer (fig. 5.3): This is obtained by cutting a triangular portion of the brick through its width and making an angle of 45 to 60 with the length of the brick. It is used at corners, junctions, etc.

9. Bat: This is a piece of brick, usually considered in relation to the length of a brick and accordingly known as half bat or three-quarter bat. A bevelled bat may be formed as shown in fig 5.4.

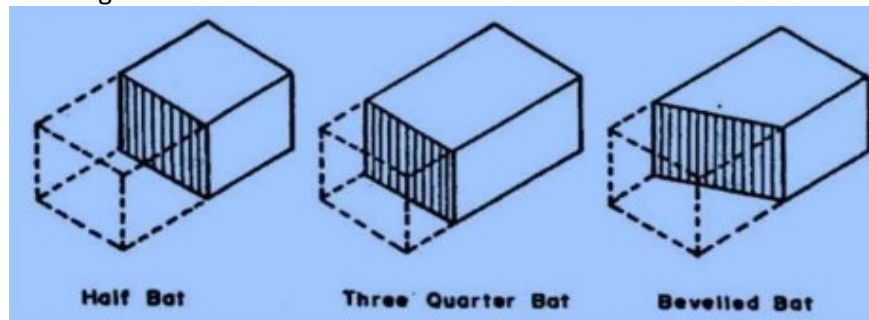


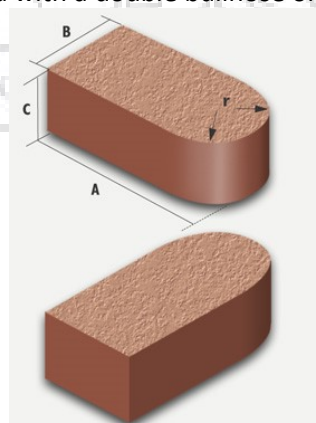
Fig.5.4. Brick bat

10. Bullnose: A brick moulded with a rounded angle is termed as a bullnose and it is used for a rounded quoin. A connection which is formed when a wall takes a turn is known as a quoin. The centre of the curved portion is situated on the long centre-line of the brick. Fig. 5.5 shows a bullnose brick.

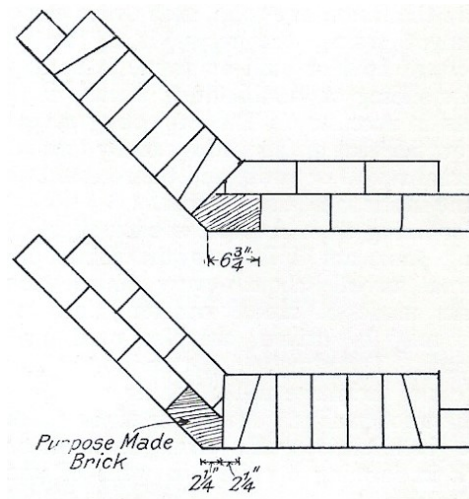


Fig.5.5. Bull nose

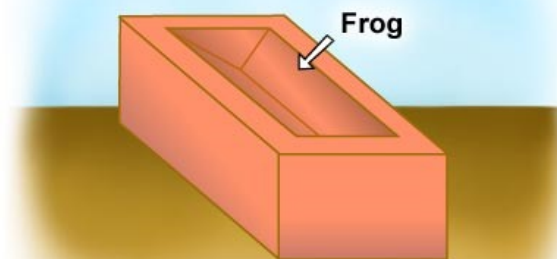
11. Cownose: A brick moulded with a double bullnose on end is termed as a cownose.



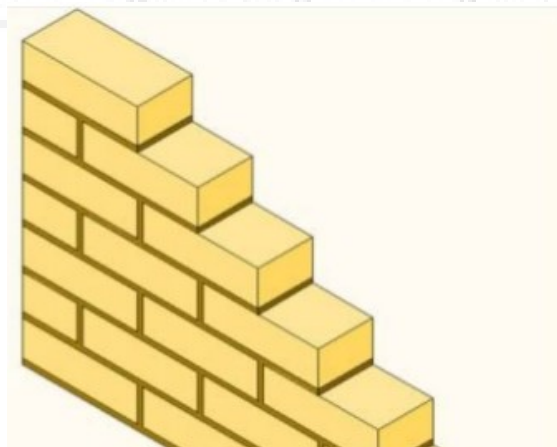
12. Squint quoin: A brick which is cut or moulded such that an angle other than a right angle is formed in plan is known as a squint quoin.



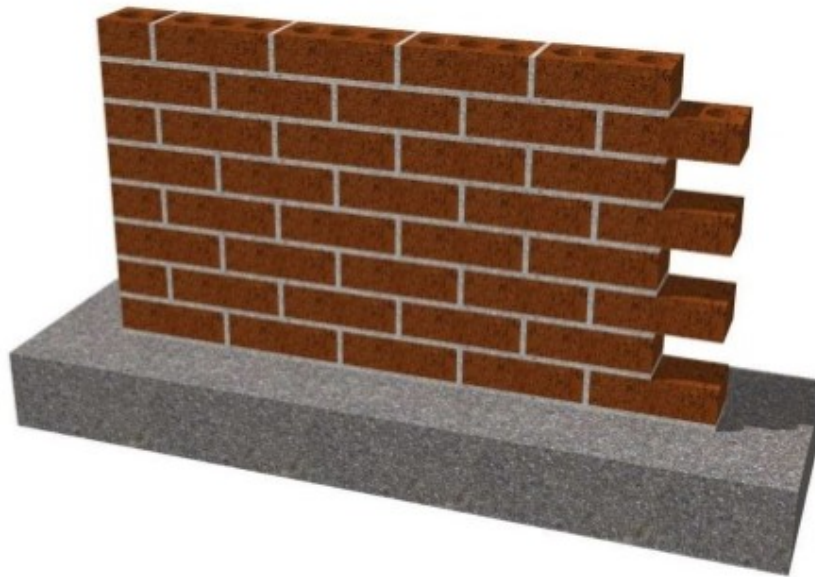
13. Frog: A frog is a mark of depth about 10 mm to 20 mm which is placed on the face of a brick to form a key for holding the mortar. The wire cut bricks are not provided with frogs. A pressed brick as a rule has frogs on both the faces. A hand-made brick has only one frog.



14. Racking back: The termination of a wall in a stepped fashion is known as the racking back.



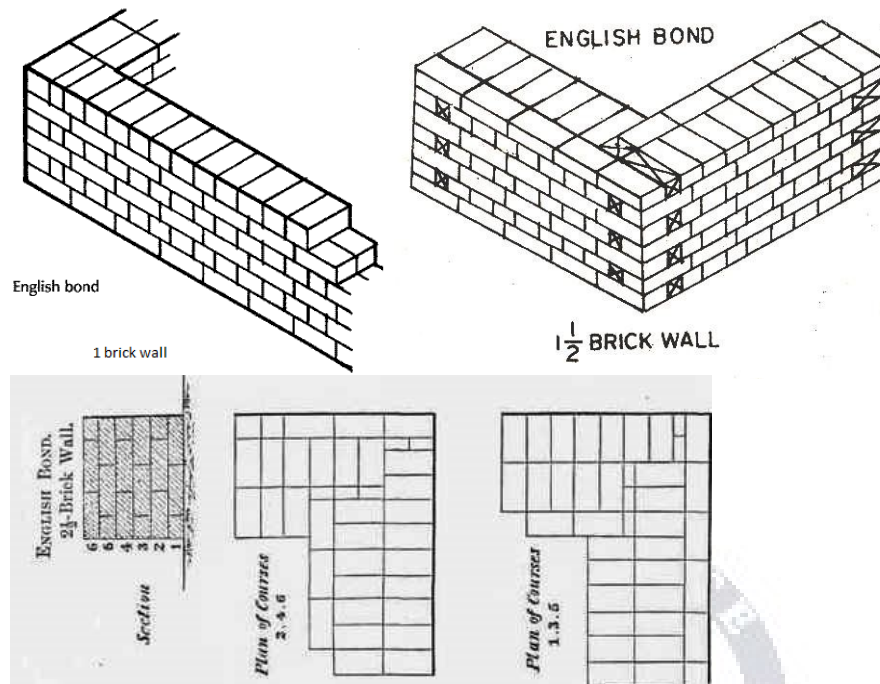
15. Tothing: The termination of a wall in such a fashion that each alternate course at the end projects is known as the tothing and it is adopted to provide adequate bond, when the wall is continued horizontally at a later stage.



5.1.2. English bond

This type of bond is generally used in practice. It is considered as the strongest bond in brickwork. Following are the features of an English bond:

- i. The alternate courses consist of stretchers and headers.
- ii. The queen closer is put next to the quoin header to develop the face lap.
- iii. Each alternate header is centrally supported over a stretcher.
- iv. If the wall thickness is an even multiple of half-brick, the same course shows headers or stretchers in both the front and the back elevations. But if the wall thickness is an uneven multiple of half-brick, a course showing stretcher on the face shows header on the back and vice versa.
- v. The bricks in the same course do not break joints with each other. The joints are straight.
- vi. In this bond, the continuous vertical joints are not formed except at certain stopped ends.
- vii. The number of mortar joints in the header course is nearly double than that in the stretcher course. Hence care should be taken to make the header joints thinner; otherwise the face lap disappears quickly.
- viii. A header course should never start with a queen closer as it is liable to get displaced in this position.
- ix. The queen closers are not required in the stretcher courses.
- x. In the stretcher course, the stretchers have a minimum lap of one-fourth of their length over the headers.
- xi. For walls having thickness of two bricks or more, the bricks are laid as stretchers or headers only on the face courses of the wall. The interior filling is done entirely with the headers.



5.1.3. Flemish bond

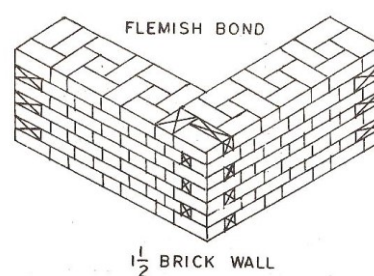
Flemish bond: In this type of bond, the headers are distributed evenly and hence, it creates a better appearance than the English bond.

Following are the peculiarities of a Flemish bond:

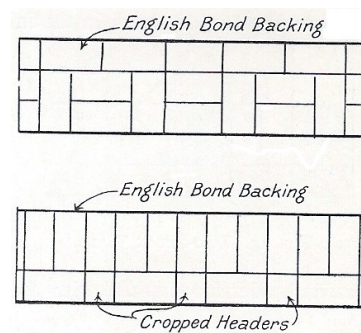
- (i) In every course, the headers and stretchers are placed alternatively.
- (ii) The queen closer is put next to the quoin header in alternate courses to develop the face lap.
- (iii) Every header is centrally supported over a stretcher below it.
- (iv) The Flemish bond may be divided into two groups:
 - a. Double Flemish bond
 - b. Single Flemish bond

In double Flemish bond, the headers and stretchers are placed alternatively in front as well as the back elevations.

For this type of bond, the half bats and three-quarter bats will have to be used for walls having thickness equal to odd number of half bricks. For walls of thickness equal to even number of half bricks, no bats will be required and a stretcher or a header will come out as a stretcher or a header in the same course in front as well as back elevations. This bond gives better appearance than the English bond. But it is not as strong as the English bond as it contains more number of stretchers.



In Single Flemish bond, the face elevation is of Flemish bond and the filling as well as backing are of the English bond. Thus, in this type of bond, an attempt is made to combine the strength of the English bond with the appearance of the Flemish bond. This type of bond is used when expensive bricks are used for the face work. But in order to construct this bond, a wall of minimum thickness $1\frac{1}{2}$ bricks is required.



- (v) The bricks in the same course do not break joints With each other. The joints are straight.
- (vi) In this bond, the short continuous vertical joints are formed
- (vii) The brickbats are to be used for walls having a thickness equal to uneven number of half-brick.

5.2. Reinforced brick masonry

Meaning or the term; when strength is the main criterion in the design of a brick wall, it is desirable and economical to incorporate reinforcement of steel or iron in the body of the brickwork. This is termed as the reinforced brickwork and it is adopted under the following circumstances:

- (i) When the brickwork has to resist tensile and shear stresses, the reinforced brickwork is used.
- (ii) In order to prevent the dislocation of brickwork for Structures constructed on soils of unequal bearing capacity, the reinforced brickwork is adopted.
- (iii) The reinforced brickwork becomes helpful for constructing brickwork which has to work as a beam over an opening.
- (iv) For constructing retaining walls in brickwork for floor slabs of short span, the reinforced brickwork can be used effectively.
- (v) When it is- desired to increase the longitudinal bond, the reinforced brickwork can be used successfully.
- (vi) When the brick wall is likely to be subjected to heavy compressive loads, the reinforced brickwork can be adopted.
- (vii) The reinforced brickwork can also resist lateral loads and hence it can be used in seismic areas also.

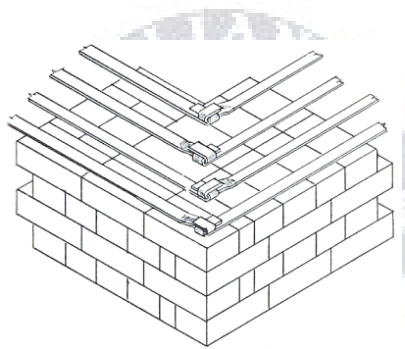
The reinforced brickwork uses first class bricks having high compressive strength. For embedding the reinforcement, the dense cement mortar is used. The reinforcing material may be in the form of hoop-iron, mild steel bars, mild steel flats or expanded mesh. The reinforcement may be placed either horizontally or vertically.

The advantages claimed by this type of construction are manifold. It is cheap, durable, fire-proof, easy to construct and in most of the cases, it results in the increase of floor space due to adoption of the brickwork of less thickness.

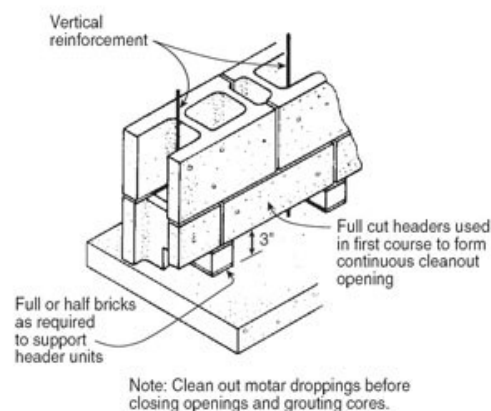
Typical cases: The applications of reinforced brickwork for some of the typical structures are briefly discussed below.

- (i) Walls: The reinforcement in walls is in the form of iron bars or expanded metal mesh. The various types of patented expanded metal mesh in suitable sizes are available in the market. The reinforcement is generally provided at every third or fourth course. The steel fabric is spread flat on the cement mortar and pressed evenly. The next course of brickwork is then started.

The hoop-iron may be used as reinforcement for walls. This is in the form of flat bars of section about 25 mm x 2 mm. They are hooked at corners and junctions as shown in fig. below. They are usually dipped in tar and sanded immediately so as to increase their resistance against rusting. The provision usually made is one strip every thickness of half-brick.



The reinforcement in vertical direction may be provided by using special bricks as shown in fig. below. The vertical round bars of steel are then placed in the holes and this vertical reinforcement is anchored by wires at suitable intervals.



The mild steel circular bars of small diameter, say about 6 mm, can also be effectively used as longitudinal reinforcement in the walls below

- (ii) Piers: Generally the isolated brick piers are strengthened by reinforcement. A one-brick pier with reinforcement is shown in fig. Below. The steel plates are provided at every fourth course and the steel bars are anchored in the foundation concrete.



- (iii) Lintels: The reinforcement, in case of brick lintels, consists of steel bars of 6 mm to 12 mm diameters. The bricks are arranged in such a way that bricks 20 mm to 30mm wide space is left lengthwise between adjacent bricks for the insertion of reinforcement. The gap or joint is filled with cement mortar of proportion 1:3. The main reinforcement is provided at the bottom of the lintel. If necessary, the stirrups of 6 mm diameter, are provided at every third vertical joint.
- (iv) Slabs: It is possible to construct floor slabs of brickwork with reinforcement as shown in fig. below. The method of construction is as follows:
- The centering is done at proper level. It is generally in the form of a platform of wooden planks, supported on beams.
 - The centering is covered with earth for a depth of about 20 mm to 25 mm, The earth is well beaten and fine sand is sprinkled over it.
 - The reinforcement, as required, is placed in position.
 - The thickness of slab is kept in relation to brick dimensions and accordingly the bricks are laid in one or two courses.
 - The joints are filled with mortar. It should be seen that the reinforcement is completely embedded in mortar.
 - The work is kept moist for a period of two days and then it is kept fully wet for a fortnight or so.
 - The centering is removed.
 - The top and bottom surfaces of slab are then suitably finished



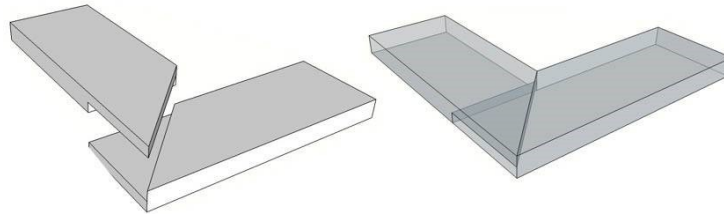
5.3. Stone masonry

Joints in stone masonry:

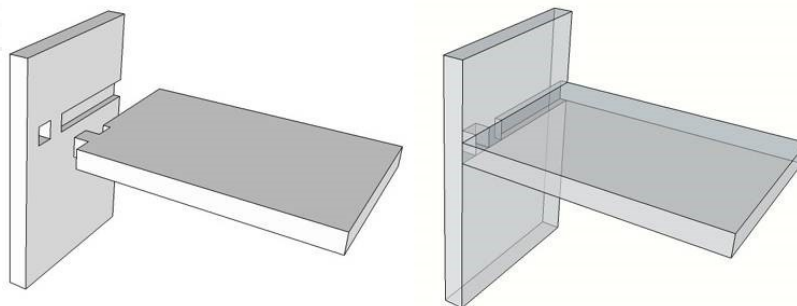
- (i) **Butt of square joint:** In this type of joint, the square surface of one stone is placed against that of another as shown in the fig below. This is the most common joint and is extensively used for ordinary work.



- (ii) **Rebated or lapped Joint:** In this type of joint, the rebates provided which prevent the movements of stones. The two such forms of rebates are shown in figures below. The length of the rebate depends on the nature of the work. But it should not be less than 70 mm. This joint is used for arch work, coping on gables, etc.



- (iii) **Tongued and grooved joint:** In this type of joint, a projection is kept on one stone and a corresponding sinking is provided in the other stone as shown in fig. below. This arrangement prevents the sliding of one stone over the other. This joint is also known as a joggle joint and is rarely used as it involves a great deal of labour and thus becomes expensive. For the end portions of ashlar masonry, the mortar joggled joints are sometimes provided. The cement grout is poured in the joggles formed by means of a hammer and a punch.



- (iv) **Tabled Joint:** In this type of joint, a joggle is formed in the bed of the stone to prevent lateral movement. See fig. below. The depth of projection is about 40 mm and the width of Projection is about one-third the breadth of the stone. This type of joint is used in case of structures such as sea-walls where the lateral pressure is heavy.

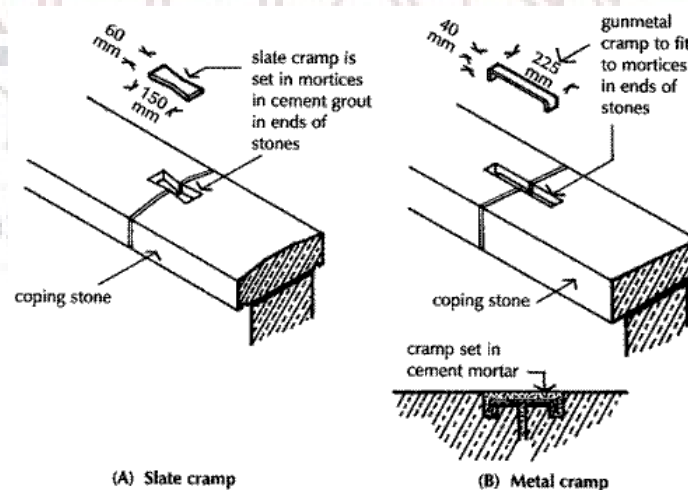
- (v) **Saddled or water Joint:** This type of joint is provided to protect the joints of the cornices and such other weathered surfaces.

With the help of this arrangement, any water moving on the weathered surface is diverted from the joints. The saddle is generally bevelled backwards from the front edge so as to make it inconspicuous.

- (vi) **Rusticated joint:** sometimes the margins or edges of stones used for plinth, quoin, outer walls of lower stories, etc., are sunk below the general level. The term rusticated is used to indicate such masonry.
- (vii) **Plugged Joint:** In this type of joint, the dovetail shaped mortices are provided in the sides of adjacent stones as shown in fig. below. When stones are placed in position, the molten lead is poured in the joint, which, when cooled, connects the stones firmly. The cement grout is sometimes used in place of the molten lead. This joint is used for copings, cornices, etc.
- (viii) **Dowelled Joint:** In this type of joint, a hole is cut into each stone and loose dowels, which are small pieces of hard stone, slate, gunmetal, brass, bronze or copper, are inserted and secured with the cement. The dowelled joint can be easily used in place of joggled joints.

The dowelled joint, when adopted for columns, is known as a bed plug. The dowel are generally 25mm thick and 100mm to 150mm long. This joint also ensures stability of the stones against the displacement

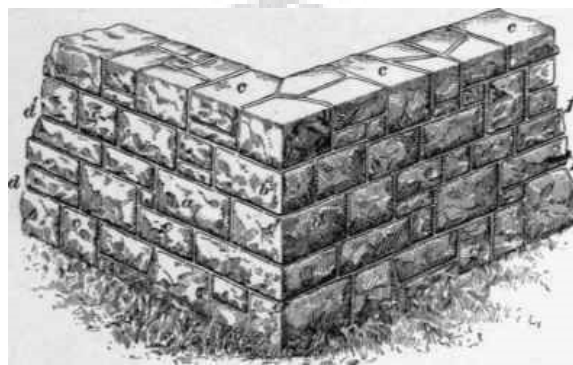
- (ix) **Cramped joint:** In this type of joints, the cramps are used instead of dowels. The cramps are the pieces of non – corrosive metals such as gunmetal, copper, etc. and their ends are turned down to a depth of about 40 mm to 50 mm. The length, width and thickness of the cramps vary from 200 mm to 300 mm, 25 mm to 50 mm and 5 mm to 10 mm respectively. The holes made on the stones should be of dovetail shape as shown in fig. below.



Rubble stone masonry:

1. Coursed rubble masonry: In this type of rubble masonry, the heights of stones vary from 50 mm to 200 mm. The stones are sorted out before the work commences. The masonry work is then carried out in courses such that the stones in a particular course are of equal heights. This type of masonry is used for the construction of public buildings, residential buildings, etc. The coursed rubble masonry is further divided into three categories.

- (i) Coursed rubble masonry I sort: in this type, the stones of the same heights are used and the courses are also of the same heights. The face stones are dressed by means of a hammer and the bushings do not project by more than 40 mm. The thickness of mortar joint does not exceed 10 mm.



- (ii) Coursed rubble masonry II sort: This type is similar to I sort except the following:
- The stones to be used are of different heights
 - The courses need not be of equal heights
 - Only two stones are to be used to make up the height of one course.
 - The thickness of the mortar joints is 12 mm.

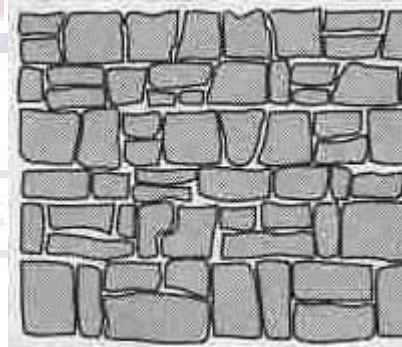


- (iii) Coursed rubble masonry III sort: This type is similar to I sort except the following:
- The stones to be used are of different heights, the minimum being 50 mm.
 - The courses need not be of equal heights
 - Only three stones are to be used to make up the height of one course.

- d. The thickness of the mortar joints is 16 mm.



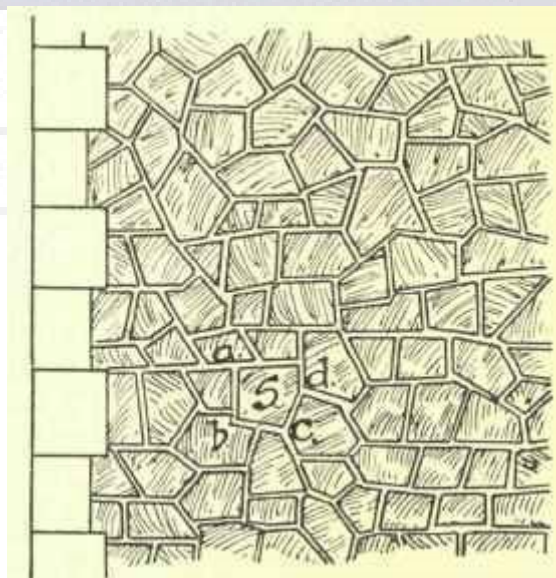
2. **Uncoursed rubble masonry:** In this type of rubble masonry, the stones are not dressed. But they are used as they are available from the quarry, except knocking out some corners. The courses are not maintained regularly. The larger stones are laid first and the spaces between them are then filled up by means of spalls or snecks as shown in fig. below. The wall is brought to a level every 300 mm to 500 mm. This type of rubble masonry, being cheaper, is used for the construction of compound walls, godowns, garages, labour quarters, etc.



3. **Random rubble masonry:** In this type of rubble masonry, the stones of irregular sizes and shapes are used as in fig. below. The stones are arranged so as to have a good appearance. It is to be noted that more skill is required to make masonry structurally stable. If the face stones are chisel-dressed and the thickness of mortar joints does not exceed 6 mm, it is known as the random rubble masonry I sort. If the face stones are hammer-dressed and the thickness of mortar joints does not exceed 12 mm, it is known as the random rubble masonry II sort. This type of masonry is used for the construction of residential buildings, compound walls, godowns, etc.



4. **Dry rubble masonry:** This is just similar in construction to the coursed rubble masonry Ill sort except that no mortar is used in the joints. This type of construction is the cheapest, but it requires more skill in construction. It is extensively used for compound walls, pitching on bridge approaches, retaining walls, etc In order to prevent the displacement of stones and to make work more stable, the two courses at top and about 500 length at the ends are sometimes built in mortar.
5. **Polygonal rubble masonry:** In this type of rubble masonry, the stones are hammer dressed and the stones selected for face work are dressed in an irregular polygonal shape. Thus the face joints are seen running in an irregular fashion in all directions. It is to be noted that more skill is required in the construction of this Polygonal rubble masonry type of masonry. As the stones are of irregular shape, it is difficult to adjust them with regard to stability and appearance of the work as a whole.



6. **Flint rubble masonry:** In this type of rubble masonry, the stones used are flints which are irregularly shaped nodules of silica. The width and thickness vary from 80 mm to 150 mm and the length varies from 150 mm to 300 mm. The

stones are extremely hard. But they are brittle and therefore they break easily. The face arrangement may be either coursed or uncoursed. The strength of a flint wall is increased by introducing lacing courses of either thin long stones or bricks or tiles at vertical distances of Flint rubble masonry one to two metres. This type of masonry is used at places where the flints are available readily and economically.

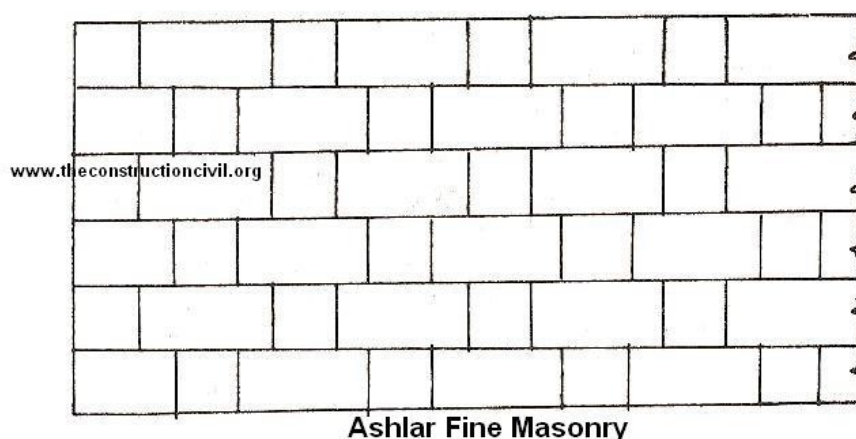


Ashlar masonry:

In this type of construction, the square or rectangular blocks of stones are used. The courses are not necessarily of the same height. The height of stones varies from 250 mm to 300 mm. The length of stones should not exceed three times the height and the depth into the wall should be to at least equal to half the height.

Following are the different types of ashlar masonry:

1. **Ashlar fine masonry:** In this type of ashlar masonry, the beds, sides and faces are finely chisel-dressed. The stones are arranged in proper bond and the thickness of the mortar does not exceed 3 mm. This type of construction gives perfectly smooth appearance but it is costly in construction.

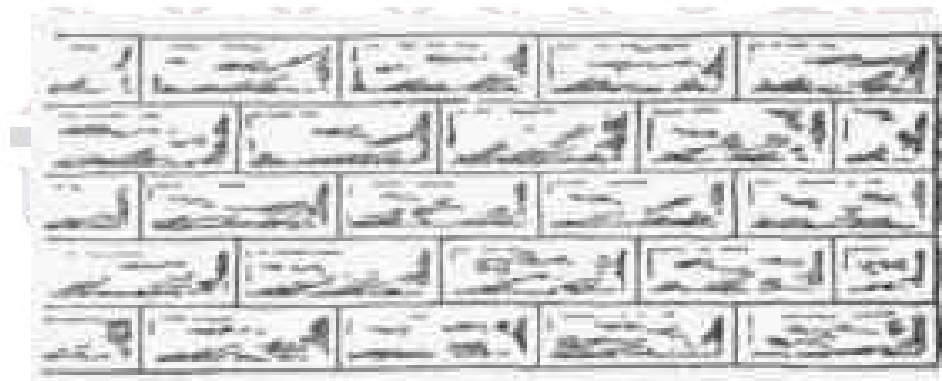


2. **Ashlar rough-tooled masonry:** In this type of ashlar masonry, the beds and sides are finely chisel-dressed. But the face is made rough by means of tools. A strip, about 25 mm wide and made by means of a chisel, is provided around the perimeter of every One

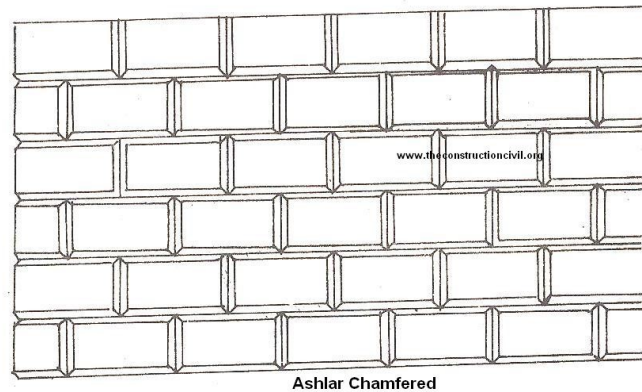
exposed for view, The thickness of mortar joints does not exceed 6 mm. This type of work is also known as the bastard ashlar.



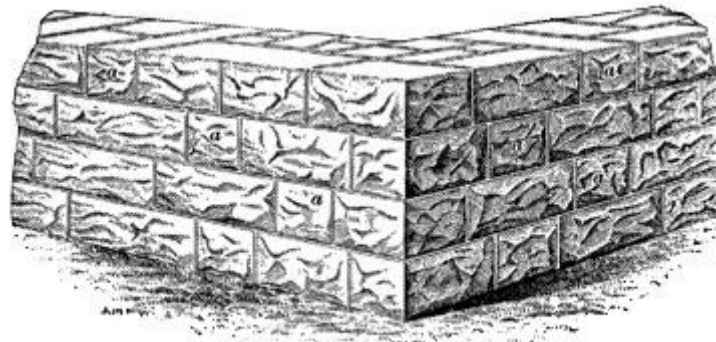
- Ashlar rock or quarry faced masonry:** In this type of ashlar masonry, a strip about 25 mm wide and made by means of a chisel, is provided around the perimeter of every stone exposed 'for view as in cage of rough-tooled ashlar. But the remaining portion of the face is left in the same form as received from quarry. Only projections on the face, known as the bushings, exceeding 80 mm are removed by a hammer. This type of construction gives massive appearance.



- Ashlar chamfered masonry:** In this type of ashlar masonry, the strip is provided as above. But it is chamfered or bevelled at an angle of 45 degrees by means of chisel for a depth of about 25 mm. Another strip 12 mm wide is then provided on the remaining exposed face of the stone and the surface inside this strip is left in the same form as received from quarry. The large bushings Projecting more than 80 mm are removed by a hammer. A neat appearance of the grooved joints is obtained with the help of this type of construction.



5. **Ashlar block-in-course masonry:** This type of ashlar masonry occupies an intermediate position between the rubble masonry and the ashlar masonry. The faces of the stones are generally hammer dressed and the thickness of mortar joints does not exceed 6 mm. The depth of courses varies from 200 mm to 300 mm.



ALLIANCE
UNIVERSITY
Alliance College of Engineering and Design