

**E-Learning Material**  
on  
**Engineering Mechanics**  
Of  
1<sup>st</sup>/2<sup>nd</sup> semester of all Engineering Branches



**State Council for Technical Education and  
Vocational Training, Odisha  
Bhubaneswar-751012**

**E-Learning Material**

# **Engineering Mechanics**

of  
1<sup>st</sup>/2<sup>nd</sup> semester of all Engineering Branches of Diploma courses of  
SCTE&VT, Odisha

*Contents Written by*

<b>SRI SOUMYA RANJAN MISHRA</b>	<b>LECTURER, UGIE RKL</b>
<b>SRI THAKURA HANSDAH</b>	<b>LECTURER, UGIE RKL</b>
<b>SRI KALEBAR SINGH</b>	<b>LECTURER, UGIE RKL</b>
<b>MISS MONALISHA SWAIN</b>	<b>LECTURER, UGIE RKL</b>

*Reviewed and validated by*

<b>Mr. MANAS KUMAR MISHRA</b>	<b>LECTURER, GP JAJPUR</b>
<b>Mrs. SUPRAVA BEHERA</b>	<b>LECTURER, GP JAJPUR</b>

All rights are reserved by SCTE&VT, Odisha. This material is meant to be used by students of Diploma Course of SCTE&VT, Odisha, as downloadable from SCTE&VT website free of cost. This material is not to be treated as Text Book, but be treated as reference material.

Published by  
SCTE&VT, Odisha, Bhubaneswar-12  
<https://sctevtodisha.nic.in/en/>  
secretarysctevt@gmail.com, [material.sctevt@gmail.com](mailto:material.sctevt@gmail.com)

# CONTENTS

## 1. FUNDAMENTALS OF ENGINEERING MECHANICS ( 4 – 45 )

- 1.1 Engineering mechanics, divisions of engineering mechanics, statics, dynamics, fundamental units, derived units, systems of units, fundamental SI units, some S.I derived units, mass and weight, difference between mass and weight, rigid body and elastic body, scalar and vector.
- 1.2 Force - force system, units of force, effect of force, characteristics of a force, principle of physical independence of forces, system of forces, coplanar forces, collinear forces, concurrent forces, collinear forces, concurrent forces, coplanar concurrent forces, coplanar non-concurrent forces, non-coplanar concurrent forces, non-coplanar non-concurrent forces, pull and push, action and reaction, free body diagram, external force and internal force, tension, representation of a force, denoting a force by bow's notation, principle of transmissibility of forces, principle of superposition of forces.
- 1.3 Resolution of a force, resolution of a given force into two components in two assigned direction, determination of resolved parts of a force, significance of the resolved parts of a force
- 1.4 Resultant and component, equilibrant, equal forces, methods for finding the resultant force, 1.4.1 Analytical method for resultant force, parallelogram law of forces, determination of the resultant of two concurrent forces with the help of law of parallelogram of forces, difference between components and resolved parts, analytical method of determining the resultant of any number of co-planar concurrent forces. 1.4.2 Graphical method - triangle law of forces, polygon law of forces, graphical conditions of equilibrium of a system of co-planar concurrent forces, space diagram, vector diagram and bow's notation. Classification of parallel forces - like parallel forces, unlike parallel forces, 1.4.3 Analytical method of determination of the resultant of a system of like and unlike parallel forces , analytical method of determining the point of application of the resultant of a system of like and unlike non concurrent parallel forces, graphical method for the resultant of parallel forces.
- 1.5 Moment of a force - moment of a force about an axis types of moments - clockwise moment, anticlockwise moment , positive moment and negative moment, algebraic sum of the moments, geometrical representation of the moment of the force about a point, Varignon's theorem, principle of moments. Couple - arm of a couple, moment of a couple. Classification of couples – clockwise couple, anticlockwise couple, units of couple, characteristics of a couple, exercises

## 2. EQUILLIBRIUM ( 46 – 59 )

- 2.1 Definition, principles of equilibrium, analytical conditions of equilibrium of a co-planar system of concurrent forces, analytical conditions of equilibrium of a system of coplanar non-concurrent forces, types of equilibrium - stable equilibrium, unstable equilibrium, neutral equilibrium, free body diagram, method of equilibrium of coplanar forces - analytical method, graphical method,
- 2.2 Lami's theorem, graphical method for the equilibrium of coplanar forces, converse of the law of triangle of forces, converse of the law of polygon of forces, exercises

### **3. FRICTION ( 60 - 82)**

- 3.1 Frictional force, static, dynamic & limiting friction, normal reaction, angle of repose, coefficient of friction, laws of static friction, laws of kinetic or dynamic friction, advantages of friction , disadvantages of friction.
- 3.2 Equilibrium of bodies on level plane, equilibrium of a body on a rough horizontal plane, equilibrium of a body on a rough inclined plane - equilibrium of a body on a rough inclined plane subjected to a force acting along the inclined plane, equilibrium of a body on a rough inclined plane subjected to a force acting horizontally, equilibrium of a body on a rough inclined plane subjected to a force acting at some angle with the inclined plane,
- 3.3 Applications of friction - ladder friction, wedge friction, graphical method, analytical method, exercises

### **4. CENTROID AND MOMENT OF INERTIA ( 83 – 107 )**

- 4.1 **Centroid** – Introduction, Centre of gravity (C.G), centroid definition, methods for centre of gravity, centre of gravity by moments, centre of gravity by moments, axis of reference, centre of gravity of plane figures, centroid of various crosssections, centroids of solid bodies, centre of gravity of symmetrical sections, centre of gravity of unsymmetrical sections
- 4.2 **Moment of inertia** - Introduction, calculation of moment of inertia by integration method, theorem of perpendicular axis, theorem of parallel axis, moment of inertia of a rectangular section, moment of inertia of a hollow rectangular section, moment of inertia of a circular section, moment of inertia of a hollow circular section, moment of inertia of a composite section, moment of inertia of a triangular section, moment of inertia of some geometric shapes, exercises

### **5. SIMPLE MACHINES ( 108 – 129 )**

- 5.1 Introduction simple machine, compound machine, simple gear drive, simple gear train, velocity ratio of a simple gear train, velocity ratio, compound gear train, terminology in simple lifting machine- (M.A, V.R. &Efficiency and relation between them), law of machine, maximum mechanical advantage (max. M.A.), maximum efficiency, reversible machine, condition for reversible machine, irreversible machine / non-reversible machine / self-locking machine, condition for irreversible machine, friction in machines in terms of effort and load,
- 5.2 Study of simple machines, simple wheel and axle, single purchase crab winch, double purchase crab winch, worm and worm wheel, screw jack,
- 5.3 Hoisting machine - pulley and sheave block, chain hoists, cranes, mobile crane, truck mounted crane, tower crane, overhead crane, derrick cranes, exercises

### **6. DYNAMICS ( 130 – 145 )**

- 6.1 Kinematics and kinetics, principles of dynamics- Newton's laws of motion ( first law of motion, second law of motion, third law of motion). Motion of particle acted upon by a constant force, equations of motion, D' Alembert's principle, recoil of gun,
- 6.2 Work, power, energy - potential energy, kinetic energy.
- 6.3 Momentum and Impulse, law of conservation of linear momentum, law of conservation of energy, collision of elastic bodies, Newton's law of collision of elastic

bodies and coefficient of restitution, direct collision of two bodies, direct impact of a body with a fixed plane, exercises

**REFERENCES (146)**

## Syllabus

### **Th.4. ENGINEERING MECHANICS (1<sup>ST</sup> & 2<sup>ND</sup> semester Common)**

Theory: 4 Periods per Week  
Total Periods: 60 Periods  
Examination: 3 Hours

I.A : 20 Marks  
End Sem Exam : 80 Marks  
TOTAL MARKS : 100 Marks

#### **Objective:**

**On completion of the subject, the student will be able to do:**

1. Compute the force, moment & their application through solving of simple problems on coplanar forces.
2. Understand the concept of equilibrium of rigid bodies.
3. Know the existence of friction & its applications through solution of problems on above.
4. Locate the C.G. & find M.I. of different geometrical figures.
5. Know the application of simple lifting machines.
6. Understand the principles of dynamics.

#### **Topic wise distribution of periods**

Serial no	Topics	Periods
01	Fundamentals of Engineering Mechanics	14
02	Equilibrium	08
03	Friction	10
04	Centroid & Moment of Inertia	14
05	Simple Machines	08
06	Dynamics	06
	Total	60

#### **1. FUNDAMENTALS OF ENGINEERING MECHANICS**

1.1 Fundamentals.

Definitions of Mechanics, Statics, Dynamics, Rigid Bodies,

1.2 Force

Force System.

Definition, Classification of force system according to plane & line of action. Characteristics of Force & effect of Force. Principles of Transmissibility & Principles of Superposition. Action &

Reaction Forces & concept of Free Body Diagram.

1.3 Resolution of a Force.

Definition, Method of Resolution, Types of Component forces, Perpendicular components & non-perpendicular components.

1.4 Composition of Forces.

Definition, Resultant Force, Method of composition of forces, such as

1.4.1 Analytical Method such as Law of Parallelogram of forces & method of resolution.

1.4.2. Graphical Method.

Introduction, Space diagram, Vector diagram, Polygon law of forces.

1.4.3 Resultant of concurrent, non-concurrent & parallel force system by Analytical & Graphical Method.

1.5 Moment of Force.

Definition, Geometrical meaning of moment of a force, measurement of moment of a force & its S.I units. Classification of moments according to direction of rotation, sign convention, Law of moments, Varignon's Theorem,

Couple – Definition, S.I. units, measurement of couple, properties of couple.

## **2. EQUILIBRIUM**

2.1 Definition, condition of equilibrium, Analytical & Graphical conditions of equilibrium for concurrent, non-concurrent & Free Body Diagram.

2.2 Lamia's Theorem – Statement, Application for solving various engineering problems.

## **3. FRICTION**

3.1 Definition of friction, Frictional forces, Limiting frictional force, Coefficient of Friction. Angle of Friction & Repose, Laws of Friction, Advantages & Disadvantages of Friction.

3.2 Equilibrium of bodies on level plane – Force applied on horizontal & inclined plane (up & down).

3.3 Ladder, Wedge Friction.

## **4. CENTROID & MOMENT OF INERTIA**

4.1 Centroid – Definition, Moment of an area about an axis, centroid of geometrical figures such as squares, rectangles, triangles, circles, semicircles & quarter circles, centroid of composite figures.

4.2 Moment of Inertia – Definition, Parallel axis & Perpendicular axis Theorems. M.I. of plane lamina & different engineering sections.

## **5. SIMPLE MACHINES**

5.1 Definition of simple machine, velocity ratio of simple and compound gear train, explain simple & compound lifting machine, define M.A, V.R. & Efficiency & State the relation between them, State Law of Machine, Reversibility of Machine, Self Locking Machine.

5.2 Study of simple machines – simple axle & wheel, single purchase crab winch & double purchase crab winch, Worm & Worm Wheel, Screw Jack.

5.3 Types of hoisting machine like derricks etc, Their use and working principle. No problems.

## **6. DYNAMICS**

6.1 Kinematics & Kinetics, Principles of Dynamics, Newton's Laws of Motion, Motion of Particle acted upon by a constant force, Equations of motion, DeAlembert's Principle.

6.2 Work, Power, Energy & its Engineering Applications, Kinetic & Potential energy & its

application.

6.3 Momentum & impulse, conservation of energy & linear momentum, collision of elastic bodies, and Coefficient of Restitution.

### **Books Recommended**

1. Engineering Mechanics – by A.R. Basu (TMH Publication Delhi)
2. Engineering Machines – Basudev Bhattacharya (Oxford University Press).
3. Text Book of Engineering Mechanics – R.S Khurmi (S. Chand).
4. Applied Mechanics & Strength of Material – By I.B. Prasad.
5. Engineering Mechanics – By Timosheenko, Young & Rao.
6. Engineering Mechanics – Beer & Johnson (TMH Publication).



# CHAPTER 1: FUNDAMENTALS OF ENGINEERING MECHANICS

## LEARNING OUTCOMES:

On completion of the subject, the student will be able to:

- Define and classify Mechanics
- Define and classify the forces and its system.
- Compute the force and apply it for solving problems on coplanar forces.
- Understand and apply resolution of forces.
- Understand composition of forces and apply it to solve problems
- Understand Moment of force, Varignon's theorem with applications, couple.

## 1.1 FUNDAMENTALS

### ENGINEERING MECHANICS

Mechanics is that branch of physical science which deals with the action of forces on material bodies. Engineering Mechanics, which is very often referred to as Applied Mechanics, deals with the practical applications of mechanics in the field of engineering. Applications of Engineering Mechanics are found in analysis of forces in the components of roof truss, bridge truss, machine parts, parts of heat engines, rocket engineering, aircraft design etc.

### DIVISIONS OF ENGINEERING MECHANICS

The subject of Engineering Mechanics may be divided into the following two main groups:

1. Statics and 2. Dynamics.

#### STATICS

It is the branch of Engineering Mechanics, which deals with the forces and their effects, while acting upon the bodies at rest.

#### DYNAMICS

It is the branch of Engineering Mechanics, which deals with the forces and their effects, while acting upon the bodies in motion. Dynamics may be further sub-divided into the following two branches:

1. Kinematics
2. Kinetics

Kinetic deals with the forces acting on moving bodies, whereas kinematics deals with the motion of the bodies without any reference to forces responsible for the motion.

#### FUNDAMENTAL UNITS

Every quantity is measured in terms of some internationally accepted units, called fundamental units.

All the physical quantities in Engineering Mechanics are expressed in terms of three fundamental quantities, *i.e.*

1. Length 2. Mass and 3. Time

## DERIVED UNITS

Sometimes, the units are also expressed in other units (which are derived from fundamental units) known as derived units e.g. units of area, velocity, acceleration, pressure etc.

## SYSTEMS OF UNITS

There are only four systems of units, which are commonly used and universally recognized.

These are known as:

1. C.G.S. units
2. F.P.S. units
3. M.K.S. units
- and 4. S.I. units.

In this study material we shall use only the S.I. system of units.

## FUNDAMENTAL S.I UNITS

QUANTITIES	FUNDAMENTAL UNIT	SYMBOL
Length	Meter	m
Mass	Kilogram	Kg
Time	Second	S
Electric current	Ampere	A
Luminous intensity	Candela	Cd
Thermodynamic temperature	Kelvin	K

## SOME S.I DERIVED UNITS

QUANTITIES	DERIVED UNIT	SYMBOL
Force	Newton	N
Moment	Newton-meter	Nm
Work done	Joule	J
Power	Watt	W
Velocity	Meter per second	m/s
Pressure	Pascal or Newton per square meter	Pa or N/m <sup>2</sup>

## MASS AND WEIGHT

Mass of a body is the total quantity of matter contained in the body.

Weight of a body is the force with which the body is attracted towards the centre of the earth.

## DIFFERENCE BETWEEN MASS AND WEIGHT

MASS	WEIGHT
1. Mass is the total quantity of matter contained in a body.	1. Weight of a body is the force with which the body is attracted towards the centre of the earth.
2. Mass is a scalar quantity, because it has only magnitude and no direction.	2. Weight is a vector quantity, because it has both magnitude and direction.
3. Mass of a body remains the same at all places. Mass of a body will be the same whether the body is taken to the centre of the earth or to the moon.	3. Weight of body varies from place to place due to variation of 'g' (i.e., acceleration due to gravity).
4. Mass resists motion in a body.	4. Weight produces motion in a body.
5. Mass can be measured by an ordinary balance.	5. It can be measured by a spring balance.

6. Mass of a body can never be zero.

6. Weight of a body can be zero.

## RIGID BODY AND ELASTIC BODY

A body is said to be rigid if it does not undergo deformation whatever force may be applied to the body. In actual practice, there is no body which can be said to be rigid in true sense of terms.

A body is said to be elastic if it undergoes deformation under the action of force. All bodies are more or less elastic.

## SCALAR AND VECTOR

All physical quantities can be divided into scalar quantity and vector quantity. Scalar quantity is that physical quantity which has only magnitude and no direction. For example, length, mass, energy etc. Vector quantity is that physical quantity which has both magnitude and direction. For example, force, velocity etc.

## 1.2 FORCE

### FORCE SYSTEM

Force is that which changes or tends to change the state of rest or uniform motion of a body along a straight line. It may also deform a body changing its dimensions. The force may be broadly defined as an agent which produces or tends to produce, destroys or tends to destroy motion. It has a magnitude and direction.

Mathematically:

$$\text{Force} = \text{Mass} \times \text{Acceleration.}$$

Where  $F$ =force,  $M$ =mass and  $A$ =acceleration.

### UNITS OF FORCE

**In C.G.S. System:** In this system, there are two units of force: (1) Dyne and (ii) Gram force (gmf). Dyne is the absolute unit of force in the C.G.S. system. One dyne is that force which acting on a mass of one gram produces in it an acceleration of one centimeter per second<sup>2</sup>.

**In M.K.S. System:** In this system, unit of force is kilogram force (kgf). One kilogram force is that force which acting on a mass of one kilogram produces in it an acceleration of 9.81 m/sec<sup>2</sup>.

**In S.I. Unit:** In this system, unit of force is Newton (N). One Newton is that force which acting on a mass of one kilogram produces in it an acceleration of one m/sec<sup>2</sup>.

$$1 \text{ Newton} = 10^5 \text{ Dyne.}$$

### EFFECT OF FORCE

A force may produce the following effects in a body, on which it acts:

1. It may change the motion of a body. *i.e.* if a body is at rest, the force may set it in motion. And if the body is already in motion, the force may accelerate or decelerate it.
2. It may retard the forces, already acting on a body, thus bringing it to rest or in equilibrium.
3. It may give rise to the internal stresses in the body, on which it acts.
4. A force can change the direction of a moving object.
5. A force can change the shape and size of an object

## CHARACTERISTICS OF A FORCE

In order to determine the effects of a force, acting on a body, we must know the following characteristics of a force:

1. Magnitude of the force (*i.e.*, 50 N, 30 N, 20N etc.)
2. The direction of the line, along which the force acts (*i.e.*, along *West*, at 30° North of East etc.). It is also known as line of action of the force.
3. Nature of the force (push or pull).
4. The point at which (or through which) the force acts on the body.

## PRINCIPLE OF PHYSICAL INDEPENDENCE OF FORCES

It states, "If a number of forces are simultaneously acting on a particle, then the resultant of these forces will have the same effect as produced by all the forces".

## SYSTEM OF FORCES

When two or more forces act on a body, they are called to form a system of forces. Force system is basically classified into following types.

- i. Coplanar forces
- ii. Collinear forces
- iii. Concurrent forces
- iv. Coplanar concurrent forces
- v. Coplanar non- concurrent forces
- vi. Non-coplanar concurrent forces
- vii. Non- coplanar non- concurrent force

**COPLANAR FORCES:** The forces, whose lines of action lie on the same plane, are known as coplanar forces.

**COLLINEAR FORCES:** The forces, whose lines of action lie on the same line, are known as collinear forces. They act along the same line. Collinear forces may act in the opposite directions or in the same direction.

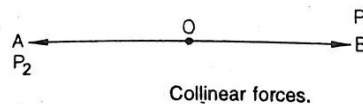

Fig 1.1

**CONCURRENT FORCES:** The forces, whose lines of action pass through a common point, are known as concurrent forces. The concurrent forces may or may not be collinear

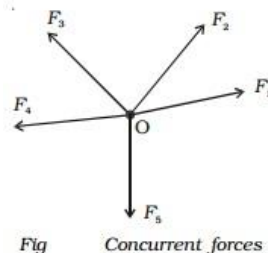

Fig. 1.2

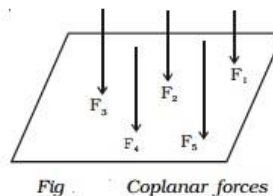
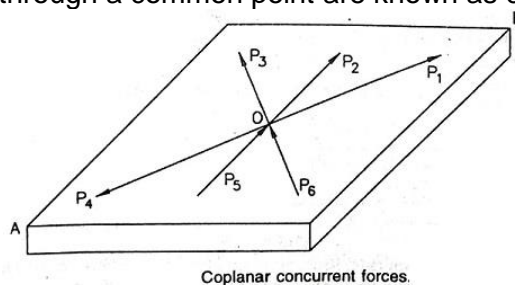

Fig. 1.3

**COPLANAR CONCURRENT FORCES:** The forces, whose lines of action lie in the same plane and at the same time pass through a common point are known as coplanar concurrent forces.



Coplanar concurrent forces.

Fig 1.4

**COPLANAR NON-CONCURRENT FORCES:** The forces, which do not meet at one point, but their lines of action lie on the same plane, are known as coplanar non-concurrent forces.

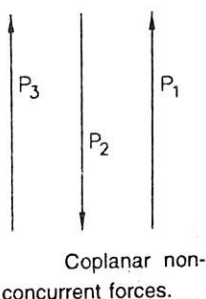

Coplanar non-concurrent forces.

Fig 1.5

**NON-COPLANAR CONCURRENT FORCES:** The forces, which meet at one point, but their lines of action do not lie on the same plane, are known as non-coplanar concurrent forces.

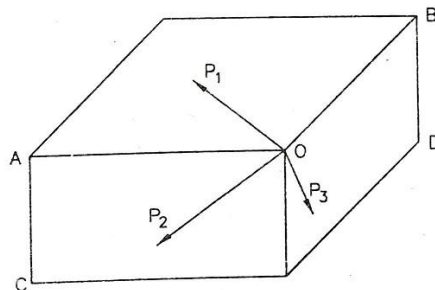

Non-coplanar concurrent forces.

Fig 1.6

**NON-COPLANAR NON-CONCURRENT FORCES:** The forces, which do not meet at one point and their lines of action do not lie on the same plane, are called non-coplanar non-concurrent forces.

**PULL AND PUSH:** Pull is the force applied to a body at its front end to move the body in the direction of the force applied.

Push is the force applied to a body at its back end in order to move the body in the direction of the force applied.

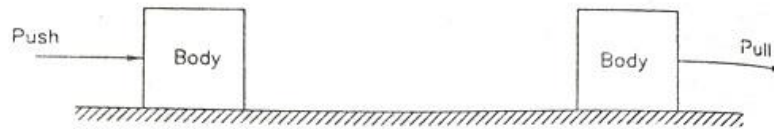

Fig 1.7 push and pull

**ACTION AND REACTION:** Action means active force. Reaction means reactive force. When a body having a weight  $W (=mg)$  is placed on a horizontal plane as shown in Fig 1.8, the body exerts a vertically downward force equal to 'W' or 'mg' on the plane. Then 'W' is called action of the body on the plane. According to Newton's 3<sup>rd</sup> law of motion, every action has an equal and opposite reaction. But action and reaction never act on the same body. So, the horizontal plane will exert equal amount of force 'R' on the body in the vertically upward direction. This vertically upward force acting on the body is called reaction of the plane on the body.

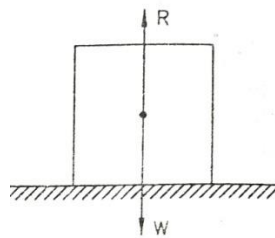
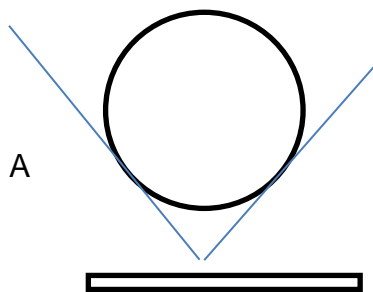

Fig 1.8 Action and reaction

**FREE BODY DIAGRAM:**

The representation of reaction force on the body by removing all the support or forces act from the body is called free body diagram.



Object with support

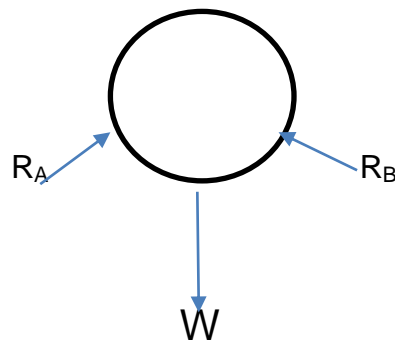

Free Body Diagram

Fig.1.9

**EXTERNAL FORCE AND INTERNAL FORCE:** When a force is applied externally to a body; that force is called external force.

Internal force is that force which is set up in a body to resist deformation of the body caused by the external force.

**TENSION:** Tension is the pull to which a rope or wire or rod is subjected. In figure 1.10 (b) P is the tension applied to a rope.

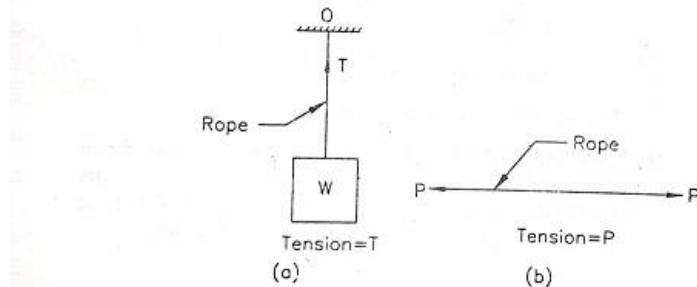

Fig 1.10 Tension

Let a body having weight  $W$  be suspended by means of a vertical rope fixed at its upper end at  $O$ . The point  $O$  is pulled downward by a force  $W$ . Hence the point  $O$  will exert equal amount of force  $W$  to the body, in the upward direction. This upward force on the rope is the tension of the rope. In Fig 1.10(a),  $T$  is the tension of the rope.

### REPRESENTATION OF A FORCE

Since force is a vector quantity, it can be represented by a straight line. The length of the line represents magnitude of the force, the line itself represents the direction and an arrow put on the head of the straight line indicates the sense in which the force acts.

### DENOTING A FORCE BY BOW'S NOTATION

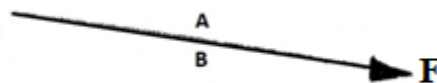

Fig 1.11

In Bow's notation for denoting a force, two English capital letters are placed, one on each side of the line of action of the force. In figure 1.11  $AB$  denotes the force  $F$ .

### PRINCIPLE OF TRANSMISSIBILITY OF FORCES

It states, "If a force acts at any point on a rigid body, it may also be considered to act at any other point on its line of action, provided this point is rigidly connected with the body." That means the point of application of a force can be moved anywhere along its line of action without changing the external reaction forces on a rigid body.

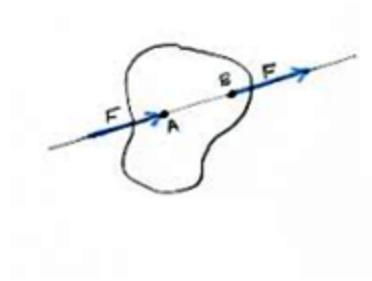

Fig 1.12

Here force at point A = force at B (the magnitude of force in the body at any point along the line of action are same)

**PRINCIPLE OF SUPERPOSITION OF FORCES:** This principle states that the combined effect of force system acting on a particle or a rigid body is the sum of effects of individual forces.

Consider two forces P and Q acting at A on a boat as shown in Fig 1.13. Let R be the resultant of these two forces P and Q. According to Newton's second law of motion, the boat will move in the direction of resultant force R with acceleration proportional to R. The same motion can be obtained when P and Q are applied simultaneously.

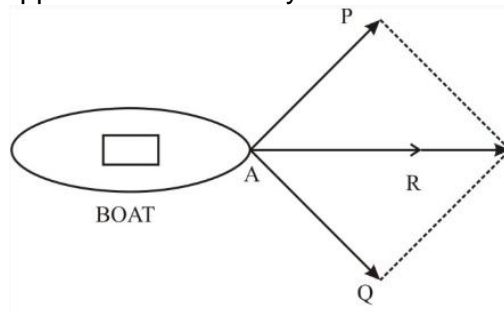
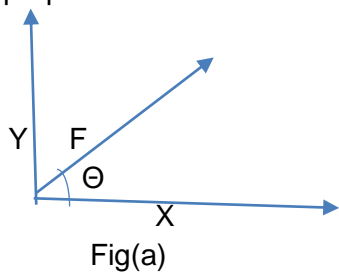

Fig 1.13

### 1.3 RESOLUTION OF A FORCE

#### RESOLUTION OF A FORCE

The process of splitting up the given force into a number of components, without changing its effect on the body is called resolution of a force. A force is, generally, resolved along two mutually perpendicular directions.



Fig(a)

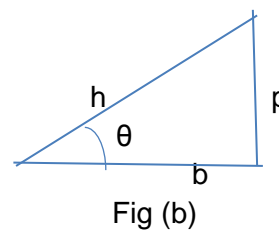

Fig (b)

Fig 1.14



(From Pythagoras theorem we know that

$$\sin\theta = \frac{p}{h} \Rightarrow p = h\sin\theta \quad \text{similarly} \quad \cos\theta = \frac{b}{h} \Rightarrow b = h\cos\theta$$

By resolution of force  $F$ , we found

$$X = F\cos\theta \quad \text{and} \quad Y = F\sin\theta$$

## RESOLUTION OF A GIVEN FORCE INTO TWO COMPONENTS IN TWO ASSIGNED DIRECTION

Let  $P$  be the given force represented in magnitude and direction by  $OB$  as shown in Fig 1.15. Also let  $OX$  and  $OY$  be two given direction along which the components of  $P$  are to be found out.

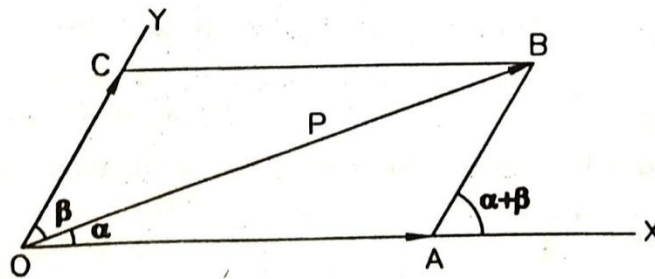

Fig 1.15

Let  $\angle BOX = \alpha$  and  $\angle BOY = \beta$

From  $B$ , lines  $BA$  and  $BC$  are drawn parallel to  $OY$  and  $OX$  respectively. Then the required components of the given force  $P$  along  $OX$  and  $OY$  are represented in magnitude and direction by  $OA$  and  $OC$  respectively. Since  $AB$  is parallel to  $OC$ ,  $\angle BAX = \angle AOC = \alpha + \beta$

$$\angle AOB = 180^\circ - (\alpha + \beta)$$

Now, in  $\triangle OAB$

$$\frac{OA}{\sin \angle OBA} = \frac{AB}{\sin \angle AOB} = \frac{OB}{\sin \angle OAB}$$

$$\text{Or } \frac{OA}{\sin \beta} = \frac{AB}{\sin \alpha} = \frac{OB}{\sin 180^\circ - (\alpha + \beta)}$$

$$\frac{OA}{\sin \beta} = \frac{AB}{\sin \alpha} = \frac{P}{\sin (\alpha + \beta)}$$

$$OA = \frac{P \sin \beta}{\sin (\alpha + \beta)}, \quad \text{and} \quad AB = \frac{P \sin \alpha}{\sin (\alpha + \beta)}$$

But  $AB = OC$

$$\text{i.e. } OC = \frac{P \sin \alpha}{\sin (\alpha + \beta)}$$

## DETERMINATION OF RESOLVED PARTS OF A FORCE

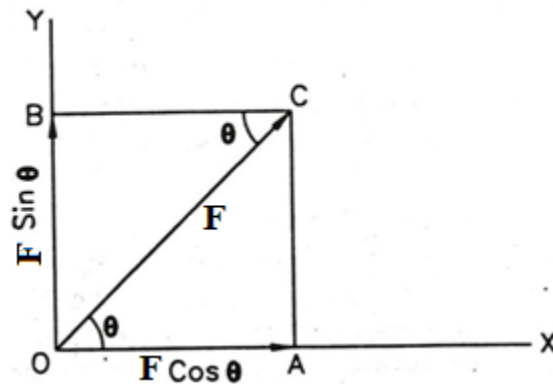

Fig 1.16

Resolved parts of a force mean components of the force along two mutually perpendicular directions.

Let a force  $F$  represented in magnitude and direction by  $OC$  make an angle  $\theta$  with  $OX$ . Line  $OY$  is drawn through  $O$  at right angles to  $OX$  as shown in figure 1.16.

Through  $C$ , lines  $CA$  and  $CB$  are drawn parallel to  $OY$  and  $OX$  respectively. Then the resolved parts of the force  $F$  along  $OX$  and  $OY$  are represented in magnitude and direction by  $OA$  and  $OB$  respectively.

Now in the right angled  $\Delta AOC$ ,

$$\cos \theta = OA / OC = OA / F \quad \text{i.e. } OA = F \cos \theta$$

Since  $OA$  is parallel to  $BC$ ,  $\angle OCB = \angle AOC = \theta$

In the right angled  $\Delta OBC$ ,  $\sin \theta = OB / OC = OB / F$  i.e.,  $OB = F \sin \theta$

Thus, the resolved parts of  $F$  along  $OX$  and  $OY$  are respectively.  $F \cos \theta$  and  $F \sin \theta$ .

## SIGNIFICANCE OF THE RESOLVED PARTS OF A FORCE

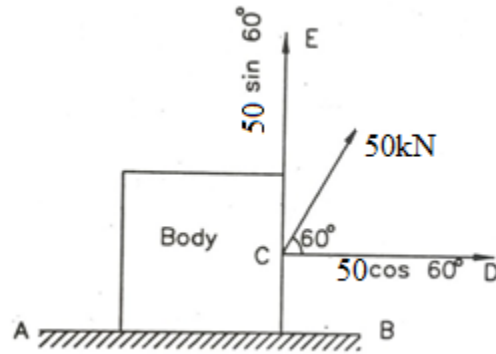

Fig 1.17

Let 50 kN force is required to be applied to a body along a horizontal direction CD in order to move the body along the plane AB. Then it can be said that to move the body along the same plane AB, a force of 50 kN is to be applied at an angle of  $60^\circ$  with the horizontal as  $CD = 50 \cos 60^\circ = 25 \text{ kN}$ .

Similarly, if a force of 43.3 kN is required to be applied to the body to lift it vertically upward, then the body will be lifted vertically upward if a force of 50 kN is applied to the body at an angle of  $60^\circ$  with the horizontal, as the resolved part of 50 kN along the vertical  $CE = 50 \sin 60^\circ = 43.3 \text{ kN}$ .

Thus, the resolved part of a force in any direction represents the whole effect of the force in that direction.

### 1.4 RESULTANT AND COMPONENT

Resultant of two or more forces is a single force whose effect on a body is the same as the given forces taken together acting on the body. In figure 1.20, **R** is the resultant of forces **P** and **Q**.

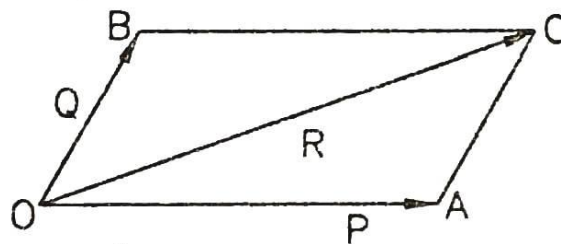

Fig 1.18 Resultant and component

If R is the resultant of two forces P and Q, it means forces P and Q can be replaced by R. Similarly, R can be replaced by two forces P and Q whose joint effect on a body will be the same as R on the body. Then these two forces P and Q are called components of R.

Or we can say:

If a number of forces, P, Q, R ... etc are acting simultaneously on a particle, then it is possible to find out a single force which could replace them i.e., which would produce the same effect as produced by all the given forces. This single force is called resultant force and the given forces P, Q, R ...etc are called component forces.

## EQUILIBRIANT

Equilibrant of a system of forces is a single force which will keep the given forces in equilibrium. Evidently, equilibrant is equal and opposite to the resultant of the given forces.

## EQUAL FORCES

Two forces are said to be equal when acting on a particle along the same line but in opposite directions, keeping the particle at rest.

## METHODS FOR FINDING THE RESULTANT FORCE

Though there are many methods for finding out the resultant force of a number of given forces, yet the following are important from the subject point of view :

1. Analytical method.
2. Method of resolution.

### 1.4.1 ANALYTICAL METHOD FOR RESULTANT FORCE

The resultant force, of a given system of forces, may be found out analytically by the following methods

1. Parallelogram law of forces.
2. Method of resolution.

### PARALLELOGRAM LAW OF FORCES

This theorem states that if two forces acting at a point be represented in magnitude and direction by the two adjacent sides of a parallelogram drawn from a point, then their resultant is represented in magnitude and direction by the diagonal of the parallelogram passing through that point.

Explanation: Let forces P and Q acting at a point O be represented in magnitude and direction by OA and OB respectively as shown in Fig 1.19. Then, according to the theorem of parallelogram of forces, the diagonal OC drawn through O represents the resultant of P and Q in magnitude and direction.

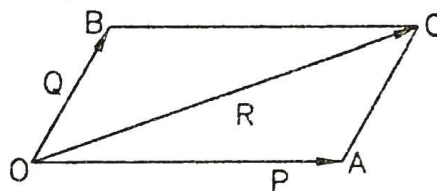

Fig 1.19

**DETERMINATION OF THE RESULTANT OF TWO CONCURRENT FORCES WITH THE HELP OF LAW OF PARALLELOGRAM OF FORCES**

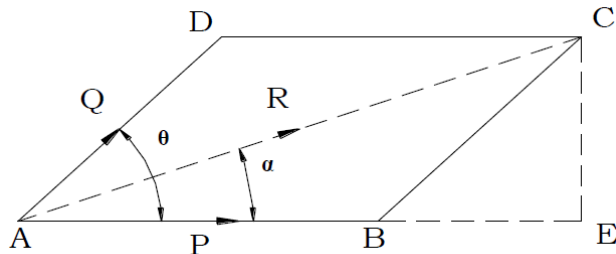

Fig 1.20

Consider, two forces 'P' and 'Q' acting at and away from point 'A' as shown in figure 1.20.

Let, the forces P and Q are represented by the two adjacent sides of a parallelogram AD and AB respectively as shown in fig. Let,  $\theta$  be the angle between the force P and Q and  $\alpha$  be the angle between R and P. Extend line AB and drop perpendicular from point C on the extended line AB to meet at point E.

Consider Right angle triangle ACE,

$$\begin{aligned} AC^2 &= AE^2 + CE^2 \\ &= (AB + BE)^2 + CE^2 \\ &= AB^2 + BE^2 + 2.AB.BE + CE^2 \\ &= AB^2 + BE^2 + CE^2 + 2.AB.BE \dots \dots \dots (1) \end{aligned}$$

Consider right angle triangle BCE,  
 $BC^2 = BE^2 + CE^2$  and  $BE = BC.\cos \theta$

Putting  $BC^2 = BE^2 + CE^2$  in equation (1), we get

$$AC^2 = AB^2 + BC^2 + 2.AB.BE \dots \dots \dots (2)$$

Putting  $BE = BC.\cos \theta$  in equation (2)

$$AC^2 = AB^2 + BC^2 + 2.AB.BC.\cos \theta$$

But,  $AB = P$ ,  $BC = Q$  and  $AC = R$

$$R = \sqrt{P^2 + Q^2 + 2PQ \cos \theta}$$

In triangle ACE

$$\tan \alpha = \frac{CE}{AE} = \frac{CE}{AB + BE}$$

But,  $CE = BC \cdot \sin \theta$

$$\tan \alpha = \frac{Q \sin \theta}{P + Q \cos \theta}$$

**Now let us consider two forces  $F_1$  and  $F_2$  are represented by the two adjacent sides of a parallelogram**

i.e.  $F_1$  and  $F_2$  = Forces whose resultant is required to be found out,

$\theta$  = Angle between the forces  $F_1$  and  $F_2$ , and

$\alpha$  = Angle which the resultant force makes with one of the forces (say  $F_1$ ).

Then resultant force

$$R = \sqrt{F_1^2 + F_2^2 + 2F_1F_2 \cos \theta}$$

And

$$\tan \alpha = \frac{F_2 \sin \theta}{F_1 + F_2 \cos \theta}$$

If ( $\alpha$ ) is the angle which the resultant force makes with the other force  $F_2$ , then

$$\tan \alpha = \frac{F_1 \sin \theta}{F_2 + F_1 \cos \theta}$$

#### CASES:

1. If  $\theta = 0$  i.e., when the forces act along the same line, then

$$R_{max} = F_1 + F_2$$

2. If  $\theta = 90^\circ$  i.e., when the forces act at right angle, then

$$R = \sqrt{F_1^2 + F_2^2}$$

3. If  $\theta = 180^\circ$  i.e., when the forces act along the same straight line but in opposite directions, then

$$R_{min} = F_1 - F_2$$

In this case, the resultant force will act in the direction of the greater force.

4. If the two forces are equal i.e., when  $F_1 = F_2 = F$  then

$$\begin{aligned} R &= \sqrt{F^2 + F^2 + 2F^2 \cos \theta} = \sqrt{2F^2 (1 + \cos \theta)} \\ &= \sqrt{2F^2 \times 2 \cos^2 \left( \frac{\theta}{2} \right)} \quad \dots \left[ \because 1 + \cos \theta = 2 \cos^2 \left( \frac{\theta}{2} \right) \right] \\ &= \sqrt{4F^2 \cos^2 \left( \frac{\theta}{2} \right)} = 2F \cos \left( \frac{\theta}{2} \right) \end{aligned}$$

**Example 1.1** Two forces of 100 N and 150 N are acting simultaneously at a point. What is the resultant of these two forces, if the angle between them is  $45^\circ$ ?

**Solution.** Given: First force ( $F_1$ ) = 100 N; Second force ( $F_2$ ) = 150 N and angle between  $F_1$  and  $F_2$  ( $\theta$ ) =  $45^\circ$

$$\begin{aligned} R &= \sqrt{F_1^2 + F_2^2 + 2F_1F_2 \cos \theta} \\ &= \sqrt{(100)^2 + (150)^2 + 2 \times 100 \times 150 \cos 45^\circ} \text{ N} \\ &= \sqrt{10\,000 + 22\,500 + (30\,000 \times 0.707)} \text{ N} \\ &= 232 \text{ N} \quad \text{Ans.} \end{aligned}$$

**Example 1.2** Find the magnitude of the two forces, such that if they act at right angles, their resultant is  $\sqrt{10}$  N. But if they act at  $60^\circ$ , their resultant is  $\sqrt{13}$  N.

**Solution:** Given: Two forces =  $F_1$  and  $F_2$ .

First of all, consider the two forces acting at right angles. We know that when the angle between the two given forces is  $90^\circ$ , then the resultant force ( $R$ )

$$\begin{aligned} \sqrt{10} &= \sqrt{F_1^2 + F_2^2} \\ 10 &= F_1^2 + F_2^2 \quad \dots(\text{Squaring both sides}) \end{aligned}$$

Similarly, when the angle between the two forces is  $60^\circ$ , then the resultant force ( $R$ )

$$\begin{aligned} \sqrt{13} &= \sqrt{F_1^2 + F_2^2 + 2F_1F_2 \cos 60^\circ} \\ 13 &= F_1^2 + F_2^2 + 2F_1F_2 \times 0.5 \quad \dots(\text{Squaring both sides}) \end{aligned}$$

$$F_1F_2 = 13 - 10 = 3 \quad \dots(\text{Substituting } F_1^2 + F_2^2 = 10)$$

$$\text{We know that } (F_1 + F_2)^2 = F_1^2 + F_2^2 + 2F_1F_2 = 10 + 6 = 16$$

$$\therefore F_1 + F_2 = \sqrt{16} = 4$$

$$\text{Similarly } (F_1 - F_2)^2 = F_1^2 + F_2^2 - 2F_1F_2 = 10 - 6 = 4$$

$$\therefore F_1 - F_2 = \sqrt{4} = 2$$

Solving equations (i) and (ii),

$$F_1 = 3 \text{ N} \quad \text{and} \quad F_2 = 1 \text{ N} \quad \text{Ans.}$$

## DIFFERENCE BETWEEN COMPONENTS AND RESOLVED PARTS

1. When a force is resolved into two parts along two mutually perpendicular directions, the parts along those directions are called resolved parts. But when a force is split into two parts along two assigned directions not at right angles to each other, those parts are called components of the force.

2. All resolved parts are components, but all components are not resolved parts.
3. The resolved part of force in a given direction represents the whole effect of the force in that direction. But the component of a force in a given direction does not represent the whole effect of the force in that direction.

**Note:**The algebraic sum of the resolved parts of two concurrent forces along any direction is equal to the resolved part of their resultant along the same direction.

### ANALYTICAL METHOD OF DETERMINING THE RESULTANT OF ANY NUMBER OF CO-PLANAR CONCURRENT FORCES

Let P, Q, T..... be a number of forces acting at a point O and let R be the required resultant of the given forces.

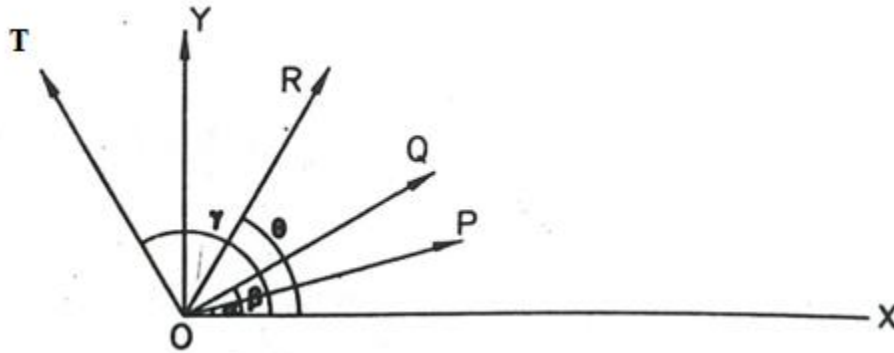

Fig 1.21

Through O, lines OX and OY are drawn at right angles to each other.

Let forces P, Q, T,..... make angles  $\alpha, \beta, \gamma, \dots$  with OX measured in the anticlockwise direction as shown in Fig. Also, let  $\theta$  = angle made by the line of action of R with OX.

Now, the resolved parts P, Q, T..... along OX are respectively  $P\cos\alpha, Q\cos\beta, T\cos\gamma$  and along OY are respectively  $P\sin\alpha, Q\sin\beta, T\sin\gamma$

Let  $\Sigma H = \Sigma X$  = algebraic sum of the resolved parts of the above forces along OX (horizontally)

$\Sigma V = \Sigma Y$  = algebraic sum of the resolved parts of the same forces along OY (vertically)

Then,  $\Sigma X = P\cos\alpha + Q\cos\beta + T\cos\gamma + \dots$

$$\Sigma Y = P\sin\alpha + Q\sin\beta + T\sin\gamma + \dots$$

Now, the resolved parts of R along OX and OY are respectively  $R\cos\theta$  and  $R\sin\theta$ .

$$\Sigma X = R\cos\theta, \text{ and } \Sigma Y = R\sin\theta$$



$$\begin{aligned}
(\Sigma X)^2 + (\Sigma Y)^2 &= R^2 \cos^2 \theta + R^2 \sin^2 \theta \\
&= R^2 (\cos^2 \theta + \sin^2 \theta) \\
&= R^2
\end{aligned}$$

$$R = \sqrt{(\Sigma X)^2 + (\Sigma Y)^2}$$

$$\frac{R \sin \theta}{R \cos \theta} = \frac{\Sigma Y}{\Sigma X} \quad \left( = \frac{\Sigma V}{\Sigma H} \right)$$

$$\tan \theta = \frac{\Sigma Y}{\Sigma X} \quad \left( = \frac{\Sigma V}{\Sigma H} \right)$$

From the above formula,  $\theta$  can be found out.

Note. When  $\Sigma X$  is +ve,  $R$  will lie either in between  $\theta = 0^\circ$  to  $90^\circ$  or between  $270^\circ$  to  $360^\circ$ .

When  $\Sigma X$  is -ve,  $R$  will lie in between  $90^\circ$  to  $270^\circ$ .

When  $\Sigma Y$  is +ve,  $R$  will lie in between  $0 = 0^\circ$  to  $180^\circ$ .

When  $\Sigma Y$  is -ve,  $R$  will lie in between  $180^\circ$  to  $360^\circ$ .

**Example 1.3A** A particle is acted on by three forces 2,  $2\sqrt{2}$  and 1 kN. The first force is horizontal and towards the right, the second acts at  $45^\circ$  to the horizontal and inclined right upward, and the third is vertical. Determine the resultant of the given forces.

**Solution.** See Figure. Let  $R$  = required resultant of the given forces.

Then,  $R = \sqrt{(\Sigma X)^2 + (\Sigma Y)^2}$ , where

$\Sigma X$  = algebraic sum of the resolved part of the given forces along horizontal direction OX, and

$\Sigma Y$  = algebraic sum of the resolved parts of the given forces along vertical direction OY.

Now,  $\Sigma X = 2 \cos 0^\circ + 2\sqrt{2} \cos 45^\circ + 1 \cos 90^\circ$

$$= 2 + 2\sqrt{2} \times \frac{1}{\sqrt{2}} + 0 = 4 \text{ kN}$$

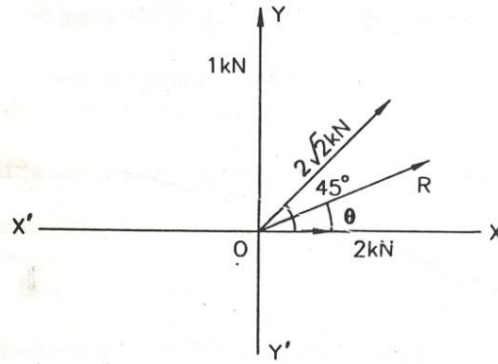

Fig 1.22

$$\Sigma Y = 2 \sin 0^\circ + 2\sqrt{2} \sin 45^\circ + 1 \sin 90^\circ$$

$$= 0 + 2\sqrt{2} \times \frac{1}{\sqrt{2}} + 1 = 3 \text{ kN}$$

$$R = \sqrt{4^2 + 3^2} = 5 \text{ kN}$$

$$\tan \theta = \frac{\Sigma Y}{\Sigma X} = \frac{3}{4} = 0.75 \Rightarrow \theta = \tan^{-1} 0.75 = 36.9^\circ$$

**Example 1.4.** To resolve the given force into two perpendicular co-ordinates.

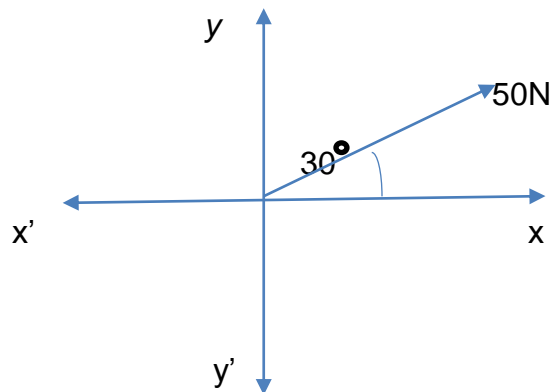

**Solution:**

According to resolution of forces:

We know that  $x = 50 \times \cos 30^\circ$ ,  $x = 50 \times 0.866$ ,  $x = 43.30 \text{ N}$  fig 1.23

$y = 50 \times \sin 30^\circ$ ,  $y = 50 \times \frac{1}{2}$   $y = 25 \text{ N}$

**Example 1.5** A triangle ABC has its side AB = 40 mm along positive x-axis and side BC = 30 mm along positive y-axis. Three forces of 40 N, 50 N and 30 N act along the sides AB, BC and CA respectively. Determine magnitude of the resultant of such a system of forces.

**Solution.** The system of given forces is shown in Fig 1.24.

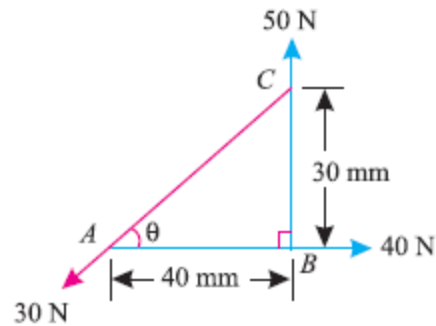

Fig 1.24

From the geometry of the figure, we find that the triangle ABC is a right-angled triangle, in which side AC = 50 mm.

Therefore

$$\sin\theta = \frac{30}{50} = 0.6$$

$$\cos\theta = \frac{40}{50} = 0.8$$

Resolving all the forces horizontally (i.e., along AB),

$$\begin{aligned} \sum H &= 40 - 30 \cos \theta \\ &= 40 - (30 \times 0.8) = 16 \text{ N} \end{aligned}$$

and now resolving all the forces vertically (i.e., along BC)

$$\begin{aligned} \sum V &= 50 - 30 \sin \theta \\ &= 50 - (30 \times 0.6) = 32 \text{ N} \end{aligned}$$

We know that magnitude of the resultant force,

$$R = \sqrt{(\sum H)^2 + (\sum V)^2} = \sqrt{16^2 + 32^2} = 35.8 \text{ N} \quad \text{Ans.}$$

**Example 1.6A** system of forces are acting at the corners of a rectangular block as shown in Fig 1.25. Determine the magnitude and direction of the resultant force.

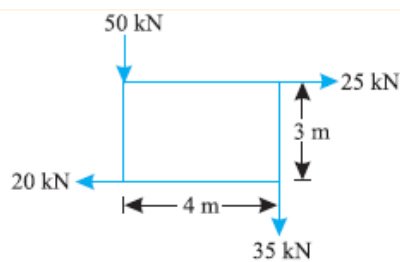

Fig 1.25

**Solution.** Given:

Let  $\theta$  = Angle which the resultant force makes with the horizontal  
System of forces

**Magnitude of the resultant force**

Resolving forces horizontally,

$$\sum H = 25 - 20 = 5 \text{ kN}$$

and now resolving the forces vertically

$$\sum V = (-50) + (-35) = -85 \text{ kN}$$

$\therefore$  Magnitude of the resultant force

$$R = \sqrt{(\sum H)^2 + (\sum V)^2} = \sqrt{(5)^2 + (-85)^2} = 85.15 \text{ kN Ans.}$$

Since the side AB is along x-axis, and the side BC is along y-axis, therefore it is a right-angled triangle.

Now in triangle ABC,

$$AC = \sqrt{AB^2 + BC^2} = \sqrt{40^2 + (30)^2} = 50 \text{ m}$$

**Direction of the resultant force**

We know that

$$\tan \theta = \frac{\sum V}{\sum H} = \frac{-85}{5} = -17 \quad \text{or} \quad \theta = 86.6^\circ$$

Since  $\sum H$  is positive and  $\sum V$  is negative, therefore resultant lies between  $270^\circ$  and  $360^\circ$ .

Thus actual angle of the resultant force

$$= 360^\circ - 86.6^\circ = 273.4^\circ \text{ Ans.}$$

**Example 1.7.** The following forces act at a point :

(i) 20 N inclined at  $30^\circ$  towards North of East,

(ii) 25 N towards North,

(iii) 30 N towards North West, and

(iv) 35 N inclined at  $40^\circ$  towards South of West.

Find the magnitude and direction of the resultant force.

**Solution.** The system of given forces is shown in Fig 1.26

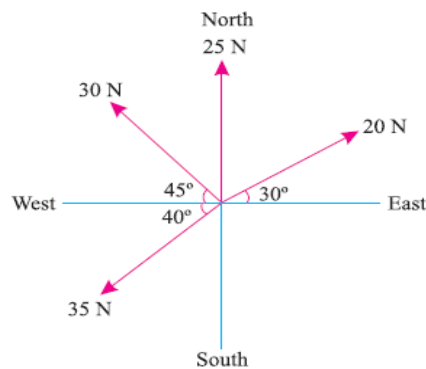

Fig. 1.26

### Magnitude of the resultant force

Resolving all the forces horizontally *i.e.*, along East-West line,

$$\begin{aligned}\Sigma H &= 20 \cos 30^\circ + 25 \cos 90^\circ + 30 \cos 135^\circ + 35 \cos 220^\circ \text{ N} \\ &= (20 \times 0.866) + (25 \times 0) + 30 (-0.707) + 35 (-0.766) \text{ N} \\ &= -30.7 \text{ N} \dots(i)\end{aligned}$$

and now resolving all the forces vertically *i.e.*, along North-South line,

$$\begin{aligned}\Sigma V &= 20 \sin 30^\circ + 25 \sin 90^\circ + 30 \sin 135^\circ + 35 \sin 220^\circ \text{ N} \\ &= (20 \times 0.5) + (25 \times 1.0) + (30 \times 0.707) + 35 (-0.6428) \text{ N} \\ &= 33.7 \text{ N} \dots(ii)\end{aligned}$$

We know that magnitude of the resultant force,

$$R = \sqrt{(\Sigma H)^2 + (\Sigma V)^2} = \sqrt{(-30.7)^2 + (33.7)^2} = 45.6 \text{ N Ans.}$$

*Direction of the resultant force*

Let  $\theta$  = Angle, which the resultant force makes with the East.

We know that,

$$\tan \theta = \Sigma V / \Sigma H = 33.7 / -30.7 = -1.098 \quad \text{or} \quad \theta = 47.7^\circ$$

Since  $\Sigma H$  is negative and  $\Sigma V$  is positive, therefore resultant lies between  $90^\circ$  and  $180^\circ$ . Thus actual angle of the resultant =  $180^\circ - 47.7^\circ = 132.3^\circ$  **Ans.**

**Example 1.8** Forces  $3$ ,  $12\sqrt{2}$  and  $3\sqrt{2}$  kN act at a point towards the East, North-East, and South-West respectively. Determine the resultant of the given forces.

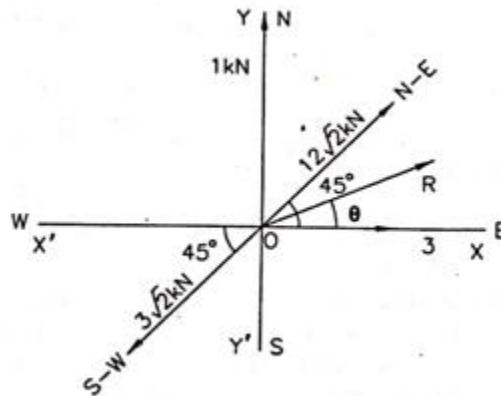

Fig. 1.27

Let

$\Sigma F_x$  = algebraic sum of the resolved parts of the forces along X-axis, and

$\Sigma F_y$  = algebraic sum of the resolved parts of the forces along Y-axis.

$$\begin{aligned}\Sigma F_x &= 3 \cos 0^\circ + 12\sqrt{2} \cos 45^\circ - 3\sqrt{2} \cos 45^\circ \\ &= 12 \text{ kN}\end{aligned}$$

$$\begin{aligned}\Sigma F_y &= 3 \sin 0^\circ + 12\sqrt{2} \sin 45^\circ - 3\sqrt{2} \sin 45^\circ \\ &= 9 \text{ kN}\end{aligned}$$

$$R = \sqrt{(\Sigma F_x)^2 + (\Sigma F_y)^2} = 15 \text{ kN}$$

Let,

R required resultant of the given forces making an angle  $\alpha$  with x-axis

$$\tan \alpha = \frac{\sum F_y}{\sum F_x} \Rightarrow \alpha = 36.90^\circ$$

### 1.4.2 GRAPHICAL METHOD

#### TRIANGLE LAW OF FORCES

*It states,* “If two forces acting simultaneously on a particle be represented in magnitude and direction by the two sides of a triangle, taken in order; their resultant may be represented in magnitude and direction by the third side of the triangle, taken in opposite order.”

**Explanation.** Let two forces P and Q acting at O be such that they can be represented in magnitude and direction by the sides AB and BC of the triangle ABC. Then, according to the theorem of triangle of forces, their resultant R will be represented in magnitude and direction by AC which is the third side of the triangle ABC taken in the reverse order of CA.

**Proof.**

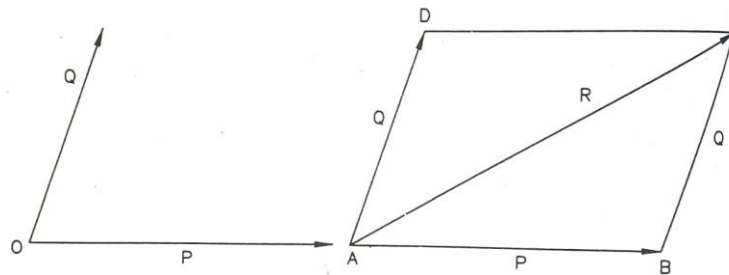

Fig. 1.28

In Fig.1.28 The parallelogram ABCD is completed with sides AB and BC of the triangle ABC. Side AD is equal and parallel to BC. So, force Q is also represented in magnitude and direction by AD. Now, the resultant of P (represented by AB) and Q (represented by AD) is represented in magnitude and direction by the diagonal AC of the parallelogram ABCD. Thus, the resultant of P and Q is represented in magnitude and direction by the third side AC of the triangle ABC taken in the reverse order.

#### POLYGON LAW OF FORCES

It is an extension of Triangle Law of Forces for more than two forces, which states, “If a number of forces acting simultaneously on a particle, be represented in magnitude and direction, by the sides of a polygon taken in order then the resultant of all these forces may be represented, in magnitude and direction, by the closing side of the polygon, taken in opposite order.”

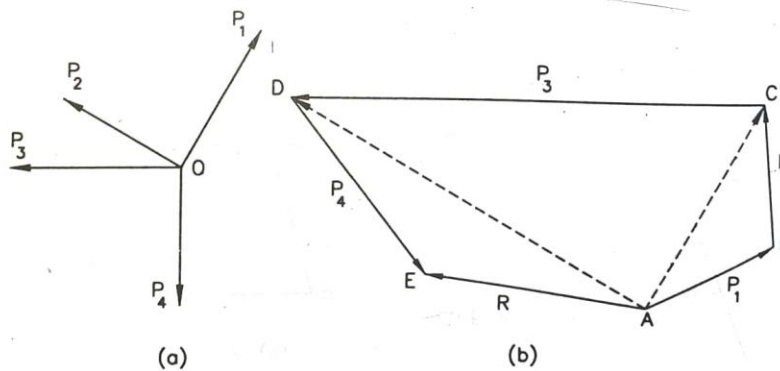

Fig. 1.29

**Proof.**

Let forces  $P_1, P_2, P_3$  and  $P_4$ , acting at a point O be such that they can be represented in magnitude and direction by the sides AB, BC, CD and DE of a polygon ABCDE as shown in fig. 1.29.

We are to prove that the resultant of these forces is represented in magnitude and direction by the side AE in the direction from A towards E.

According to the triangle law of forces, AC represents the resultant  $R_1$  of  $P_1$  and  $P_2$ , AD represents the resultant  $R_2$  of  $R_1$  and  $P_3$ . Thus, AD represents the resultant of  $P_1, P_2$  and  $P_3$ .

According to the same law, AE represents the resultant  $R_3$  of  $R_2$  and  $P_4$ . Thus, AE represents the resultant of  $P_1, P_2, P_3$  and  $P_4$ .

**GRAPHICAL CONDITIONS OF EQUILIBRIUM OF A SYSTEM OF CO-PLANAR CONCURRENT FORCES**

The end point of the vector diagram must coincide with the starting point of the diagram. Hence the vector diagram must be a closed figure.

So, graphical condition of equilibrium of a system of co-planar concurrent forces may be stated as follows:

If a system of co-planar concurrent forces be in equilibrium, the vector diagram drawn with the given forces taken in order must be a closed figure.

**SPACE DIAGRAM, VECTOR DIAGRAM AND BOW'S NOTATION**

**Graphical Representation of a Force:**

A force can be represented graphically by drawing a straight line to a suitable scale and parallel to the line of action of the given force and an arrowhead indicates the direction.

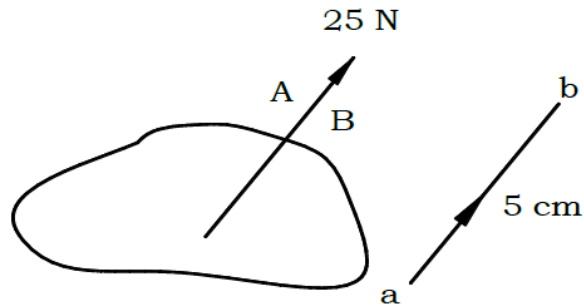

Fig. 1.30

A force in the figure is represented by a vector of length 5 cm (scale 1 cm = 5 N) by drawing a line parallel to the given force and arrowhead indicates the direction of the force.

### Space diagram

Space diagram is that diagram which shows the forces in space. In a space diagram the actual directions of forces are marked by straight lines with arrow put on their head to indicate the sense in which the forces act. Following Fig. shows the space diagram of forces  $P_1, P_2, P_3$

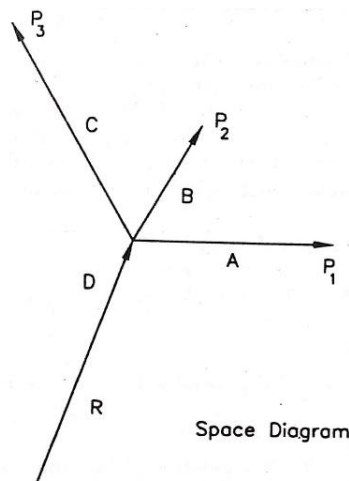

Fig. 1.31

**Vector diagram** is a diagram which is drawn according to some suitable scale to represent the given forces in magnitude, direction and sense. The resultant of the given forces is represented by the closing line of the diagram and its sense is from the starting point towards the end point  $d$  as shown in Fig 1.32.



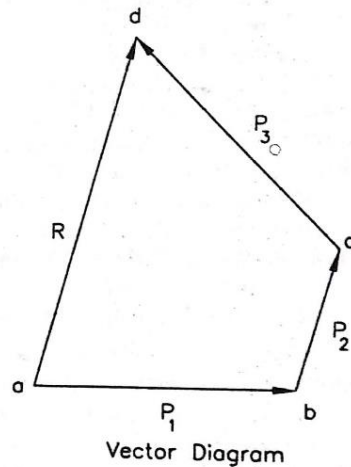

Fig 1.32

**Bow's notation** is a method of designating forces in space diagram. According to this system of notation, each force in space diagram is denoted by two capital letters, each being placed on two sides of the line of action of the force. In Fig.1.32, forces  $P_1$ ,  $P_2$  and  $P_3$  are denoted by  $AB$ ,  $BC$  and  $CD$  respectively. In the vector diagram, the corresponding forces are represented by  $ab$ ,  $bc$  and  $cd$  respectively. Bow's notation is particularly suitable in graphical solution of systems of forces which are in equilibrium.

**Example 1.9** A particle is acted upon by three forces equal to 50 N, 100 N and 130 N, along the three sides of an equilateral triangle, taken in order. Find graphically the magnitude and direction of the resultant force.

**Solution.** The system of given forces is shown in Fig. First of all, name the forces according to Bow's notations as shown in Fig.1.33 a. The 50 N force is named as  $AD$ , 100 N force as  $BD$  and 130 N force as  $CD$

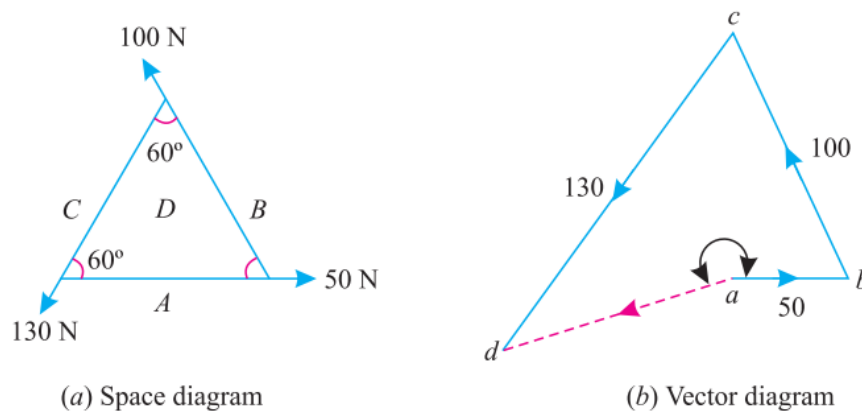

Fig 1.33

Now draw the vector diagram for the given system of forces as shown in Fig 1.33.(b) and as discussed below :

1. Select some suitable point  $a$  and draw  $ab$  equal to 50 N to some suitable scale and parallel to the 50 N force of the space diagram.
2. Through  $b$ , draw  $bc$  equal to 100 N to the scale and parallel to the 100 N force of the space diagram.
3. Similarly through  $c$ , draw  $cd$  equal to 130 N to the scale and parallel to the 130 N force of the space diagram.
4. Join  $ad$ , which gives the magnitude as well as direction of the resultant force.
5. By measurement, we find the magnitude of the resultant force is equal to 70 N and acting at an angle of  $200^\circ$  with  $ab$ . **Ans.**

### CLASSIFICATION OF PARALLEL FORCES

The parallel forces may be, broadly, classified into the following two categories, depending upon their directions:

1. Like parallel forces.
2. unlike parallel forces.

#### LIKE PARALLEL FORCES

The forces, whose lines of action are parallel to each other and all of them act in the same direction as shown in Fig. 1.34 (a) are known as like parallel forces

#### UNLIKE PARALLEL FORCES

The forces, whose lines of action are parallel to each other and all of them do not act in the same direction as shown in Fig.1.34 (b) are known as unlike parallel forces.

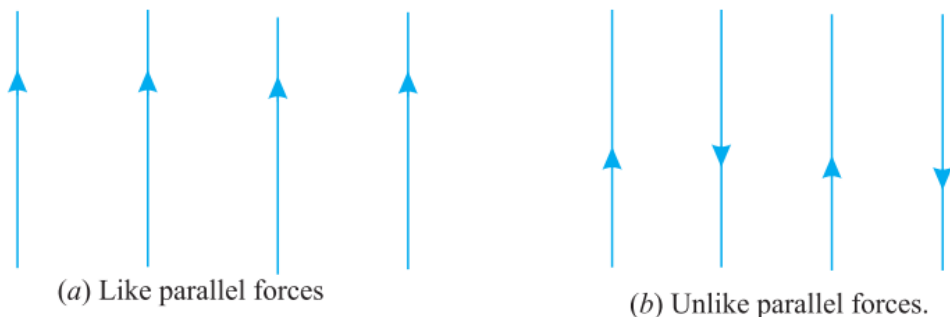

Fig 1.34

The magnitude and position of the resultant force, of a given system of parallel forces (like or unlike) may be found out analytically or graphically

### 1.4.3 ANALYTICAL METHOD OF DETERMINATION OF THE RESULTANT OF A SYSTEM OF LIKE AND UNLIKE PARALLEL FORCES

In this method, the sum of clockwise moments is equated with the sum of anticlockwise moments about a point.

#### ANALYTICAL METHOD OF DETERMINING THE POINT OF APPLICATION OF THE RESULTANT OF A SYSTEM OF LIKE AND UNLIKE NON CONCURRENT PARALLEL FORCES

We know that the algebraic sum of the moments of any number of co-planar forces (concurrent or non-concurrent) about any point in their plane is equal to the moment of their resultant about the same point. This principle is applied in determining the point of application of the resultant of any number of parallel forces.

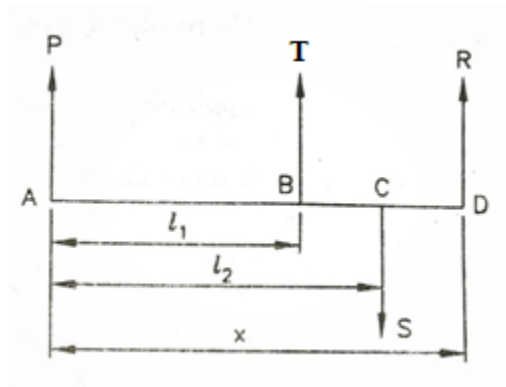

Fig 1.35

Let parallel forces P, T and S be acting at the points A, B and C respectively as shown in Fig 1.35.

The resultant of the parallel forces is given by  $R = P + T - S$ .

Let  $x$  = required distance of the point of application of R from A

i.e.  $x = AD$ .

Taking moments about A, we get

$$R \times x - Sx l_2 + Tx l_1 = 0$$

$$R \times x = Sx l_2 - Tx l_1$$

$$x = \frac{S \times l_2 - T \times l_1}{R} = \frac{S \times l_2 - T \times l_1}{P + Q - S}$$

**EXAMPLE 1.10A** beam 3 m long weighing 400 N is suspended in a horizontal position by two vertical strings, each of which can withstand a maximum tension of 350 N only. How far a body of 200 N weight be placed on the beam, so that one of the strings may just break ?

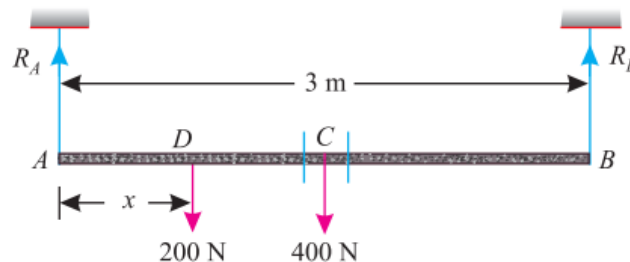

Fig 1.36

Let  $x$  = Distance between the body of weight 200 N and support A.

We know that one of the string (say A) will just break, when the tension will be 350 N. (i.e.,  $R_A = 350$  N).

Now taking clockwise and anticlockwise moments about B and equating the same,

$$350 \times 3 = 200(3 - x) + 400 \times 1.5$$

$$1050 = 600 - 200x + 600 = 1200 - 200x$$

$$200x = 1200 - 1050 = 150$$

$$x = \frac{150}{200} = 0.75m$$

**Example 1.11.** Two unlike parallel forces of magnitude 400 N and 100 N are acting in such away that their lines of action are 150 mm apart. Determine the magnitude of the resultant force and the point at which it acts.

**Solution.** Given : The system of given force is shown in Fig

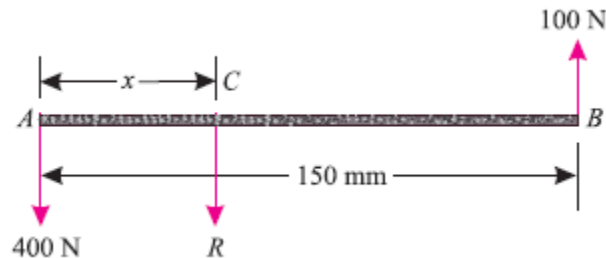

Fig 1.37

Magnitude of the resultant force

Since the given forces are unlike and parallel, therefore magnitude of the resultant force,

$$R = 400 - 100 = 300 \text{ N Ans.}$$

Point where the resultant force acts

Let  $x$  = Distance between the lines of action of the resultant force and  $A$  in mm.

Now taking clockwise and anticlockwise moments about  $A$  and equating the same,

$$300 \times x = 100 \times 150 = 15\,000$$

$$x = 15000/300 = 50\text{mm ans.}$$

### GRAPHICAL METHOD FOR THE RESULTANT OF PARALLEL FORCES

Consider a number of parallel forces (say three like parallel forces)  $P_1$ ,  $P_2$  and  $P_3$  whose resultant is required to be found out as shown in Fig 1.38.a

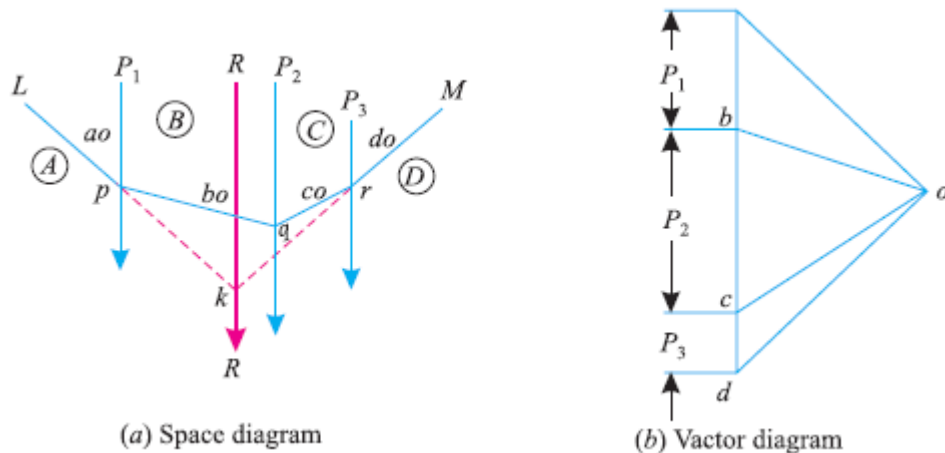

Fig 1.38

First of all, draw the space diagram of the given system of forces and name them according to Bow's notations as shown in Fig.1.38 (a). Now draw the vector diagram for the given forces as shown in Fig.1.38 (b) and as discussed below :

1. Select some suitable point  $a$ , and draw  $ab$  equal to the force  $AB$  ( $P_1$ ) and parallel to it to some suitable scale.
2. Similarly draw  $bc$  and  $cd$  equal to and parallel to the forces  $BC$  ( $P_2$ ) and  $CD$  ( $P_3$ ) respectively.
3. Now take some convenient point  $o$  and joint  $oa$ ,  $ob$ ,  $oc$  and  $od$ .
4. Select some point  $p$ , on the line of action of the force  $AB$  of the space diagram and through it draw a line  $Lp$  parallel to  $ao$ . Now through  $p$  draw  $pq$  parallel to  $bo$  meeting the line of action of the force  $BC$  at  $q$ .
5. Similarly draw  $qr$  and  $rM$  parallel to  $co$  and  $do$  respectively.
6. Now extend  $Lp$  and  $Mr$  to meet at  $k$ . Through  $k$ , draw a line parallel to  $ad$ , which gives the required position of the resultant force.
7. The magnitude of the resultant force is given by  $ad$  to the scale.

**Note.** This method for the position of the resultant force may also be used for any system of forces i.e. parallel, like, unlike or even inclined.

## 1.5 MOMENT OF A FORCE

It is the turning effect produced by a force, on the body, on which it acts. The moment of a force is equal to the product of the force and the perpendicular distance of the point, about which the moment is required and the line of action of the force.

Mathematically, moment,

$$M = P \times l$$

where  $P$  = Force acting on the body,

and  $l$  = Perpendicular distance between the point, about which the moment is required and the line of action of the force.

Moment of a force about a point is the product of the force and the perpendicular distance of the point from the line of action of the force.

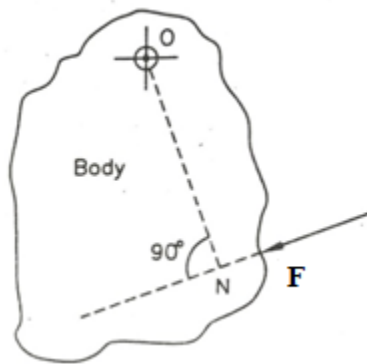

Fig 1.39

Let a force  $P$  act on a body which is hinged at  $O$ .

Then, moment of  $P$  about the point  $O$  in the body is  $= F \times ON$ ,

where  $ON$  = perpendicular distance of  $O$  from the line of action of the force  $F$ .

### MOMENT OF A FORCE ABOUT AN AXIS

Let us consider a door leaf hinged to a vertical wall by several hinges. Let us consider a vertical axis  $XY$  passing through hinges as shown in Fig 1.40.

Let a force  $F$  be applied to the door leaf at right angles to its plane and at a perpendicular distance of  $l$  from the  $XY$ -axis. Then, moment of the force  $F$  about  $XY$ -axis  $= F \times l$ .

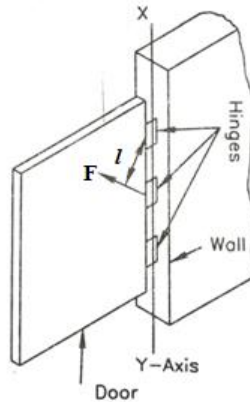

Fig 1.40

## UNIT OF MOMENT

Unit of moment depends upon unit of force and unit of length.

If, however, force is measured in Newton and distance is measured in meter, the unit of moment will be Newton meter (Nm). If force is measured in kilo Newton and distance is measured in meter, unit of moment will be kilo Newton meter (kNm) and so on. Unit of moment is the same as that of work. But work is completely different from moment.

## TYPES OF MOMENTS

Broadly speaking, the moments are of the following two types:

1. Clockwise moments.
2. Anticlockwise moments.

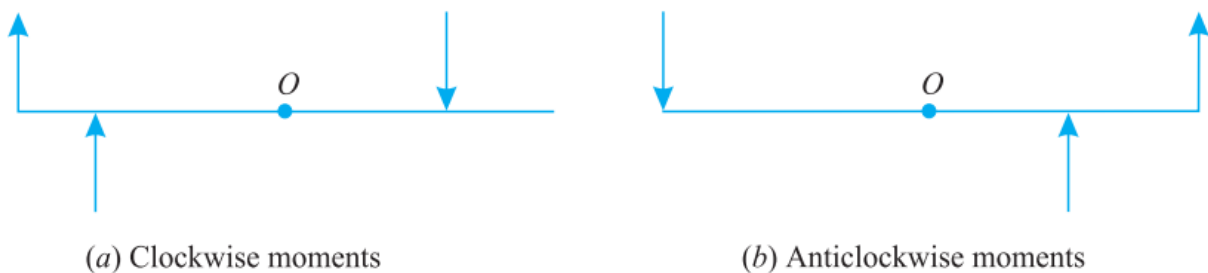

Fig 1.41

**Clockwise moment** is the moment of a force, whose effect is to turn or rotate the body, about the point in the same direction in which hands of a clock move as shown in Fig. 1.41(a) .

**Anticlockwise moment** is the moment of a force, whose effect is to turn or rotate the body, about the point in the opposite direction in which the hands of a clock move as shown in Fig1.41 (b).

### POSITIVE MOMENT AND NEGATIVE MOMENT

It is found that some moments acting on a body have a tendency to turn the body in the clockwise direction and some other moments acting 'on the same body have a tendency to turn the body in the anti-clockwise or counter clockwise direction.

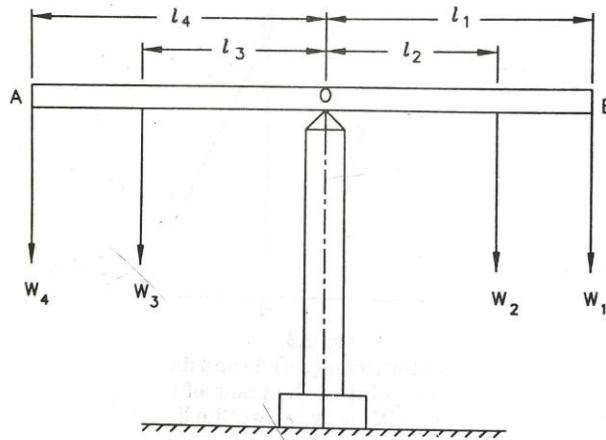

Fig 1.42

In order to distinguish turning tendency in the clockwise direction from that in the anti-clockwise direction, it has become necessary to treat moment in one direction as positive and moment in the reverse direction as negative. Usually, anti-clockwise moment is taken as positive moment and clockwise moment is taken as negative moment. But there is no hard and fast rule regarding sign convention of moments.

### ALGEBRAIC SUM OF THE MOMENTS

With reference to Fig1.42, a bar AB is held in position on a pivot O under the action of four loads  $W_1$ ,  $W_2$ ,  $W_3$  and  $W_4$ , whose lines of action are at perpendicular distances of  $l_1$ ,  $l_2$ ,  $l_3$ ,  $l_4$  respectively from O. Then, moment of about O =  $W_1 \times l_1$ . This moment has a tendency to turn the bar about O in a vertical plane in the clockwise direction. The moment due to  $W_2$  about O =  $W_2 \times l_2$ . This moment also has a tendency to turn the bar AB in the clockwise direction in a vertical plane about O.

The moment due to  $W_3$  about O =  $W_3 \times l_3$ . This moment has a tendency to turn the bar AB in the anti-clockwise direction in a vertical plane about O. The moment due to  $W_4$ , about O =  $W_4 \times l_4$ . This moment also has a tendency to turn the bar AB in the anti-clockwise direction in the vertical plane about O.



Algebraic sum means summation considering proper signs of the physical quantities. Hence, algebraic sum of the moments of  $W_1, W_2, W_3, W_4$  about  $O = W_3 \times l_3 + W_4 \times l_4 - W_1 \times l_1 - W_2 \times l_2$

### GEOMETRICAL REPRESENTATION OF THE MOMENT OF THE FORCE ABOUT A POINT

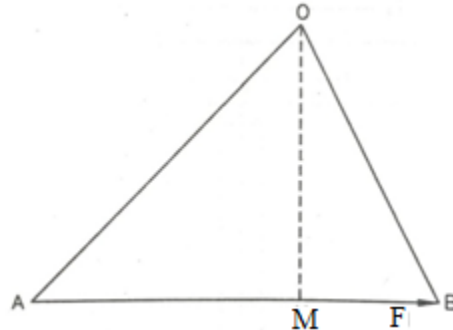

Fig 1.43

Let a force  $F$  represented in magnitude and direction by  $AB$  be acting on a body and let  $O$  be any point in the plane of the force  $F$  as shown in Fig 1.43.

From  $O$ , perpendicular  $OM$  is drawn on the line of action of  $F$ . Then, moment of  $F$  about

$$O = F \times OM = 2 \times \frac{1}{2} F \times OM = 2 \times \frac{1}{2} AB \times OM = 2 \times \text{Area of } \triangle AOB.$$

Thus, the moment of a force about a point is represented by twice the area of the triangle formed by joining the point to the extremities of the straight line which represents the force.

### VARIGNON'S THEOREM

Varignon's theorem states that the algebraic sum of the moment, two forces about any point in their plane is equal to the moment of the, resultant about the same point.

**Proof.**

**Case (i)** When the forces are concurrent

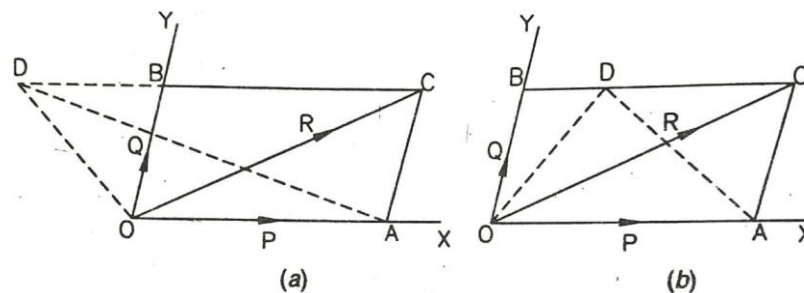

Fig 1.44

Let P and Q be any two forces acting at a point O along lines OX and OY respectively and let D be any point in their plane as shown in Fig 1.44.

Line DC is drawn parallel to OX to meet OY at B. Let in some suitable scale, line OB represent the force Q in magnitude and direction and let in the same scale, OA represent the force P in magnitude and direction.

With OA and OB as the adjacent sides, parallelogram OACB is completed and OC is joined. Let R be the resultant of forces P and Q. Then, according to the "Theorem of parallelogram of forces", R is represented in magnitude and direction by the diagonal OC of the parallelogram OACB.

The point D is joined with points O and A. The moments of P, Q and R about D are given by 2 x area of  $\Delta AOD$ , 2 x area of  $\Delta OBD$  and 2 x area of  $\Delta OCD$  respectively.

With reference to Fig1.44(a), the point D is outside the  $\angle AOB$  and the moments of P, Q and R about D are all anti-clockwise and hence these moments are treated as +ve.

Now, the algebraic sum of the moments of P and Q about

$$\begin{aligned} D &= 2\Delta AOD + 2\Delta OBD \\ &= 2(\Delta AOD + \Delta OBD) \\ &= 2(\Delta AOC + \Delta OBD) \text{ [See note below]} \\ &= 2(\Delta OBC + \Delta OBD) \\ &= 2\Delta OCD = \text{Moment of R about D.} \end{aligned}$$

[Note. As AOC and AOD are on the same base and have the same altitude.  $\Delta AOD = \Delta OBC$ . .

Again, As AOC and OBC have equal bases and equal altitudes.  $\Delta AOC = \Delta OBC$ ].

With reference to Fig 1.44 (b), the point D is within the  $\angle AOB$  and the moments of P, Q and R about D are respectively anti-clockwise, clockwise and anti-clockwise.

Now, the algebraic sum of the forces P and Q about

$$\begin{aligned} D &= 2\Delta AOD - 2\Delta OBD = 2(\Delta AOD - \Delta OBD) = 2(\Delta AOC - \Delta OBD) = 2(\Delta OBC - \Delta OBD) \\ &= 2\Delta OCD = \text{Moment of R about D} \end{aligned}$$

**Case (ii) :** When the forces are parallel

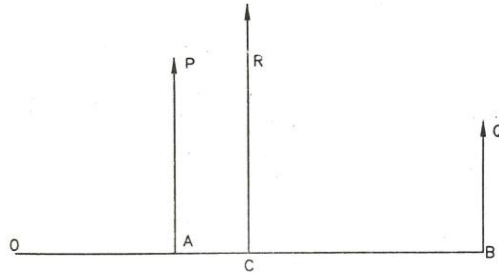

Fig 1.45

Let P and Q be any two like parallel forces (i.e. the parallel forces whose lines of action are parallel and which act in the same sense) and O be any point in their plane.

Let R be the resultant of P and Q.

Then,  $R = P + Q$

From O, line OACB is drawn perpendicular to the lines of action of forces P, Q and R intersecting them at A, B and C respectively as shown in Fig 1.45.

Now, algebraic sum of the moments of P and Q about O

$$= P \times OA + Q \times OB$$

$$= P \times (OC - AC) + Q \times (OC + BC)$$

$$= P \times OC - P \times AC + Q \times OC + Q \times BC.$$

$$\text{But } P \times AC = Q \times BC$$

Algebraic sum of the moments of P and Q about O

$$= P \times OC + Q \times OC$$

$$= (P + Q) \times OC = R \times OC = \text{Moment of R about O.}$$

In case of unlike parallel forces also it can be proved that the algebraic sum of the moments of two unlike parallel forces (i.e. the forces whose lines of action are parallel but which act in reverse senses) about any point in their plane is equal to the moment of their resultant about the same point.

## PRINCIPLE OF MOMENTS

1. If a system of co-planar forces (concurrent or non-concurrent) is in equilibrium, the algebraic sum of the moments of those forces about any point in their plane is zero, i.e., the sum of the clockwise moments about any point in their plane is equal to the sum of the anticlockwise moments about the same point.

2. The algebraic sum of the moments of any number of co-planar forces (concurrent or non-concurrent) about a point lying on the line of action of their resultant is zero.

3. From 1 and 2 above, it can be concluded that if the algebraic sum of the moments of any number of co-planar forces about any point in their plane is zero, either the forces are in equilibrium or their resultant passes through that point.

**Example 1.12A** force of 15 N is applied perpendicular to the edge of a door 0.8 m wide as shown in Fig (a). Find the moment of the force about the hinge. If this force is applied at an angle of  $60^\circ$  to the edge of the same door, as shown in Fig.1.47 (b), find the moment of this force.

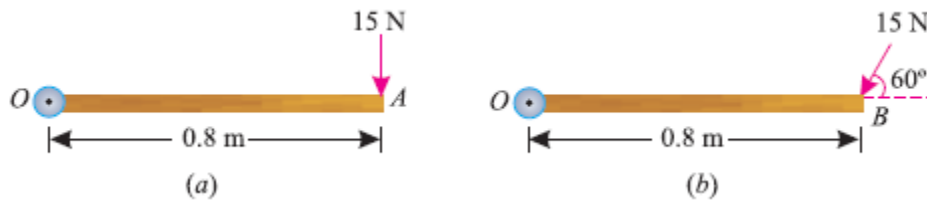

Fig 1.46

**Solution.** Given : Force applied ( $P$ ) = 15 N and width of the door ( $l$ ) = 0.8 m

Moment when the force acts perpendicular to the door  
We know that the moment of the force about the hinge,

$$= P \times l = 15 \times 0.8 = 12.0 \text{ N-m Ans.}$$

Moment when the force acts at an angle of  $60^\circ$  to the door

This part of the example may be solved either by finding out the perpendicular distance between the hinge and the line of action of the force as shown in Fig 1.47(a) or by finding out the vertical component of the force as shown in Fig 1.47.(b).

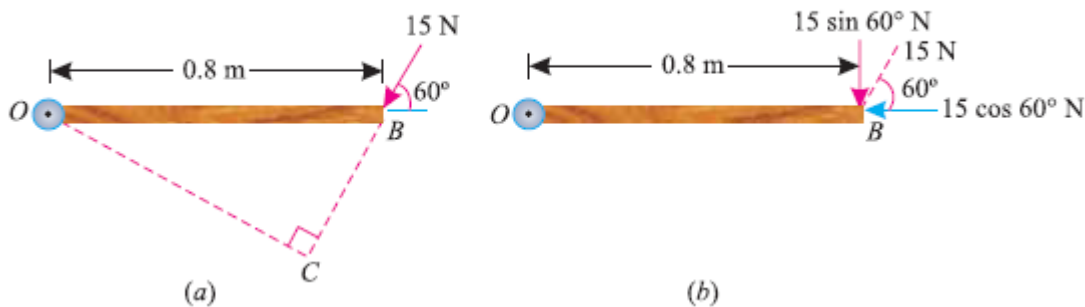

Fig 1.47

From the geometry of Fig.1.47(a), we find that the perpendicular distance between the line of action of the force and hinge,

$$OC = OB \sin 60^\circ = 0.8 \times 0.866 = 0.693 \text{ m}$$

$$\therefore \text{Moment} = 15 \times 0.693 = 10.4 \text{ N-m Ans.}$$

In the second case, we know that the vertical component of the force

$$= 15 \sin 60^\circ = 15 \times 0.866 = 13.0 \text{ N}$$

$$\therefore \text{Moment} = 13 \times 0.8 = 10.4 \text{ N-m Ans.}$$

**Note.** Since distance between the horizontal component of force ( $15 \cos 60^\circ$ ) and the hinge is zero, therefore moment of horizontal component of the force about the hinge is also zero

**Example 1.13A** uniform plank ABC of weight 30 N and 2 m long is supported at one end A and at a point B 1.4 m from A as shown in Fig. Find the maximum weight W, that can be placed at C, so that the plank does not topple.

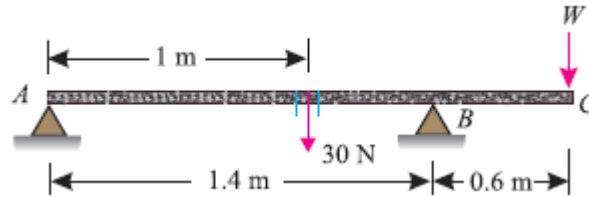

Fig 1.48

**Solution.** Weight of the plank ABC = 30 N; Length of the plank ABC = 2 m and distance between end A and a point B on the plank (AB) = 1.4 m.

We know that weight of the plank (30 N) will act at its midpoint, as it is of uniform section.

This point is at a distance of 1 m from A or 0.4 m from B as shown in the figure.

We also know that if the plank is not to topple, then the reaction at A should be zero for the maximum weight at C.

Now taking moments about B and equating the same,

$$30 \times 0.4 = W \times 0.6$$

$$W = 12/0.6 = 20\text{N ANS.}$$

**EXAMPLE 1.14** A uniform wheel of 600 mm diameter, weighing 5 kN rests against a rigid rectangular block of 150 mm height.

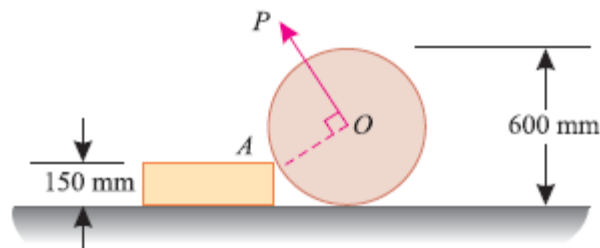

Fig 1.49

**Find the least pull, through the centre of the wheel, required just to turn the wheel over the corner A of the block. Also find the reaction on the block. Take all the surfaces to be smooth.**

**Solution.** Given : Diameter of wheel = 600 mm; Weight of wheel = 5 kN and height of the block = 150 mm.

Least pull required just to turn the wheel over the corner

Let P = Least pull required just to turn the wheel in kN.

A little consideration will show that for the least pull, it must be applied normal to AO.

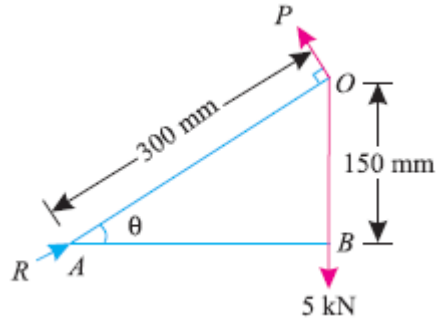

Fig 1.50

From the geometry of the figure, we find that

$$\sin\theta = \frac{150}{300} = 0.5$$

$$\Rightarrow \theta = 30^\circ$$

$$\text{and, } AB = \sqrt{(300)^2 - (150)^2} = 260 \text{ mm}$$

Now taking moments about A and equating the same,

$$P \times 300 = 5 \times 260 = 1300$$

$$\therefore P = \frac{1300}{300} = 4.33 \text{ KN}$$

#### Reaction on the block

Let, R = Reaction on the block in KN

Resolving the forces horizontally and equating the same

$$R \cos 30^\circ = P \sin 30^\circ$$

$$\therefore R = \frac{P \sin 30^\circ}{\cos 30^\circ} = \frac{4.33 \times 0.5}{0.866} = 2.5 \text{ KN}$$

The position of a resultant force may be found out by moments as discussed below:

1. First of all, find out the magnitude and direction of the resultant force by the method of resolution as discussed earlier in chapter 'Composition and Resolution of Forces'.
2. Now equate the moment of the resultant force with the algebraic sum of moments of the given system of forces about any point. This may also be found out by equating the sum of clockwise moments and that of the anticlockwise moments about the point, through which the resultant force will pass.

**EXAMPLE 1.15.** Three forces of 2P, 3P and 4P act along the three sides of an equilateral triangle of side 100 mm taken in order. Find the magnitude and position of the resultant force.

## Solution

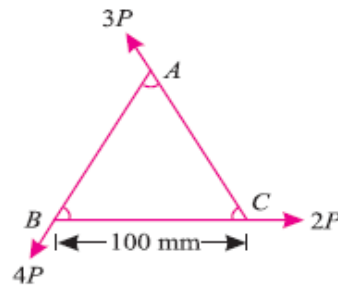

Fig 1.51

### Magnitude of the resultant force

Resolving all the forces horizontally,

$$\Sigma H = 2P + 3P \cos 120^\circ + 4P \cos 240^\circ$$

$$= 2P + 3P (-0.5) + 4P (-0.5)$$

$$= -1.5P \dots\dots(i)$$

and now resolving all the forces vertically.

$$\Sigma V = 3P \sin 60^\circ - 4P \sin 60^\circ$$

$$= (3P \times 0.866) - (4P \times 0.866)$$

$$= -0.866P \dots\dots(ii)$$

We know that magnitude of the resultant force

$$R = \sqrt{(\Sigma H)^2 + (\Sigma V)^2} = \sqrt{(-1.5P)^2 + (-0.866P)^2} = 1.732P$$

### Position of the resultant force

Let  $x$  = Perpendicular distance between B and the line of action of the resultant force.

Now taking moments of the resultant force about B and equating the same,

$$1.732P \times x = 3P \times 100 \sin 60^\circ = 3P \times (100 \times 0.866) = 259.8P$$

$$\therefore x = \frac{259.8}{1.732} = 150 \text{ mm} \text{ (The moment of the force } 2P \text{ and } 4P \text{ about the point } B \text{ will be zero, as they pass through it.)}$$

## COUPLE

A pair of two equal and unlike parallel forces (i.e. forces equal in magnitude, with lines of action parallel to each other and acting in opposite directions) is known as a couple.

As a matter of fact, a couple is unable to produce any translatory motion (i.e., motion in a straight line). But it produces a motion of rotation in the body, on which it acts. The simplest example of a couple is the forces applied to the key of a lock, while locking or unlocking it.

**ARM OF A COUPLE:** The perpendicular distance between the lines of action of the two equal and opposite parallel forces, is known as arm of the couple.

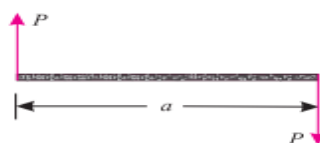

Fig 1.52

## MOMENT OF A COUPLE

The moment of a couple is the product of the force (i.e., one of the forces of the two equal and opposite parallel forces) and the arm of the couple. Mathematically:

$$\text{Moment of a couple} = P \times a$$

where  $P$  = Magnitude of the force, and  $a$  = Arm of the couple.

**CLASSIFICATION OF COUPLES** The couples may be, broadly, classified into the following two categories, depending upon their direction, in which the couple tends to rotate the body, on which it acts: 1. Clockwise couple, and 2. Anticlockwise couple.

**CLOCKWISE COUPLE:** A couple, whose tendency is to rotate the body, on which it acts, in a clockwise direction, is known as a clockwise couple as shown in Fig. 1.53 (a). Such a couple is also called positive couple.

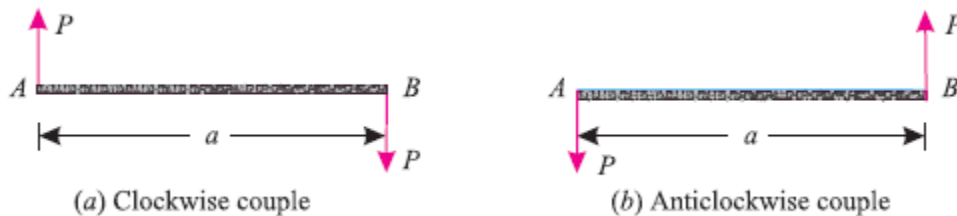

Fig 1.53

**ANTICLOCKWISE COUPLE:** A couple, whose tendency is to rotate the body, on which it acts, in an anticlockwise direction, is known as an anticlockwise couple as shown in Fig 1.53(b). Such a couple is also called a negative couple.

### UNITS OF COUPLE:

The SI unit of couple will be Newton-meter (briefly written as N-m). Similarly, the units of couple may also be kN-m (i.e.  $\text{kN} \times \text{m}$ ), N-mm (i.e.  $\text{N} \times \text{mm}$ ) etc.

**CHARACTERISTICS OF A COUPLE:** A couple (whether clockwise or anticlockwise) has the following characteristics:

1. The algebraic sum of the forces, constituting the couple, is zero.
2. The algebraic sum of the moments of the forces, constituting the couple, about any point is the same, and equal to the moment of the couple itself.
3. A couple cannot be balanced by a single force. But it can be balanced only by a couple of opposite sense.
4. Any no. of coplanar couples can be reduced to a single couple, whose magnitude will be equal to the algebraic sum of the moments of all the couples.



## EXERCISES

1. Define the term 'force', and state clearly the effects of force.
2. What are the various characteristics of a force?
3. Distinguish clearly between resolution of forces and composition of forces.
4. What are the methods for finding out the resultant force for a given system of forces?
5. State and prove parallelogram law of forces.
6. State triangle law of forces and polygon law of forces.
7. Show that the algebraic sum of the resolved part of a number of forces in a given direction, is equal to the resolved part of their resultant in the same direction.
8. Explain clearly the procedure for finding out the resultant force analytically as well as graphically.
9. What is meant by moment of a force? How will you explain it mathematically?
10. How will you represent the moment of a force geometrically?
11. Explain clearly the difference between clockwise moments and anticlockwise moments.
12. State clearly the law of moments.
13. State the Varignon's principle of moments.
14. What do you understand by the term 'parallel forces'? Discuss their classifications.
15. Distinguish clearly between like forces and unlike forces.
16. What is a couple? What is the arm of a couple and its moment?
17. Discuss the classification of couples and explain clearly the difference between a positive couple and a negative couple.
18. State the characteristics of a couple.
19. The forces 20 N, 30 N, 40 N, 50 N and 60 N are acting at one of the angular points of a regular hexagon, towards the other five angular points, taken in order. Find the magnitude and direction of the resultant force. **Ans. 155.8 N,  $\theta = 76.6^\circ$**
20. A horizontal line PQRS is 12 m long, where PQ = QR = RS = 4 m. Forces of 1000 N, 1500 N, 1000 N and 500 N act at P, Q, R and S respectively with downward direction. The lines of action of these forces make angles of  $90^\circ$ ,  $60^\circ$ ,  $45^\circ$  and  $30^\circ$  respectively with PS. Find the magnitude, direction and position of the resultant force. **Ans. 3765 N,  $\theta = 59.8^\circ$**
21. The following forces act at a point :
  - (i) 20 N inclined at  $30^\circ$  towards North of East.
  - (ii) 25 N towards North.
  - (iii) 30 N towards North West and
  - (iv) 35 N inclined at  $40^\circ$  towards South of West.
 Find the magnitude and direction of the resultant force. **Ans. 45.6 N,  $132^\circ$**
22. Two like parallel forces of 50 N and 100 N act at the ends of a rod 360 mm long. Find the magnitude of the resultant force and the point where it acts. **Ans. 240 mm**
23. A uniform beam AB of weight 100 N and 6 m long had two bodies of weights 60 N and 80 N suspended from its two ends as shown in Fig. Find analytically at what point the beam should be supported, so that it may rest horizontally. **Ans. 2.75 m**

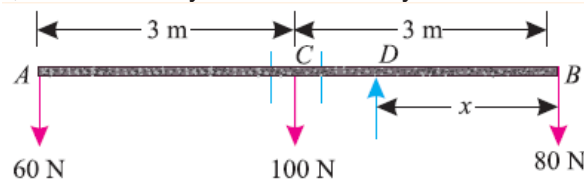

24. Find graphically the resultant of the forces shown in Fig. The distances between the forces are in mm. Also find the point, where the resultant acts.

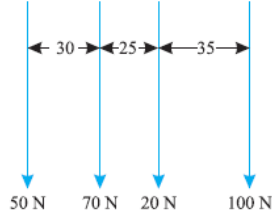

25. Find graphically the resultant of the forces shown in Fig. Also find the point where the resultant force acts.

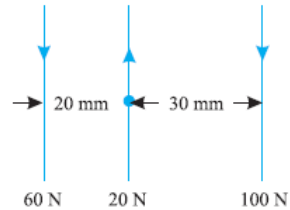

26. A rod AB 2.5 m long is supported at A and B. The rod is carrying a point load of 5 kN at a distance of 1 m from A. What are the reactions at A and B ? **[Ans. 2 kN ; 3 kN]**
27. Two halves of a round homogeneous cylinder are held together by a thread wrapped round the cylinder with two weights each equal to  $P$  attached to its ends as shown in Fig. The complete cylinder weighs  $W$  Newton. The plane of contact, of both of its halves, is vertical. Determine the minimum value of  $P$ , for which both halves of the cylinder will be in equilibrium on a horizontal plane. **Ans.  $P = 2W/3\pi$**

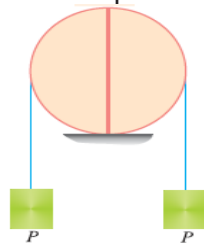

28. Four forces equal to  $P$ ,  $2P$ ,  $3P$  and  $4P$  are respectively acting along the four sides of square ABCD taken in order. Find the magnitude, direction and position of the resultant force. **Ans.  $2\sqrt{2}P$ ,  $\theta = 45^\circ$ ,  $5a/2\sqrt{2}$**

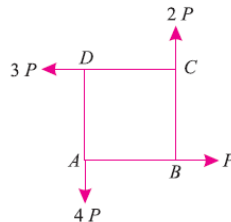

## CHAPTER 2: EQUILIBRIUM OF FORCES

### LEARNING OUTCOMES:

On completion of the subject, the student will be able to:

- Understand the concept of equilibrium
- Understand and analyse the various analytical and graphical conditions required for equilibrium
- Understand the concept of free body diagram
- Understand the concept of Lami's theorem
- Solve problems using free body diagram and Lami's theorem.

### 2.1 DEFINITION

A little consideration will show, that if the resultant of a number of forces, acting on a particle is zero, the particle will be in equilibrium. Such a set of forces, whose resultant is zero, are called equilibrium forces..

A body can be said to be in **equilibrium** when all the force acting on a body balance each other or in other word there is no net force acting on the body.

Equilibrium of a body is a state in which all the forces acting on the body are balanced (cancelled out), and the net force acting on the body is zero.

$$\text{i.e } \Sigma F = 0$$

### PRINCIPLES OF EQUILIBRIUM

1. Two force principle. As per this principle, if a body in equilibrium is acted upon by two forces, then they must be equal, opposite and collinear.
2. Three force principle. As per this principle, if a body in equilibrium is acted upon by three forces, then the resultant of any two forces must be equal, opposite and collinear with the third force.
3. Four force principle. As per this principle, if a body in equilibrium is acted upon by four forces, then the resultant of any two forces must be equal, opposite and collinear with the resultant of the other two forces.

### ANALYTICAL CONDITIONS OF EQUILIBRIUM OF A CO-PLANAR SYSTEM OF CONCURRENT FORCES

We know that the resultant of a system of co-planar concurrent forces is given by

$R = \sqrt{(\Sigma X)^2 + (\Sigma Y)^2}$ , where  $\Sigma X (= \Sigma H)$  = algebraic sum of the resolved parts of the forces along a horizontal direction, and  $\Sigma Y (= \Sigma V)$  = algebraic sum of the resolved parts of the forces along a vertical direction

$$\text{Or, } R^2 = (\Sigma X)^2 + (\Sigma Y)^2$$

If the forces are in equilibrium,  $R = 0 \Rightarrow 0 = (\Sigma X)^2 + (\Sigma Y)^2$

Sum of the squares of two quantities is zero when each quantity is separately equal to zero.

i.e.  $\Sigma X = 0$  ,  $\Sigma Y = 0$

Hence necessary and sufficient conditions of a system of, co-planar concurrent forces are:

1. The algebraic sum of the resolved parts of the forces in some assigned direction is equal to zero, and

2. The algebraic sum of the resolved parts of the forces in a direction at right angles to the assigned direction is equal to zero.

### **ANALYTICAL CONDITIONS OF EQUILIBRIUM OF A SYSTEM OF COPLANAR NON-CONCURRENT FORCES**

If  $R$  = resultant of a system of co-planar non-concurrent forces,

$\Sigma X$  = algebraic sum of the resolved parts of those forces along any direction, and

$\Sigma Y$  = algebraic sum of the resolved parts of those forces along a direction at right angles to the previous direction.

Then,  $R = \sqrt{(\Sigma X)^2 + (\Sigma Y)^2}$

$$R^2 = (\Sigma X)^2 + (\Sigma Y)^2$$

If the force system is in equilibrium,  $R = 0$ .

$$0 = R^2 = (\Sigma X)^2 + (\Sigma Y)^2$$

$$\Sigma X = 0, \Sigma Y = 0$$

(If sum of the squares of two digits is zero, then each digit is zero)

Thus, the necessary and sufficient conditions of equilibrium for a system of co-planar and non-concurrent forces are:

- (i) The algebraic sum of the resolved parts of the forces along any direction is equal to zero (i.e.,  $\Sigma X = 0$ ),
- (ii) The algebraic sum of the resolved parts of the forces along a directional right angles to the previous direction is equal to zero (i.e.  $\Sigma Y = 0$ ), and
- (iii) The algebraic sum of the moments of the forces about any point in their plane is equal to zero (i.e.  $\Sigma M = 0$ ).

### **TYPES OF EQUILIBRIUM**

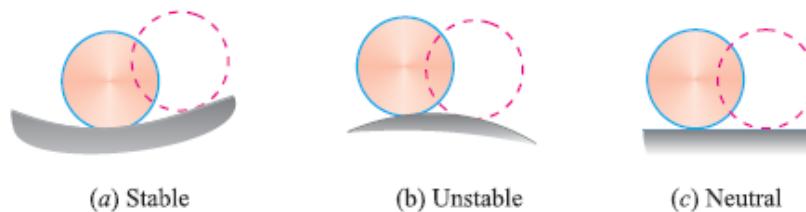

Fig 2.1

### Stable equilibrium

A body is said to be in stable equilibrium, if it returns back to its original position, after it is slightly displaced from its position of rest. This happens when some additional force sets up due to displacement and brings the body back to its original position.

### Unstable equilibrium

A body is said to be in an unstable equilibrium, if it does not return back to its original position, and heels farther away, after slightly displaced from its position of rest.

### Neutral equilibrium

A body is said to be in a neutral equilibrium, if it occupies a new position (and remains at rest in this position) after slightly displaced from its position of rest.

Free body: A body is said to be free body if it is isolated from all other connected members

### FREE BODY DIAGRAM

Free body diagram of a body is the diagram drawn by showing all the external forces and reactions on the body and by removing the contact surfaces.

Steps to be followed in drawing a free body diagram

- Isolate the body from all other bodies.
- Indicate the external forces on the free body. (The weight of the body should also be included. It should be applied at the centre of gravity of the body)
- The magnitude and direction of the known external forces should be mentioned.
- The reactions exerted by the supports on the body should be clearly indicated.
- Clearly mark the dimensions in the free body diagram.

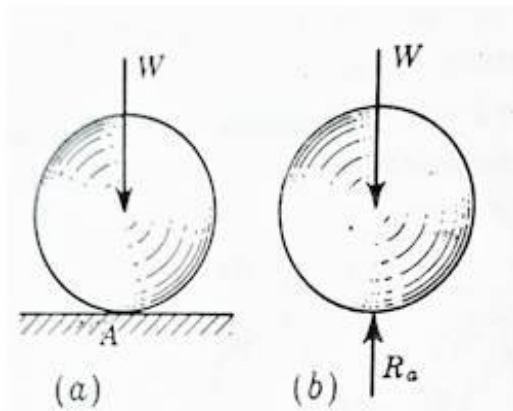

Fig 2.2

A spherical ball is rested upon a surface as shown in figure 2.2 (a). By following the necessary steps we can draw the free body diagram for this force system as shown in figure 2.2(b). Similarly fig 2.3 (b) represents free body diagram for the the force system shown in figure 2.3(a).

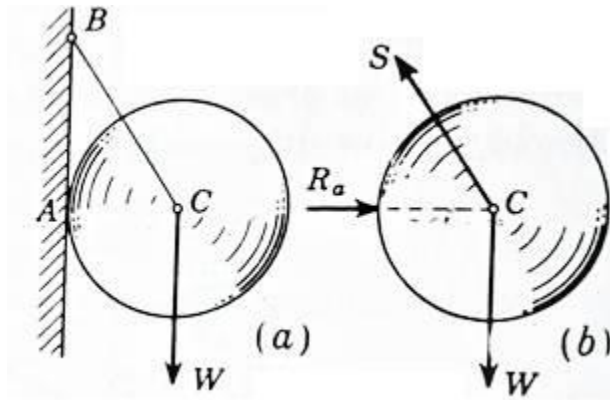

Fig 2.3

**METHOD OF EQUILIBRIUM OF COPLANAR FORCES** The methods of finding out equilibrium for concurrent and non-concurrent forces in a coplanar force system are:

- Analytical method
- Graphical method

**ANALYTICAL METHOD:**

The equilibrium of coplanar concurrent and non-concurrent forces can be studied analytically by **Lami's theorem**.

**2.2 LAMI'S THEOREM**

It states, "If three coplanar forces acting at a point be in equilibrium, then each force is proportional to the sine of the angle between the other two." Mathematically,

$$\frac{P}{\sin \alpha} = \frac{Q}{\sin \beta} = \frac{R}{\sin \gamma}$$

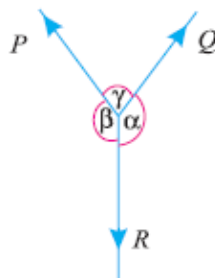

Fig 2.4

Where, *P*, *Q*, and *R* are three forces and  $\alpha$ ,  $\beta$ ,  $\gamma$  are the angles as shown in Fig.

**Proof:**

Consider three coplanar forces *P*, *Q*, and *R* acting at a point *O*. Let the opposite angles to three forces be  $\alpha$ ,  $\beta$  and  $\gamma$  as shown in Fig.

Now let us complete the parallelogram  $OACB$  with  $OA$  and  $OB$  as adjacent sides as shown in the figure. We know that the resultant of two forces  $P$  and  $Q$  will be given by the diagonal  $OC$  both in magnitude and direction of the parallelogram  $OACB$ .

Since these forces are in equilibrium, therefore the resultant of the forces  $P$  and  $Q$  must be in line with  $OD$  and equal to  $R$ , but in opposite direction

From the geometry of the figure, we find

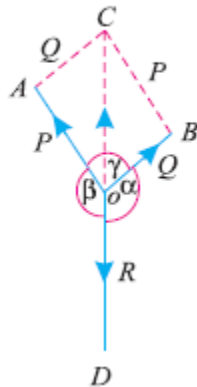

Fig 2.5

$$BC = P \text{ and } AC = Q$$

$$\therefore \angle AOC = (180^\circ - \beta)$$

$$\text{and } \angle ACO = \angle BOC = (180^\circ - \alpha)$$

$$\therefore \angle CAO = 180^\circ - (\angle AOC + \angle ACO)$$

$$= 180^\circ - [(180^\circ - \beta) + (180^\circ - \alpha)]$$

$$= 180^\circ - 180^\circ + \beta - 180^\circ + \alpha = \alpha + \beta - 180^\circ$$

$$\text{But } \alpha + \beta + \gamma = 360^\circ$$

Subtracting  $180^\circ$  from both sides of the above equation,

$$(\alpha + \beta - 180^\circ) + \gamma = 360^\circ - 180^\circ = 180^\circ$$

$$\text{or } \angle CAO = 180^\circ - \gamma$$

We know that in triangle AOC

$$\frac{OA}{\sin(\angle ACO)} = \frac{AC}{\sin(\angle AOC)} = \frac{OC}{\sin(\angle CAO)}$$

$$\frac{OA}{\sin(180^\circ - \alpha)} = \frac{AC}{\sin(180^\circ - \beta)} = \frac{OC}{\sin(180^\circ - \gamma)}$$

$$\frac{P}{\sin \alpha} = \frac{Q}{\sin \beta} = \frac{R}{\sin \gamma}$$

**Example 2.1:** An electric light fixture weighting 15 N hangs from a point C, by two strings AC and BC. The string AC is inclined at 60° to the horizontal and BC at 45° to the horizontal as shown in Fig. Using Lami's theorem, or otherwise, determine the forces in the strings AC and BC.

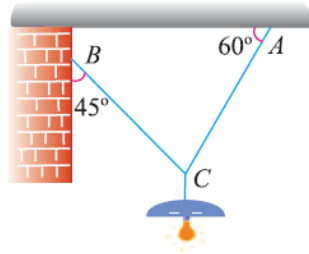

Fig 2.6

**Solution.**

Given:

Weight at C = 15 N

Let  $T_{AC}$  = Force in the string AC, and

$T_{BC}$  = Force in the string BC.

The system of forces is shown in Fig. From the geometry of the figure, we find that angle between  $T_{AC}$  and 15 N is 150° and angle between  $T_{BC}$  and 15 N is 135°.

$\angle ACB = 180^\circ - (45^\circ + 60^\circ) = 75^\circ$ . Applying Lami's equation at C,

$$\frac{15}{\sin 75^\circ} = \frac{T_{AC}}{\sin 135^\circ} = \frac{T_{BC}}{\sin 150^\circ}$$

$$\frac{15}{\sin 75^\circ} = \frac{T_{AC}}{\sin 45^\circ} = \frac{T_{BC}}{\sin 30^\circ}$$

$$T_{AC} = \frac{15 \sin 45^\circ}{\sin 75^\circ} = \frac{15 \times 0.707}{0.9659} = 10.98 \text{ N}$$

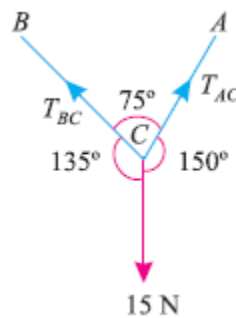

Fig 2.7

$$T_{BC} = \frac{15 \sin 30^\circ}{\sin 75^\circ} = \frac{15 \times 0.5}{0.9659} = 7.76 \text{ N}$$

**Example 2.2:** A string ABCD, attached to fixed points A and D has two equal weights of 1000 N attached to it at B and C. The weights rest with the portions AB and CD inclined at angles as shown in Fig2.8 . Find the tensions in the portions AB, BC and CD of the string, if the inclination of the portion BC with the vertical is 120°.



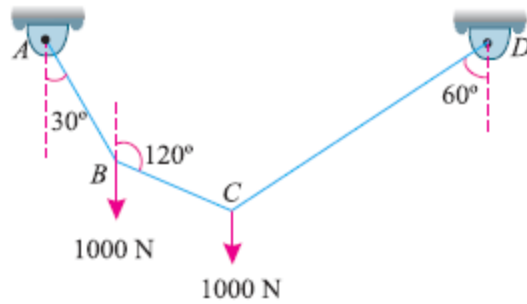

Fig 2.8

**Solution:** Given : Load at  $B$  = Load at  $C$  = 1000 N For the sake of convenience, let us split up the string  $ABCD$  into two parts. The system of forces at joints  $B$  and is shown in Fig.2.9 (a) and (b).

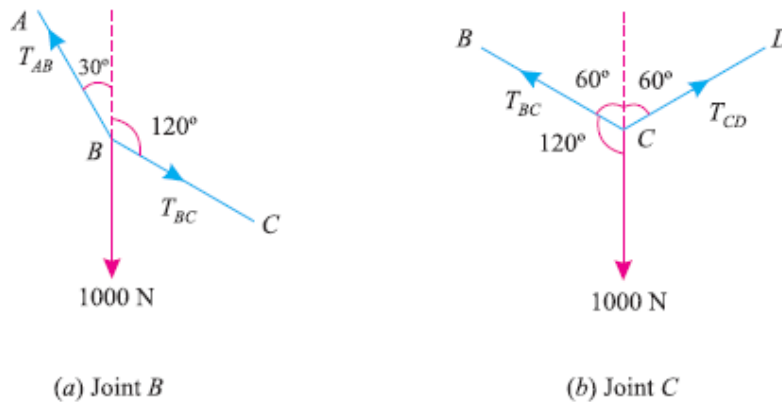

Fig 2.9

Let

$T_{AB}$  = Tension in the portion  $AB$  of the string,  
 $T_{BC}$  = Tension in the portion  $BC$  of the string, and  
 $T_{CD}$  = Tension in the portion  $CD$  of the string.

Applying Lami's equation at joint  $B$ ,

$$\frac{T_{AB}}{\sin 60^\circ} = \frac{T_{BC}}{\sin 150^\circ} = \frac{1000}{\sin 150^\circ}$$

$$\frac{T_{AB}}{\sin 60^\circ} = \frac{T_{BC}}{\sin 30^\circ} = \frac{1000}{\sin 30^\circ}$$

...[ $\because \sin (180^\circ - \theta) = \sin \theta$ ]

$$T_{AB} = \frac{1000 \sin 60^\circ}{\sin 30^\circ} = \frac{1000 \times 0.866}{0.5} = 1732 \text{ N Ans.}$$

$$T_{BC} = \frac{1000 \sin 30^\circ}{\sin 30^\circ} = 1000 \text{ N Ans.}$$

Again applying Lami's equation at joint C,

$$\frac{T_{BC}}{\sin 120^\circ} = \frac{T_{CD}}{\sin 120^\circ} = \frac{1000}{\sin 120^\circ}$$

$$T_{CD} = \frac{1000 \sin 120^\circ}{\sin 120^\circ} = 1000 \text{ N Ans.}$$

**Example 2.3.** A light string ABCDE whose extremity A is fixed, has weights W<sub>1</sub> and W<sub>2</sub> attached to it at B and C. It passes round a small smooth peg at D carrying a weight of 300 N at the free end E as shown in Fig 2.10 below. If in the equilibrium position, BC is horizontal and AB and CD make 150° and 120° with BC, find (i) Tensions in the portion AB, BC and CD of the string and (ii) Magnitudes of W<sub>1</sub> and W<sub>2</sub>.

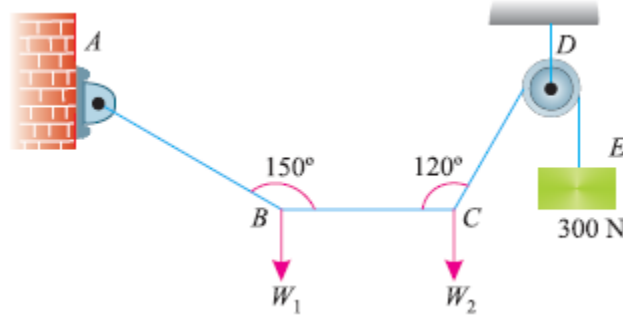

Fig 2.10

**Solution:** Given: Weight at E = 300 N For the sake of convenience, let us split up the string ABCD into two parts. The system of forces at joints B and C is shown in Fig (a) and (b).

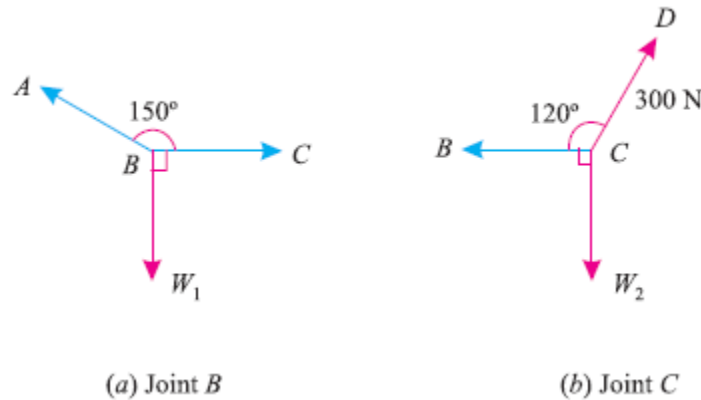

Fig 2.11

(i) Tensions in the portion AB, BC and CD of the string

Let  $T_{AB}$  = Tension in the portion AB, and

$T_{BC}$  = Tension in the portion BC,

We know that tension in the portion CD of the string.

$T_{CD} = T_{DE} = 300 \text{ N Ans.}$

Applying Lami's equation at C,

$$\frac{T_{BC}}{\sin 150^\circ} = \frac{W_2}{\sin 120^\circ} = \frac{300}{\sin 90^\circ}$$

$$\frac{T_{BC}}{\sin 30^\circ} = \frac{W_2}{\sin 60^\circ} = \frac{300}{1}$$

...[∵ sin (180° - θ) = sin θ]

$$T_{BC} = 300 \sin 30^\circ = 300 \times 0.5 = 150 \text{ N Ans.}$$

$$W_2 = 300 \sin 60^\circ = 300 \times 0.866 = 259.8 \text{ N}$$

Again applying Lami's equation at B,

$$\frac{T_{AB}}{\sin 90^\circ} = \frac{W_1}{\sin 150^\circ} = \frac{T_{BC}}{\sin 120^\circ}$$

$$\frac{T_{AB}}{1} = \frac{W_1}{\sin 30^\circ} = \frac{150}{\sin 60^\circ}$$

...[∵ sin (180° - θ) = sin θ]

$$T_{AB} = \frac{150}{\sin 60^\circ} = \frac{150}{0.866} = 173.2 \text{ N Ans.}$$

$$W_1 = \frac{150 \sin 30^\circ}{\sin 60^\circ} = \frac{150 \times 0.5}{0.866} = 86.6 \text{ N}$$

(ii) Magnitudes of  $W_1$  and  $W_2$

From the above calculations, we find that the magnitudes of  $W_1$  and  $W_2$  are 86.6 N and 259.8 N respectively.

**Example 2.4** Two cylinders P and Q rest in a channel as shown in Fig 2.12. The cylinder P has diameter of 100 mm and weighs 200 N, whereas the cylinder Q has diameter of 180 mm and weighs 500 N. If the bottom width of the box is 180 mm, with one side vertical and the other inclined at 60°, determine the pressures at all the four points of contact.

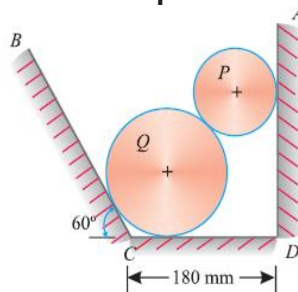

Fig 2.12

Soln.: Given : Diameter of cylinder P = 100 mm ; Weight of cylinder P = 200 N ;  
Diameter of cylinder Q = 180 mm ; Weight of cylinder Q = 500 N and width of channel = 180 mm.

First of all, consider the equilibrium of the cylinder P

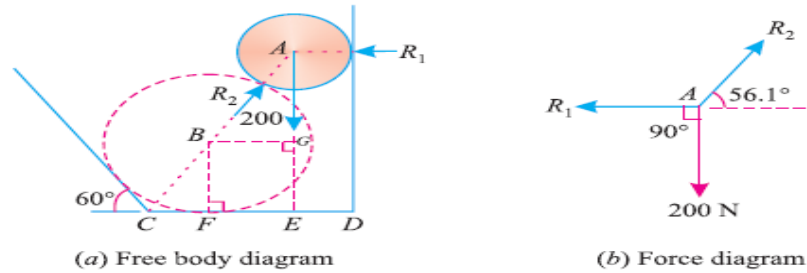

Fig 2.13

From the geometry of the figure, we find that  
 $ED = \text{Radius of cylinder P} = 100/2 = 50 \text{ mm}$   
 $BF = \text{Radius of cylinder Q} = 180/2 = 90 \text{ mm}$   
 $\angle BCF = 60^\circ$

$$\therefore CF = BF \cot 60^\circ = 90 \times 0.577 = 52 \text{ mm}$$

$$FE = BG = 180 - (52 + 50) = 78 \text{ mm}$$

$$AB = 50 + 90 = 140 \text{ mm}$$

$$\cos \angle ABG = BG/AB = 78/140 = 0.5571$$

$$\angle ABG = 56.1^\circ$$

Applying Lami's theorem at A,

$$\frac{R_1}{\sin(90^\circ + 56.1^\circ)} = \frac{R_2}{\sin 90^\circ} = \frac{200}{\sin(180^\circ - 56.1^\circ)}$$

$$\frac{R_1}{\cos 56.1^\circ} = \frac{R_2}{1} = \frac{\sin 56.1^\circ}{\sin 56.1^\circ}$$

$$\therefore R_1 = \frac{200 \cos 56.1^\circ}{\sin 56.1^\circ} = \frac{200 \times 0.5571}{0.830} = 134.2 \text{ N}$$

$$\text{And } R_2 = \frac{200}{\sin 56.1^\circ} = \frac{200}{0.8300} = 240.8 \text{ N}$$

**Example 2.5** Three cylinders weighting 100 N each and of 80 mm diameter are placed in a channel of 180 mm width as shown in Fig. Determine the pressure exerted by (i) the cylinder A on B at the point of contact (ii) the cylinder B on the base and (iii) the cylinder B on the wall.

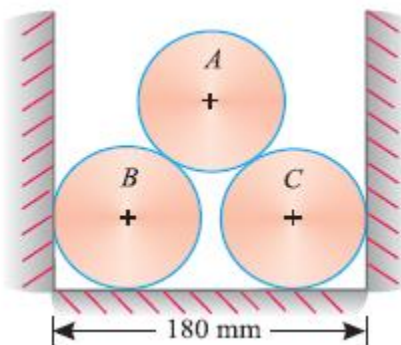

Fig 2.14

**Solution.** Given: Weight of each cylinder = 100 N; Dia. of each cylinder = 80 mm and width of channel = 180 mm

(i) Pressure exerted by the cylinder A on the cylinder B

Let  $R_1$  = Pressure exerted by the cylinder A on B. It is also equal to pressure exerted by the cylinder A on B.

First of all, consider the equilibrium of the cylinder A. It is in equilibrium under the action of the following forces, which must pass through the centre of the cylinder as shown in Fig 2.15 (a).

1. Weight of the cylinder 100 N acting downwards.
2. Reaction  $R_1$  of the cylinder B on the cylinder A.
3. Reaction  $R_2$  of the cylinder C on the cylinder A.

Now join the centres O, P and Q of the three cylinders. Bisect PQ at S and join OS as shown in Fig 2.15 (b).

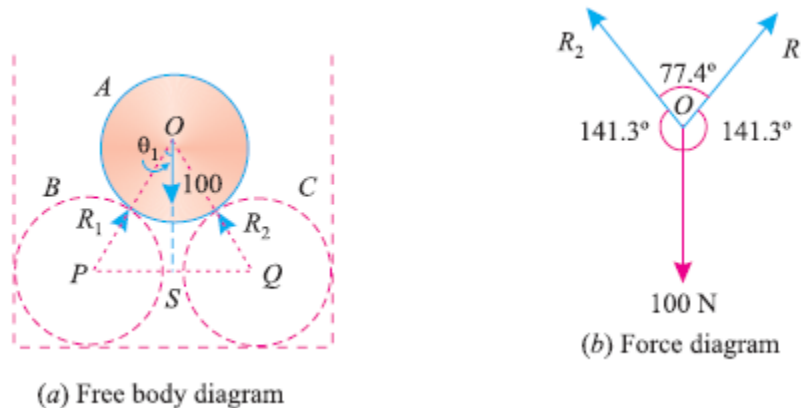

Fig 2.15

From the geometry of the triangle OPS, we find that

$$OP = 40 + 40 = 80 \text{ mm}$$

and  $PS = 90 - 40 = 50 \text{ mm}$

$$\sin \angle POS = \frac{PS}{OP} = \frac{50}{80} = 0.625$$

$$\angle POS = 38.7^\circ$$

Since the triangle OSQ is similar to the triangle OPS, therefore  $\angle SOQ$  is also equal to  $38.7^\circ$ . Thus the angle between  $R_1$  and  $R_2$  is  $2 \times 38.7^\circ = 77.4^\circ$ . And angle between  $R_1$  and OS (also between  $R_2$  and OS). =  $180^\circ - 38.7^\circ = 141.3^\circ$

The system of forces at O is shown in Fig (b).

Applying Lami's equation at O,

$$\frac{R_1}{\sin 141.3^\circ} = \frac{R_2}{\sin 141.3^\circ} = \frac{100}{\sin 77.4^\circ}$$

$$\frac{R_1}{\sin 38.7^\circ} = \frac{R_2}{\sin 38.7^\circ} = \frac{100}{\sin 77.4^\circ} \quad \dots[\because \sin(180^\circ - \theta) = \sin \theta]$$

$$R_1 = \frac{100 \times \sin 38.7^\circ}{\sin 77.4^\circ} = \frac{100 \times 0.6252}{0.9759} = 64.0 \text{ N} \quad \text{Ans.}$$

$$R_2 = R_1 = 64.0 \text{ N} \quad \text{Ans.}$$

(ii) Pressure exerted by the cylinder B on the base

Let  $R_3$  = Pressure exerted by the cylinder B on the wall, and

$R_4$  = Pressure exerted by the cylinder B on the base.

Now consider the equilibrium of the cylinder B. It is in equilibrium under the action of the following forces, which must pass through the centre of the cylinder as shown in Fig 2.16 (a).

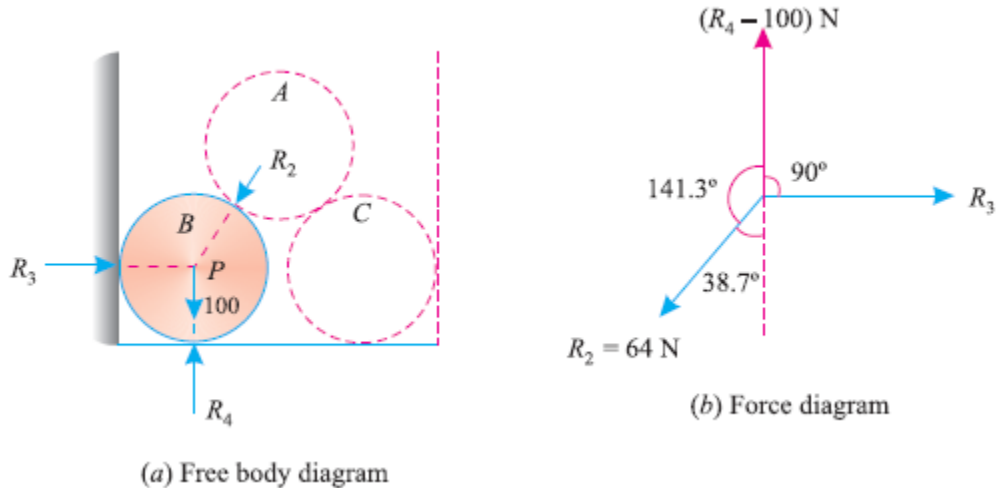

Fig 2.16

1. Weight of the cylinder 100 N acting downwards.
2. Reaction  $R_2$  equal to 64.0 N of the cylinder A on the cylinder B.
3. Reaction  $R_3$  of the cylinder B on the vertical side of the channel.
4. Reaction  $R_4$  of the cylinder B on the base of the channel.

A little consideration will show that weight of the cylinder B is acting downwards and the reaction  $R_4$  is acting upwards. Moreover, their lines of action also coincide with each other. Therefore net downward force will be equal to  $(R_4 - 100)$  N. The system of forces is shown in Fig 2.16 (b). Applying Lami's equation at P,

$$\frac{64}{\sin 90^\circ} = \frac{R_3}{\sin (180^\circ - 38.7^\circ)} = \frac{(R_4 - 100)}{\sin (90^\circ + 38.7^\circ)}$$

$$\frac{64}{1} = \frac{R_3}{\sin 38.7^\circ} = \frac{R_4 - 100}{\cos 38.7^\circ}$$

$$R_4 - 100 = 64 \cos 38.7^\circ = 64 \times 0.7804 = 50 \text{ N}$$

$R_4 = 50 + 100 = 150 \text{ N}$  **Ans.**

(iii) Pressure exerted by the cylinder B on the wall. From the above Lami's equation, we also find that

$$R_3 = 64 \sin 38.7^\circ = 64 \times 0.6252 = 40 \text{ N}$$
 **Ans.**

**Note.** Since the cylinders B and C are symmetrically placed, therefore pressures exerted by the cylinder C on the wall as well as channel will be the same as those exerted by the cylinder B.

### GRAPHICAL METHOD FOR THE EQUILIBRIUM OF COPLANAR FORCES

The equilibrium of coplanar forces may also be studied, graphically, by drawing the vector diagram. This may also be done by studying the

1. Converse of the Law of Triangle of Forces.
2. Converse of the Law of Polygon of Forces.

### CONVERSE OF THE LAW OF TRIANGLE OF FORCES

If three forces acting at a point be represented in magnitude and direction by the three sides a triangle, taken in order, the forces shall be in equilibrium.

### CONVERSE OF THE LAW OF POLYGON OF FORCES

If any number of forces acting at a point be represented in magnitude and direction by the sides of a closed polygon, taken in order, the forces shall be in equilibrium.

**Example 2.6** Five strings are tied at a point and are pulled in all directions, equally spaced from one another. If the magnitude of the pulls on three consecutive strings is 50 N, 70 N and 60 N respectively, find graphically the magnitude of the pulls on two other strings.

**Solution.** Given : Pulls = 50 N ; 70 N and 60 N and angle between the forces =  $360/5=72^\circ$   
Let  $P_1$  and  $P_2$  = Pulls in the two strings.

First of all, let us draw the space diagram for the given system of forces and name them according to Bow's notations as shown in Fig(a)

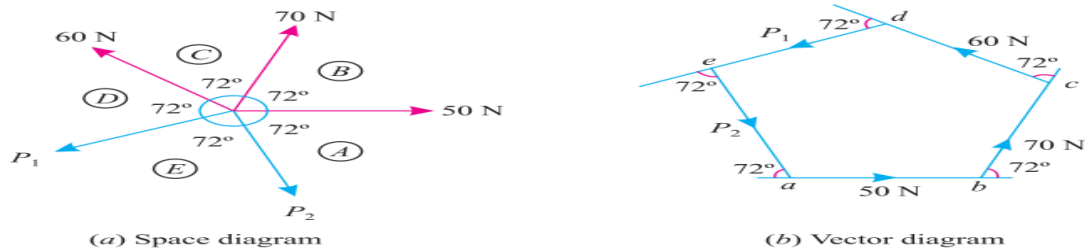

Fig 2.17

Now draw the vector diagram for the given forces as shown in Fig 2.17 (b) and as discussed below :

1. Select some suitable point  $a$  and draw a horizontal line  $ab$  equal to 50 N to some suitable scale representing the force  $AB$ .
2. Through  $b$  draw a line  $bc$  equal to 70 N to the scale and parallel to  $BC$ .
3. Similarly through  $c$ , draw  $cd$  equal to 60 N to the scale and parallel to  $CD$ .
4. Through  $d$  draw a line parallel to the force  $P_1$  of the space diagram.
5. Similarly through  $a$  draw a line parallel to the force  $P_2$  meeting the first line at  $e$ , thus closing the polygon  $abcde$ , which means that the point is in equilibrium.
6. By measurement, we find that the forces  $P_1 = 57.5$  N and  $P_2 = 72.5$  N respectively. **Ans**

## EXERCISE

1. Enunciate any two principles of equilibrium.
2. State and prove Lami's Theorem.
3. Show that if three coplaner forces, acting at a point be in equilibrium, then, each force is proportional to the sine of the angle between the other two.
4. What are different methods of studying the equilibrium of coplaner forces ? Describe any one of them.
5. How would you find out the equilibrium of non-coplaner forces ?
6. Explain the conditions of equilibrium.
7. Discuss the various types of equilibrium.
8. Two equal heavy spheres of 50 mm radius are in equilibrium within a smooth cup of 150 mm radius. Show that the reaction between the cups of one sphere is double than that between the two spheres.
9. A smooth circular cylinder of radius 1.5 meter is lying in a triangular groove, one side of which makes  $15^\circ$  angle and the other  $40^\circ$  angle with the horizontal. Find the reactions at the surfaces of contact, if there is no friction and the cylinder weights 100 N. **Ans. 78.5, 31.6**
10. An electric light fixture weighing 15 N hangs from a point C, by two strings AC and BC. The string AC is inclined at  $60^\circ$  to the horizontal and BC at  $45^\circ$  to the horizontal as shown in Fig. **Ans. 1N, 7.8N**

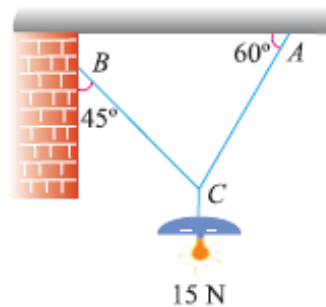



## CHAPTER3: FRICTION

On completion of the subject, the student will be able to:

- Define and classify friction
- Know about advantages and disadvantages of friction
- Understand and Compute about equilibrium of bodies on level plane
- Understand the application of friction and apply it to solve problems

**3.1 FRICTIONAL FORCE:** It is the resisting force which oppose the movement the body, it always acts opposite the movement of the body.

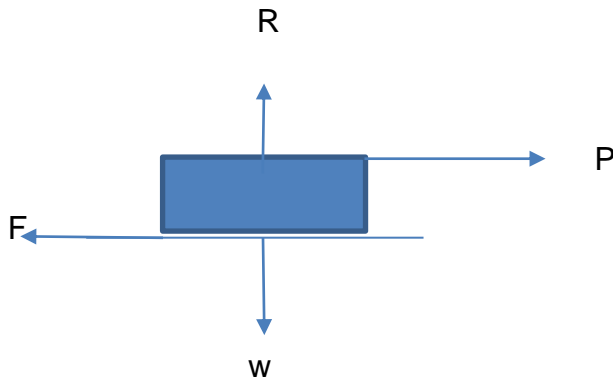

Fig 3.1

Where  $P$  = applied force

$F$  = frictional force

$W$  = weight of the body

$R$  = normal reaction.

Classification of the friction:

- The frictional forces are classified into two types: (i) Static friction  
(ii) Dynamic Friction

### STATIC FRICTION:

It is the friction experienced by a body when it is at rest, Or in other words, it is the friction when the body is tends to move.

### DYNAMIC FRICTION:

It is the friction experience by a body when it is in motion. It is also called kinetic friction. The Dynamic friction is further divided into two types

- (i) Sliding friction: It is the friction experienced by a body when it slides over another body.
- (ii) rolling friction: It is the friction experience by a body when it rolls over another body.

### LIMITING FRICTION:

The maximum friction that can be generated between two static surfaces in contact with each other. Once a force applied to the two surfaces exceeds the limiting friction, motion will occur. For two dry surfaces, the limiting friction is a product of the normal reaction force and the coefficient of limiting friction.

### NORMAL REACTION:

Whenever a body, lying on a horizontal or an inclined surface, is in equilibrium, its weight acts vertically downwards through its centre of gravity. The surface, in turn, exerts an upward reaction on the body. This reaction, which is taken to act perpendicular to the plane, is called normal reaction and is, generally, denoted by  $R$  or  $(R_n)$

If weight is the only vertical force acting on an object lying or moving on a horizontal surface, the *normal reaction force* is equal in magnitude, but opposite in direction to the weight. It is always acting perpendicular to the plane.

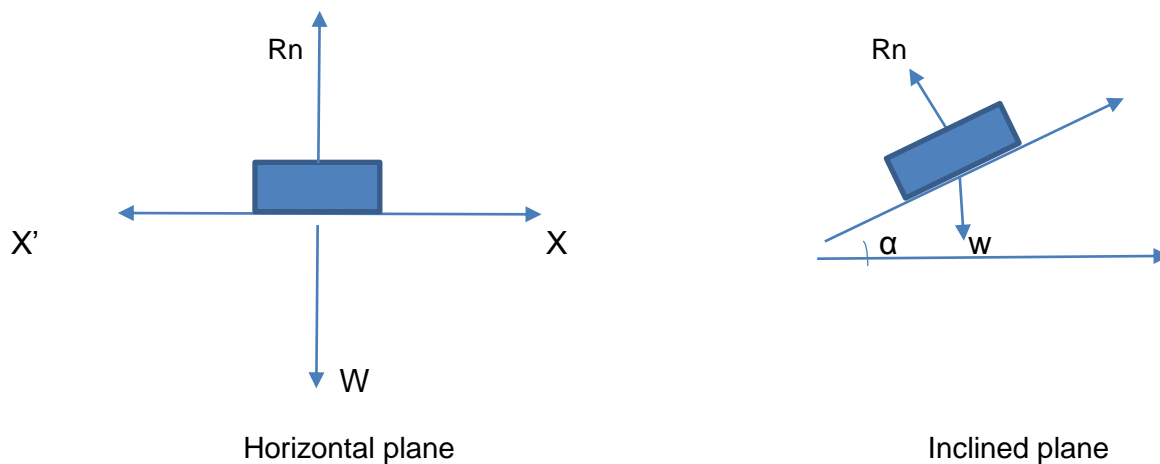

Fig 3.2

### ANGLE OF FRICTION:

It is the angle between the normal reaction and resultant force of normal reaction and frictional forces or limiting friction. This angle is generally specified by  $\theta$ .

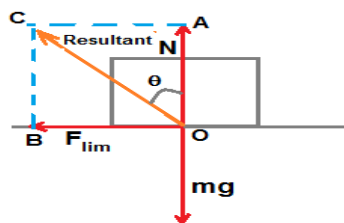

Fig 3.3

## ANGLE OF REPOSE:

It is an angle of the inclined plane at which the body tends to slide downwards. This angle is generally specified by  $\alpha$

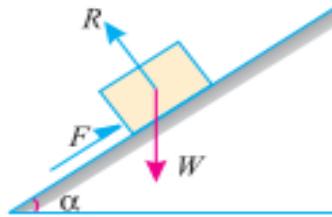

Fig 3.4

## COEFFICIENT OF FRICTION:

It is the ratio of limiting friction or frictional force and normal reaction. It is generally denoted by  $\mu$  (mu).

In mathematically:

$$\mu = \frac{F}{R} = \tan \phi \quad \text{or} \quad F = \mu R$$

Where  $\phi$  = Angle of friction

$F$  = Frictional force

$R$  = Normal reaction

$\mu$  = Coefficient of friction.

## LAWS OF FRICTION:

There are two types of laws of friction.

- (i) Laws of Static friction, and
- (ii) Laws of dynamic or kinetic friction.

## LAWS OF STATIC FRICTION:

1. The force of friction always acts opposite of the applied force or body tends to move.
2. The magnitude the frictional force is exactly equal to the applied force.
3. The magnitude of limiting friction bears constant ratio to the normal reaction between the two surfaces. Mathematically,

$$\frac{F}{R} = \text{constant} \quad \text{where } F = \text{Limiting friction}$$

$R$  = Normal reaction.

4. The force of friction is independent of the area contact between the two surfaces.
5. The force of friction depends upon the roughness of the surfaces.

## LAWS OF KINETIC OR DYNAMIC FRICTION:

1. The force of friction always acts in a direction, opposite to that in which the body is moving
2. The magnitude of kinetic friction bears constant ratio to the normal reaction between the two surfaces. But this ratio is slightly less than that in case of limiting friction.
3. For moderate speeds, the force of friction remains constant. But it decreases slightly with the increase of speed.

## ADVANTAGES OF FRICTION:

- Friction is responsible for many types of motion
- It helps us walk on the ground
- Brakes in a car make use of friction to stop the car
- Asteroids are burnt in the atmosphere before reaching Earth due to friction.
- It helps in the generation of heat when we rub our hands.

## DISADVANTAGES OF FRICTION:

- Friction produces unnecessary heat leading to the wastage of energy.
- The force of friction acts in the opposite direction of motion, so friction slows down the motion of moving objects.
- Forest fires are caused due to the friction between tree branches.
- A lot of money goes into preventing friction and the usual wear and tear caused by it by using techniques like greasing and oiling.

## 3.2 EQUILIBRIUM OF BODIES ON LEVEL PLANE

### EQUILIBRIUM OF A BODY ON A ROUGH HORIZONTAL PLANE:

We know that a body, lying on a rough horizontal plane will remain in equilibrium. But whenever a force is applied on it, the body will tend to move in the direction of the force. In cases equilibrium of the body is studied first by resolving the forces horizontally and then vertically.

Now the value of the force of friction is obtained from the relation:

$$F = \mu R$$

Where  $\mu$  = Coefficient of friction, and

$R$  = Normal reaction.

**Example:3.1.** A body of weight 500N is lying on a rough horizontal plane having a coefficient of friction as 0.3. Find the magnitude of the force, which can move the body, while acting at an angle of  $35^\circ$  with horizontal.

Solution: Data given: Weight of the body ( $w$ ) = 500N

Coefficient of friction ( $\mu$ ) = 0.3

Inclined angle ( $\alpha$ ) =  $35^\circ$

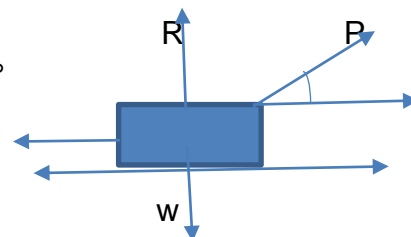

Fig 3.5

Let

$P$  = Magnitude of the force, which can move the body, and

$F$  = Frictional force.

Resolving the forces horizontally,

$$F = p \times \cos 35^\circ \quad [F = \mu R]$$

$$\mu R = p \times \cos 35^\circ \text{-----(i)}$$

Resolving the forces vertically

$$R = W - P \times \sin \alpha \quad \text{--}$$

$$R = 500 - P \times \sin 35^\circ \text{-----(ii)}$$

Now substituting the value of  $R$  in equation (i)

$$\mu (500 - p \times \sin 35^\circ) = P \times \cos 35^\circ$$

$$0.3(500 - P \times \sin 35^\circ) = p \times \cos 35^\circ$$

$$0.3 \times 500 = 0.3 \times p \sin 35^\circ + p \times \cos 35^\circ$$

$$150 = P (0.3 \times \sin 35^\circ + \cos 35^\circ)$$

$$P = \frac{150}{0.3 \sin 35^\circ + \cos 35^\circ}$$

$$P = 151.3 \text{ N} \quad \text{Ans.}$$

### EQUILIBRIUM OF A BODY ON A ROUGH INCLINED PLANE:

Here the forces are applied in three ways that are

1. Force acting along the inclined plane.
2. Force acting horizontally.
3. Force acting at some angle with the inclined plane.

#### 1. EQUILIBRIUM OF A BODY ON A ROUGH INCLINED PLANE SUBJECTED TO A FORCE ACTING ALONG THE INCLINED PLANE:

Consider a body lying on a rough inclined plane subjected to a force acting along the inclined plane

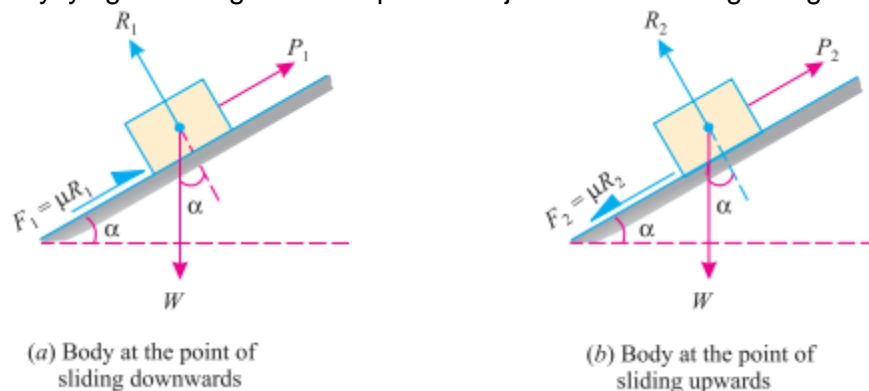

Fig 3.6

Let  $w$  = Weight of the body

$\alpha$  = Angle, which the inclined plane makes with the horizontal

$R$  = Normal reaction

$\mu$  = Coefficient of friction between the body and the inclined plane,

$\phi =$  Angle of friction, such that  $\mu = \tan \phi$ .

A little consideration will show that if the force is not there, the body will slide down the plane. Now we shall discuss the above two cases:

**Case 1.** Minimum force ( $P_1$ ) which will keep the body in equilibrium, when it is at the point of sliding downwards.

Resolving all the forces along the inclined plane:

$$P_1 + F = W \sin \alpha$$

$$P_1 = W \sin \alpha - F \quad [ F = \mu R ]$$

$$P_1 = W \sin \alpha - \mu R \quad \text{-----(i)}$$

Now resolving all the forces perpendicular to the plane:

$$R = W \cos \alpha \quad \text{-----(ii)}$$

Substituting the value of R in equation (i)

$$P_1 = W \sin \alpha - \mu W \cos \alpha$$

$$P_1 = W (\sin \alpha - \mu \cos \alpha)$$

And now substituting the value of  $\mu = \tan \phi$  in the above equation.

$$P_1 = W (\sin \alpha - \tan \phi \cos \alpha)$$

Multiplying both sides of this equation by  $\cos \phi$

$$P_1 \cos \phi = W (\sin \alpha \cos \phi - \sin \phi \cos \alpha)$$

$$P_1 = W \times \frac{\sin(\alpha - \phi)}{\cos \phi}$$

**Case 2:** Maximum force ( $P_2$ ) which will keep the body in equilibrium, when it is at the point of sliding upwards.

Resolving all the forces along the inclined plane:

$$P_2 = W \sin \alpha + \mu R \quad \text{-----(i)}$$

Now resolving all the forces perpendicular to the inclined plane:

$$R = W \cos \alpha \quad \text{-----(ii)}$$

Substituting the value of r in equation (i),

$$P_2 = W \sin \alpha + \mu W \cos \alpha$$

$$= W (\sin \alpha + \mu \cos \alpha)$$

And now Substituting the value of  $\mu = \tan \phi$  in the above equation,

$$P_2 = W (\sin \alpha + \tan \phi \cos \alpha)$$

Multiplying both sides of this equation by  $\cos \phi$ ,

$$P_2 \cos \phi = W (\sin \alpha \cos \phi + \sin \phi \cos \alpha)$$

$$P_2 \cos \phi = W \sin (\alpha + \phi)$$

$$P_2 = \frac{W \sin (\alpha + \phi)}{\cos \phi} \text{ (maximum force which keep the body in equilibrium)}$$

## 2. EQUILIBRIUM OF A BODY ON A ROUGH INCLINED PLANE SUBJECTED TO A FORCE ACTING HORIZONTALLY.

Considering a body lying on a rough inclined plane subjected to a force acting horizontally, which keeps it in equilibrium as shown in fig 3.7 (a) and (b)

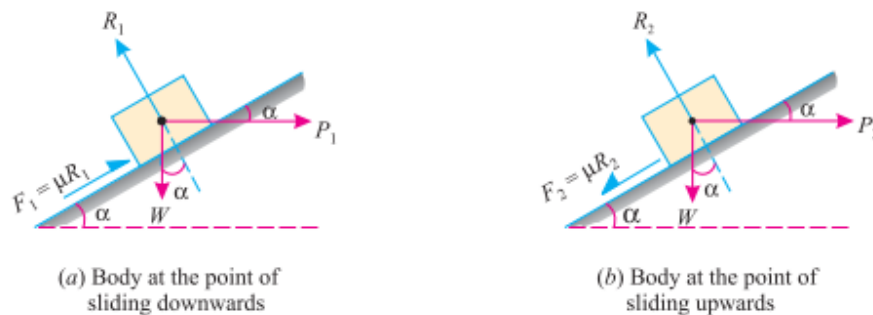

Fig 3.7

Let  $W$  - Weight of the body  
 $\alpha$  = Angle of inclination with horizontal  
 $R$  = Normal reaction  
 $\mu$  = Coefficient of friction between the body and the inclined plane  
 $\phi$  = Angle of friction.

**Case 1:** Minimum force ( $P_1$ ) which will keep the body in equilibrium, when it is at the point of sliding downwards.

Resolving the all the forces inclined plane:

$$P_1 \cos \alpha = W \sin \alpha - \mu R$$

And now resolving all the forces perpendicular to the plane,

$$R = W \cos \alpha + P_1 \sin \alpha$$

Substituting this value of  $R$  in equation (i)

$$P_1 \cos \alpha = W \sin \alpha - \mu (W \cos \alpha + P_1 \sin \alpha)$$

$$= W \sin \alpha - \mu W \cos \alpha - \mu P_1 \sin \alpha$$

$$P_1 \cos \alpha + \mu P_1 \sin \alpha = W \sin \alpha - \mu W \cos \alpha$$

$$P_1 (\cos \alpha + \mu \sin \alpha) = W (\sin \alpha - \mu \cos \alpha)$$

$$P_1 = W \times \frac{\sin \alpha - \mu \cos \alpha}{\cos \alpha + \mu \sin \alpha}$$

$$P_1 = W \times \frac{\sin \alpha - \tan \phi \cos \alpha}{\cos \alpha + \tan \phi \sin \alpha}$$

Multiplying the numerator and denominator by  $\cos \phi$ ,

$$P_1 = W \times \frac{\sin \alpha \cos \phi - \sin \phi \cos \alpha}{\cos \alpha \cos \phi + \sin \phi \sin \alpha}$$

$$P_1 = W \times \frac{\sin(\alpha - \phi)}{\cos(\alpha - \phi)}$$

$$P_1 = W \tan(\alpha - \phi) \text{ ----- Minimum force}$$

**Case 2:** Maximum force ( $P_2$ ) which will keep the body in equilibrium, when it is at the point of sliding Upwards

Resolving all the forces along the inclined plane,

$$P_2 \cos \alpha = F + W \sin \alpha$$

$$P_2 \cos \alpha = \mu R + W \sin \alpha \text{ -----(i)}$$

Resolving all the forces perpendicular to the plane,

$$R = W \cos \alpha + P_2 \sin \alpha \text{ ----- (ii)}$$

Now substituting the value of R in equation (i)

$$P_2 \cos \alpha = \mu W \cos \alpha + P_2 \sin \alpha + W \sin \alpha$$

$$P_2 \cos \alpha - \mu P_2 \sin \alpha = \mu W \cos \alpha + W \sin \alpha$$

$$P_2 (\cos \alpha - \mu \sin \alpha) = W (\sin \alpha + \mu \cos \alpha)$$

$$P_2 = W \times \frac{\sin \alpha + \mu \cos \alpha}{\cos \alpha - \mu \sin \alpha}$$

$$P_2 = W \times \frac{\sin \alpha + \tan \phi \cos \alpha}{\cos \alpha - \tan \phi \sin \alpha}$$

Multiplying the numerator and denominator by  $\cos \phi$

$$P_2 = W \times \frac{(\sin \alpha \cos \phi + \sin \phi \cos \alpha)}{(\cos \alpha \cos \phi - \sin \phi \sin \alpha)}$$

$$P_2 = W \times \frac{\sin(\alpha + \phi)}{\cos(\alpha + \phi)}$$

$$P_2 = W \times \tan(\alpha + \phi) \text{ ----- Maximum force.}$$

### 3. EQUILIBRIUM OF A BODY ON A ROUGH INCLINED PLANE SUBJECTED TO A FORCE ACTING AT SOME ANGLE WITH THE INCLINED PLANE:

Considering a body lying on a rough inclined plane subjected to a force acting some angle with the inclined plane, which keeps it in equilibrium as shown in fig 3.8(a) and (b)



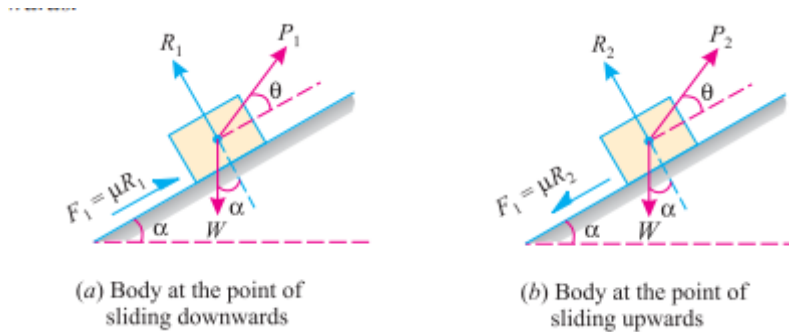

Fig 3.8

**Case 1.** Minimum force ( $P_1$ ) which keep the body in equilibrium when it is at the point of sliding downwards.

Resolving all the forces along the inclined plane,

$$P_1 \cos \theta = W \sin \alpha - F$$

$$P_1 \cos \theta = W \sin \alpha - \mu R \text{-----(i)}$$

Resolving all the forces along perpendicular to the inclined plane,

$$R = W \cos \alpha - P_1 \sin \theta \text{-----(ii)}$$

Substituting the value of R in equation (i)

$$P_1 \cos \theta = W \sin \alpha - \mu(W \cos \alpha - P_1 \sin \theta)$$

$$P_1 \cos \theta - \mu P_1 \sin \theta = W \sin \alpha - \mu W \cos \alpha$$

$$P_1(\cos \theta - \mu \sin \theta) = W(\sin \alpha - \mu \cos \alpha)$$

$$P_1 = W \times \frac{(\sin \alpha - \mu \cos \alpha)}{(\cos \theta - \mu \sin \theta)}$$

Now substituting the value of  $\mu = \tan \phi$  in the above equation.

$$P_1 = W \times \frac{(\sin \alpha - \tan \phi \cos \alpha)}{(\cos \theta - \tan \phi \sin \theta)}$$

Multiplying the numerator and denominator by  $\cos \phi$

$$P_1 = W \times \frac{(\sin \alpha \cos \phi - \tan \phi \cos \alpha)}{(\cos \theta \cos \phi - \tan \phi \sin \theta)}$$

$$P_1 = W \times \frac{(\sin \alpha \cos \phi - \sin \phi \cos \alpha)}{(\cos \theta \cos \phi - \sin \phi \sin \theta)}$$

$$P_1 = W \times \frac{\sin(\alpha - \phi)}{\cos(\theta + \phi)} \text{-----minimum force}$$

**Case 2:** Maximum force( $P_2$ ) which will keep the body in equilibrium, when it is at the point of sliding Upwards.

Resolving all the forces along inclined plane,

$$P_2 \cos \theta = W \sin \alpha + F$$

$$P_2 \cos \theta = W \sin \alpha + \mu R \text{-----(i)}$$

Resolving all the forces along perpendicular to the inclined plane,

$$R = W \cos \alpha - P_2 \sin \theta \text{-----(ii)}$$

Substituting the value of R in equation (i)

$$P_2 \cos \theta = W \sin \alpha + \mu(W \cos \alpha - P_2 \sin \theta)$$

$$P_2 \cos \theta = W \sin \alpha + \mu W \cos \alpha - \mu P_2 \sin \theta$$

$$P_1 \cos \theta + \mu P_1 \sin \theta = W \sin \alpha + \mu W \cos \alpha$$

$$P_1(\cos \theta + \mu \sin \theta) = W (\sin \alpha + \mu \cos \alpha)$$

$$P_1 = W \times \frac{(\sin \alpha + \mu \cos \alpha)}{(\cos \theta + \mu \sin \theta)}$$

Now substituting the value of  $\mu = \tan \phi$  in the above equation.

$$P_1 = W \times \frac{(\sin \alpha + \tan \phi \cos \alpha)}{(\cos \theta + \tan \phi \sin \theta)}$$

Multiplying the numerator and denominator by  $\cos \phi$

$$P_1 = W \times \frac{(\sin \alpha + \tan \phi \cos \alpha)}{(\cos \theta + \tan \phi \sin \theta)}$$

$$P_1 = W \times \frac{(\sin \alpha \cos \phi + \sin \phi \cos \alpha)}{(\cos \theta \cos \phi + \sin \phi \sin \theta)}$$

$$P_1 = W \times \frac{\sin(\alpha + \phi)}{\cos(\theta - \phi)} \text{-----Maximum force}$$

**Example 3.2.** A body of weight 500 N lying on a rough plane inclined at an angle of  $25^\circ$  with horizontal. It is supported by an effort (P) parallel to the plane as shown in fig.

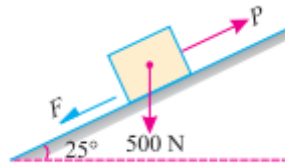

Fig 3.9

**Determine the minimum and maximum, value of P, for which the equilibrium can exist, if the angle of friction is  $20^\circ$ .**

Solution: Data given, Weight of the body (W)=500 N

Angle at which plane is inclined ( $\alpha$ )= $25^\circ$  and

Angle of friction ( $\phi$ )= $20^\circ$

Minimum value ( $P_1$ ) :

We know that for the minimum value  $P_1$ , the body is at the point of sliding upwards. We also know that when the body is at the point of sliding down wards, then the force.

$$P_1 = W \times \frac{\sin(\alpha - \phi)}{\cos \phi}$$

$$P_1 = 500 \times \frac{\sin(25^\circ - 20^\circ)}{\cos 20^\circ} \text{ N}$$

$$P_1 = 500 \times \frac{\sin(5^\circ)}{\cos 20^\circ} \text{ N}$$

$$P_1 = 500 \times \frac{0.0872}{0.9397} \text{ N}$$

$$P_1 = 46.4 \text{ N}$$

Ans.

Maximum value ( $P_2$ ):

We know that for the maximum value  $P_2$  the body is at the point of sliding upwards. We also know that when the body is at the point of sliding down wards, then the force.

$$P_2 = W \times \frac{\sin(\alpha + \phi)}{\cos\phi}$$

$$P_2 = 500 \times \frac{\sin(25^\circ + 20^\circ)}{\cos 20^\circ}$$

$$P_2 = 500 \times \frac{\sin(45^\circ)}{\cos 20^\circ} \text{ N}$$

$$P_2 = 500 \times \frac{0.7071}{0.9397}$$

$$P_2 = 376.2 \text{ N}$$

Ans.

**Example:3.3** An effort of 200N is required just to move a certain body up an inclined plane of angle  $15^\circ$  the force acting parallel to the plane. If the angle of inclination of the plane is made  $20^\circ$  the effort required, again applied parallel to the plane is found to be 230 N. Find the weight of the body and the coefficient of friction.

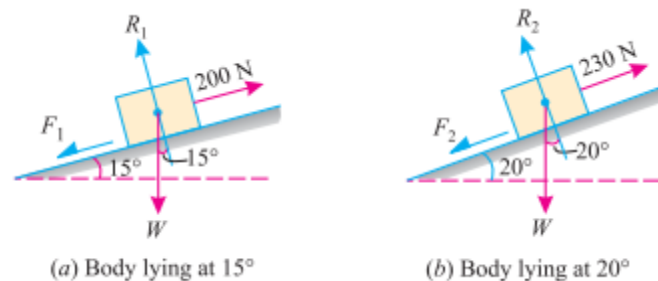

Fig 3.10

**Solution:** Data given, First case: When effort ( $P_1$ ) = 200N

Angle of inclination ( $\alpha$ ) =  $15^\circ$  and

Second case: When effort ( $P_2$ ) = 230N

Angle of inclination =  $20^\circ$

Let  $\mu$  = Coefficient of friction

$W$  = Weight of the body

$R$  = Normal reaction, and

$F$  = Force of friction

First of all, consider the body lying on a plane inclined at angle of  $15^\circ$  with the horizontal and subjected to an effort of 200 N as in fig (a)

Resolving the forces at right to the plane,

$$R_1 = W \cos 15^\circ \text{-----(i)}$$

And now resolving the forces along the plane,

$$200 = F_1 + W \sin 15^\circ \quad [F = \mu R]$$

$$= \mu R_1 + W \sin 15^\circ$$

Substituting the value of  $R_1$  in equation (ii)

$$= \mu W \cos 15^\circ + W \sin 15^\circ$$

$$= W(\mu \cos 15^\circ + \sin 15^\circ) \text{-----(ii)}$$

Now considering the body lying on a plane inclined at an angle of  $20^\circ$  with the horizontal and subjected to an effort of 230 N as shown in fig (b)

Resolving the forces at right to the plane,

$$R_2 = W \cos 20^\circ \text{-----(i)}$$

And now resolving the forces along the plane,

$$230 = F_2 + W \sin 20^\circ$$

$$[F = \mu R]$$

$$= \mu R_2 + W \sin 20^\circ \text{-----(ii)}$$

Substituting the value of  $R_2$  in equation (ii)

$$= \mu W \cos 20^\circ + W \sin 20^\circ$$

$$= W(\mu \cos 20^\circ + \sin 20^\circ)$$

Coefficient of friction

Dividing equation (iv) by (ii)

$$\frac{230}{200} = \frac{W(\mu \cos 20^\circ + \sin 20^\circ)}{W(\mu \cos 15^\circ + \sin 15^\circ)}$$

$$230 \mu \cos 15^\circ + 230 \sin 15^\circ = 200 \mu \cos 20^\circ + 200 \sin 20^\circ$$

$$230 \mu \cos 15^\circ - 200 \mu \cos 20^\circ = 200 \sin 20^\circ - 230 \sin 15^\circ$$

$$\mu (230 \cos 15^\circ - 200 \cos 20^\circ) = 200 \sin 20^\circ - 230 \sin 15^\circ$$

$$\mu = \frac{200 \sin 20^\circ - 230 \sin 15^\circ}{230 \cos 15^\circ - 200 \cos 20^\circ}$$

$$\mu = \frac{(200 \times 0.3420) - (230 \times 0.2588)}{(230 \times 0.9659) - (200 \times 0.9397)} = 0.259 \quad \text{Ans.}$$

Weight of the body.

Substituting the value of  $\mu$  in equation (ii)

$$200 = W (0.259 \cos 15^\circ + \sin 15^\circ)$$

$$= W (0.259 \times 0.9659 + 0.2588)$$

$$= 0.509 W$$

$$W = \frac{200}{0.509} = 392.9 \text{ N} \quad \text{Ans.}$$

**Example:3.4** A load of 1.5 k N, resting on an inclined rough plane, can be moved up the plane by a force of 2 k N applied horizontally or by a force 1.25 k N applied parallel to the plane. Find the inclination of the plane and the coefficient of friction.

**Solution.** Given: Load ( $W$ ) = 1.5 k.N; Horizontal effort ( $P_1$ ) = 2 k.N and effort parallel to the inclined plane ( $P_2$ ) = 1.25 k.N.

Inclination of the plane

Let  $\alpha$  = Inclination of the plane, and  $\phi$  = Angle of friction.

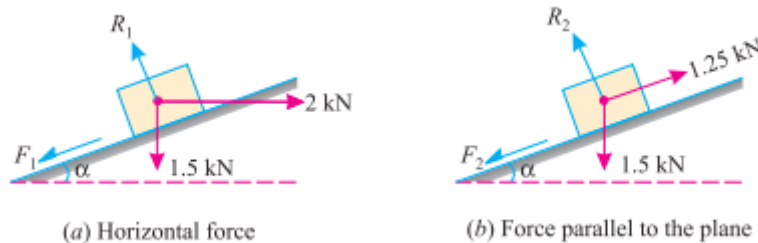

Fig 3.11

First of all, consider the load of 1.5 kN subjected to a horizontal force of 2 kN as shown in Fig. 8.14 (a). We know that when the force is applied horizontally, then the magnitude of the force,

which can move the load up the plane.

$$P = W \tan (\alpha + \phi)$$

Or  $2 = 1.5 \tan (\alpha + \phi)$

$$2 \tan (\alpha + \phi) = \frac{2}{1.5} = 1.333 \text{ or } (\alpha + \phi) = 53.1^\circ$$

Now consider the load of 1.5 kN subjected to a force of 1.25 kN along the plane as shown in Fig. 8.14 (b). We know that when the force is applied parallel to the plane, then the magnitude of the

force, which can move the load up the plane,

$$P = W \times \frac{\sin (\alpha + \phi)}{\cos \phi}$$

$$1.25 = 1.5 \times \frac{\sin 53.1}{\cos \phi}$$

$$= 1.5 \times \frac{0.8}{\cos \phi}$$

$$= \frac{1.2}{\cos \phi}$$

$$\cos \phi = \frac{1.2}{1.25} = 0.96 \text{ or } \phi = 16.3^\circ$$

and  $\alpha = 53.1 - 16.3 = 36.8^\circ$

Ans.

Coefficient of friction

We know that the coefficient of friction.  
 $\mu = \tan \phi = \tan 16.3 = 0.292$

Ans

**Example:3.5** Find the force required to move a load of 300 N up a rough plane, the force being applied parallel to the plane. The inclination of the plane is such that when the same load is kept on a perfectly smooth plane inclined at the same angle, a force of 60 N applied at an inclination of  $30^\circ$  to the plane, keeps the same load in equilibrium. Assume coefficient of friction between the rough plane and the load to be equal to 0.3.

**Solution.**

Given: Load ( $W$ ) = 300 N; Force ( $P_1$ ) = 60 N and angle at which force is inclined ( $\theta$ ) =  $30^\circ$ ,

Let  $\alpha$  = Angle of inclination of the plane.

First of all, consider the load lying on a smooth plane inclined at an angle ( $\alpha$ ) with the horizontal and subjected to a force of 60 N acting at an angle  $30^\circ$  with the plane as shown in Fig.

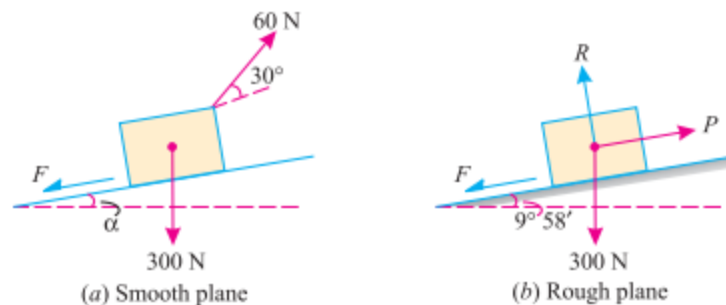

Fig 3.12

We know that in this case, because of the smooth plane  $\mu = 0$  or  $\phi = 0$ . We also know that the force required, when the load is at the point of sliding upwards ( $P$ ),

$$60 = W \times \frac{\sin(\alpha + \phi)}{\cos\theta - \phi}$$

$$= 300 \times \frac{\sin\alpha}{\cos 30^\circ}$$

$$= 300 \times \frac{\sin\alpha}{0.866} = 346.4 \sin\alpha$$

$$\sin\alpha = \frac{60}{346.4} = 0.1732 \text{ N}$$

Or  $\alpha = 10^\circ$

Now consider the load lying on the rough plane inclined at an angle of  $10^\circ$  with the horizontal as shown in Fig. 8.18. (b). We know that in this case,  $\mu = 0.3 = \tan \phi$  or  $\phi = 16.7^\circ$ .

We also know that force required to move the load up the plane,

$$P = W \times \frac{\sin(\alpha + \phi)}{\cos\theta - \phi}$$

$$= 300 \times \frac{\sin(10^\circ + 16.7^\circ)}{\cos 16.7^\circ}$$

$$=300 \times \frac{\sin 26.7^\circ}{\cos 16.7^\circ}$$

$$=300 \times \frac{0.4493}{0.9578} = 140.7 \text{ N}$$

Ans.

### 3.3 APPLICATIONS OF FRICTION

1. Ladder friction
2. Wedge friction
3. Screw friction.

#### LADDER FRICTION

The ladder is a device for climbing or scaling on the roofs or walls. It consists of two long uprights of wood, iron or rope connected by a number of crosspieces called rungs. These rungs serve as steps. Consider a ladder AB resting on the rough ground and leaning against a wall, as shown in figure 3.9.

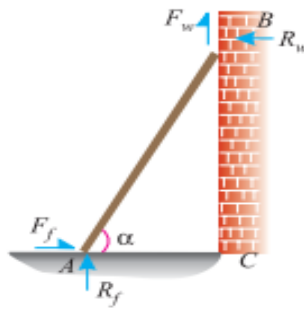

Fig 3.13

As the upper end of the ladder tends to slip downwards, therefore the direction of the force of friction between the ladder and the wall ( $F_w$ ) will be upwards as shown in the figure. Similarly, as the lower end of the ladder tends to slip away from the wall, therefore the direction of the force of friction between the ladder and the floor ( $F_f$ ) will be towards the wall as shown in the figure. Since the system is in equilibrium, therefore the algebraic sum of the horizontal and vertical components of the forces must also be equal to zero.

Note: The normal reaction at the floor ( $R_f$ ) will act perpendicular to the floor. Similarly, normal reaction of the wall ( $R_w$ ) will also act perpendicular to the wall.

**Example 3.6** A uniform ladder of length 3.25 m and weighing 250 N is placed against a smooth vertical wall with its lower end 1.25 m from the wall. The coefficient of friction between the ladder and floor is 0.3. What is the frictional force acting on the ladder at the

point of contact between the ladder and the floor? Show that the ladder will remain in equilibrium in this position.

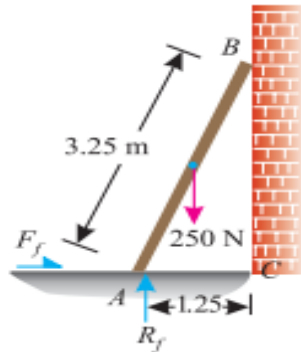

Fig 3.14

**Solution.** Given: Length of the ladder ( $l$ ) = 3.25 m; Weight of the ladder ( $w$ ) = 250 N; Distance between the lower end of ladder and wall = 1.25 m and coefficient of friction between the ladder and floor ( $\mu_f$ ) = 0.3.

Frictional force acting on the ladder.

The forces acting on the ladder.

Let  $F_f$  = Frictional force acting on the ladder at the Point of contact between the ladder and floor, and

$R_f$  = Normal reaction at the floor.

Since the ladder is placed against a smooth vertical wall, therefore there will be no friction at the point of contact between the ladder and wall.

Resolving the forces vertically,

$$R_f = 250 \text{ N}$$

From the geometry of the figure, we find that

$$BC = \sqrt{(3.25)^2 - (1.25)^2} = 3.0 \text{ m}$$

Taking moments about B and equating the same,

$$F_f \times 3 = (R_f \times 1.25) - (250 \times 0.625) = (250 \times 1.25) - 156.3 = 156.2 \text{ N}$$

$$F_f = \frac{156.2}{3} = 52.1 \text{ N} \quad \text{Ans.}$$

Equilibrium of the ladder

We know that the maximum force of friction available at the point of contact between the ladder and the floor

$$\mu R_f = 0.3 \times 250 = 75 \text{ N}$$

Thus, we see that the amount of the force of friction available at the point of contact (75 N) is more than the force of friction required for equilibrium (52.1 N). Therefore, the ladder will remain in an equilibrium position. Ans.

**Example 3.7** A ladder 5 meters long rests on a horizontal ground and leans against a smooth vertical wall at an angle  $70^\circ$  with the horizontal. The weight of the ladder is 900



**N and acts at its middle. The ladder is at the point of sliding, when a man weighing 750N stands on a rung 1.5metre from the bottom of the ladder. Calculate the coefficient of friction between the ladder and the floor.**

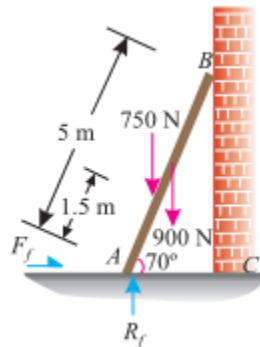

Fig 3.15

**Solution.** Given: Length of the ladder ( $l$ ) = 5 m; Angle which the ladder makes with the horizontal ( $\alpha$ ) =  $70^\circ$ ; Weight of the ladder ( $w_1$ ) = 900 N; Weight of man ( $w_2$ ) = 750 N and distance between the man and bottom of ladder = 1.5 m.

Forces acting on the ladder are shown in Fig.

Let  $\mu_f$  = Coefficient of friction between ladder and floor and

$R_f$  = Normal reaction at the floor.

Resolving the forces vertically,

$$R_f = 900 + 750 = 1650 \text{ N} \dots(i)$$

$\therefore$  Force of friction at A

$$F_f = \mu_f \times R_f = \mu_f \times 1650 \dots(ii)$$

Now taking moments about B, and equating the same,

$$R_f \times 5 \sin 20^\circ = (F_f \times 5 \cos 20^\circ) + (900 \times 2.5 \sin 20^\circ) + (750 \times 3.5 \sin 20^\circ)$$

$$= (F_f \times 5 \cos 20^\circ) + (4875 \sin 20^\circ)$$

$$= (\mu_f \times 1650 \times 5 \cos 20^\circ) + 4875 \sin 20^\circ$$

and now substituting the values of  $R_f$  and  $F_f$  from equations (i) and (ii)

$$1650 \times 5 \sin 20^\circ = (\mu_f \times 1650 \times 5 \cos 20^\circ) + (4875 \sin 20^\circ)$$

Dividing both sides by  $5 \sin 20^\circ$ ,

$$1650 = (\mu_f \times 1650 \cot 20^\circ) + 975$$

$$= (\mu_f \times 1650 \times 2.7475) + 975 = 4533 \mu_f + 975$$

$$\therefore \mu_f = \frac{1650 - 975}{4533} = 0.15 \quad \text{Ans.}$$

### WEDGE FRICTION:

A wedge is, usually, of a triangular or trapezoidal in cross-section. It is, generally, used for slight adjustments in the position of a body i.e. for tightening fits or keys for shafts. Sometimes, a wedge is also used for lifting heavy weights as shown in fig.3.16

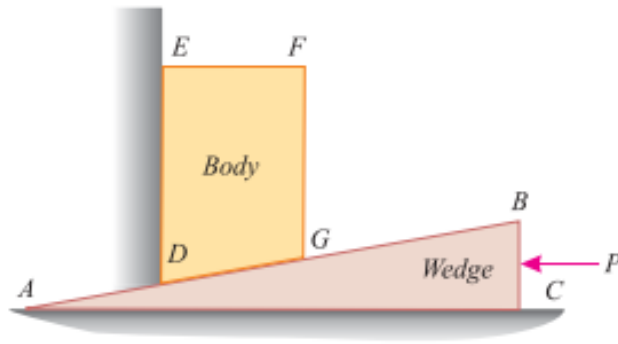

Fig 3.16

It will be interesting to know that the problems on wedges are basically the problems of equilibrium on inclined planes. Thus, these problems may be solved either by the equilibrium method or by applying Lami's theorem. Now consider a wedge ABC, which is used to lift the body DEFG.

Let  $W$  = Weight of the body DEFG,

$P$  = Force required to lift the body, and

$\mu$  = Coefficient of friction on the planes AB, AC and DE such that

$\tan \phi = \mu$ .

It will be interesting to know that the problems on wedges are basically the problems of equilibrium on inclined planes. Thus, these problems may be solved either by the equilibrium method or by applying Lami's theorem. Now consider a wedge ABC, which is used to lift the body DEFG.

Let  $W$  = Weight of the body DEFG,

$P$  = Force required to lift the body, and

$\mu$  = Coefficient of friction on the planes AB, AC and DE such that

$\tan \phi = \mu$ .

A little consideration will show that when the force is sufficient to lift the body, the sliding will take place along three planes AB, AC and DE will also occur as shown in Fig. 3.17 (a) and (b).

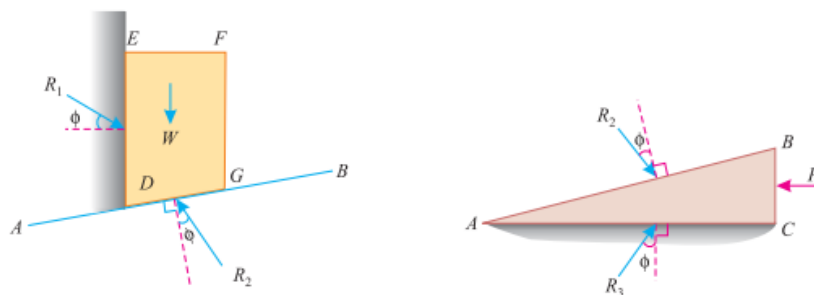

Fig 3.17

The three reactions and the horizontal force ( $P$ ) may now be found out either by graphical method or analytical method as discussed below:

## GRAPHICAL METHOD

1. First of all, draw the space diagram for the body DEFG and the wedge ABC as shown in Fig. 3.18 (a). Now draw the reactions  $R_1$ ,  $R_2$  and  $R_3$  at angle  $\phi$  with normal to the faces DE, AB and AC respectively (such that  $\tan \phi = \mu$ ).

2. Now consider the equilibrium of the body DEFG. We know that the body is in equilibrium under the action of

- (a) Its own weight ( $W$ ) acting downwards
- (b) Reaction  $R_1$  on the face DE, and
- (c) Reaction  $R_2$  on the face AB.

Now, in order to draw the vector diagram for the above mentioned three forces, take some suitable point  $l$  and draw a vertical line  $lm$  parallel to the line of action of the weight ( $W$ ) and cut off  $lm$  equal to the weight of the body to some suitable scale. Through  $l$  draw a line parallel to the reaction  $R_1$ .

Similarly, through  $m$  draw a line parallel to the reaction  $R_2$ , meeting the first line at  $n$  as shown in Fig. 3.18(b).

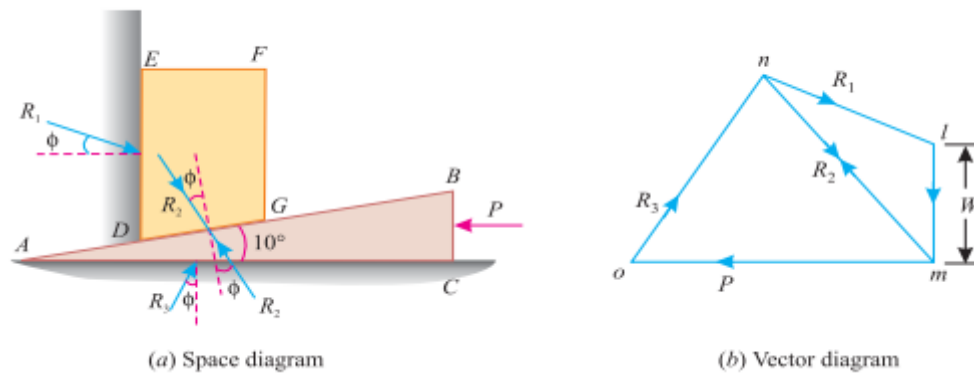

Fig 3.18

3. Now consider the equilibrium of the wedge ABC. We know that it is in equilibrium under the action of

- (a) Force acting on the wedge ( $P$ ),
- (b) Reaction  $R_2$  on the face AB, and
- (c) Reaction  $R_3$  on the face AC.

Now, in order to draw the vector diagram for the above mentioned three forces, through  $m$  draw a horizontal line parallel to the force ( $P$ ) acting on the wedge. Similarly, through  $n$  draw a line parallel to the reaction  $R_3$  meeting the first line at  $o$  as shown in Fig. 3.18 (b).

4. Now the force ( $P$ ) required on the wedge to raise the load will be given by  $mo$ . to the scale.

**EXAMPLE 3.8** A block weighing 1500 N, overlying a  $10^\circ$  wedge on a horizontal floor and leaning against a vertical wall, is to be raised by applying a horizontal force to the

wedge. Assuming the coefficient of friction between all the surface in contact to be 0.3, Determine the minimum horizontal force required to raise the block.

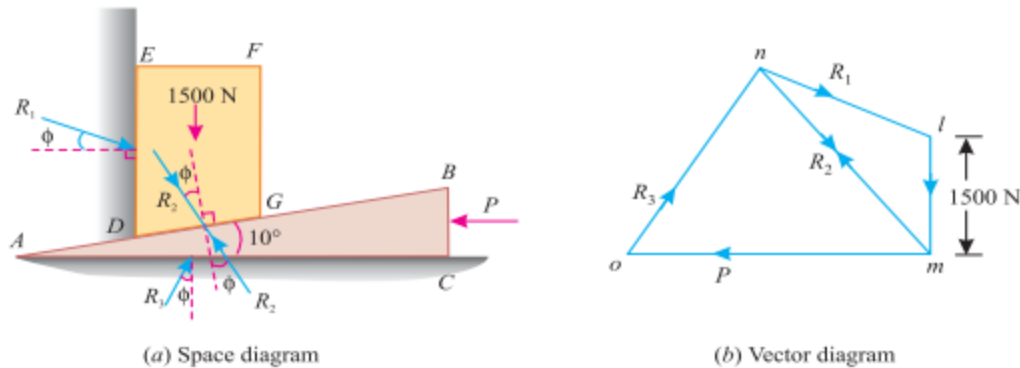

Fig 3.19

Solution. Given: Weight of the block ( $W$ ) = 1500 N; Angle of the wedge ( $\alpha$ ) =  $10^\circ$  and coefficient of friction between all the four surfaces of contact ( $\mu$ ) = 0.3 =  $\tan \phi$  or  $\phi = 16.7^\circ$ .

$P$  = Minimum horizontal force required to raise the block.

The example may be solved graphically or analytically. But we shall solve it by both the method

### Graphical method

1. First of all, draw the space diagram for the block DEFG and the wedge ABC as shown in Fig.3.19 (a). Now draw reactions  $R_1$ ,  $R_2$  and  $R_3$  at angles of  $\phi$  (i.e.  $16.7^\circ$  with normal to the faces DE, AB and AC respectively).

2. Take some suitable point I, and draw vertical line Im equal to 1500 N to some suitable scale (representing the weight of the block). Through I, draw a line parallel to the reaction  $R_1$ . Similarly, through m draw another line parallel to the reaction  $R_2$  meeting the first line at n.

3. Now through m, draw a horizontal line (representing the horizontal force P). Similarly, through n draw a line parallel to the reaction  $R_3$  meeting the first line at O as shown in Fig.(b).

4. Now measuring mo to the scale, we find that the required horizontal force

$$P = 1420 \text{ N. Ans.}$$

### Analytical method:

1. First of all, consider the equilibrium of the body DEFG. And resolve the forces  $W$ ,  $R_1$  and  $R_2$  horizontally as well as vertically.

2. Now consider the equilibrium of the wedge ABC. And resolve the forces  $P$ ,  $R_2$  and  $R_3$  horizontally as well as vertically.

### Solution.

Given: Weight of the block ( $W$ ) = 1500 N; Angle of the wedge ( $\alpha$ ) =  $10^\circ$  and

coefficient of friction between all the four surfaces of contact ( $\mu$ ) = 0.3 =  $\tan \phi$  or  $\phi = 16.7^\circ$ .  
 First of all, consider the equilibrium of the block. We know that it is in equilibrium under the action of the following forces as shown in Fig. (a).

1. Its own weight 1500 N acting downwards.
2. Reaction  $R_1$  on the face DE.
3. Reaction  $R_2$  on the face DG of the block.

Resolving the forces horizontally,

$$R_1 \cos (16.7^\circ) = R_2 \sin (10^\circ + 16.7^\circ) = R_2 \sin 26.7^\circ$$

$$R_1 \times 0.9578 = R_2 \times 0.4493$$

$$\text{or } R_2 = 2.132 R_1$$

and now resolving the forces vertically,

$$R_1 \times \sin (16.7^\circ) + 1500 = R_2 \cos (10^\circ + 16.7^\circ) = R_2 \cos 26.7^\circ$$

$$R_1 \times 0.2874 + 1500 = R_2 \times 0.8934 = (2.132 R_1) 0.8934$$

$$= 1.905 R_1 \dots (R_2 = 2.132 R_1)$$

$$R_1(1.905 - 0.2874) = 1500$$

$$R_1 = \frac{1500}{1.6176} = 927.3 \text{ N}$$

$$\text{Again } R_2 = 2.132 R_1 = 2.132 \times 927.3 = 1977 \text{ N}$$

Now consider the equilibrium of the wedge. We know that it is in equilibrium under the action of the following forces as shown in Fig.(b).

1. Reaction  $R_2$  of the block on the wedge.
2. Force (P) acting horizontally, and
3. Reaction  $R_3$  on the face AC of the wedge.

Resolving the forces vertically,

$$R_3 \cos 16.7^\circ = R_2 \cos (10^\circ + 16.7^\circ) = R_2 \cos 26.7^\circ$$

$$R_3 \times 0.9578 = R_2 \times 0.8934 = 1977 \times 0.8934 = 1766.2$$

$$\therefore R_3 = \frac{1766.2}{0.9578} = 1844 \text{ N.}$$

and now resolving the forces horizontally,

$$P = R_2 \sin (10^\circ + 16.7^\circ) + R_3 \sin 16.7^\circ = 1977 \sin 26.7^\circ + 1844 \sin 16.7^\circ \text{ N}$$

$$= (1977 \times 0.4493) + (1844 \times 0.2874) = 1418.3 \text{ N Ans.}$$

## EXERCISES

1. What do you understand by the term friction? Explain clearly why it comes into play?
2. How will you distinguish between static friction and dynamic friction?
3. State the laws of friction.
4. Explain the term angle of friction.
5. Define coefficient of friction and limiting friction.
6. What is angle of repose?
7. An inclined plane as shown in Fig. is used to unload slowly a body weighing 400 N from a truck 1.2 m high into the ground. The coefficient of friction between the underside of the body and the plank is 0.3. State whether it is necessary to push the body down the plane or hold it back from sliding down. What minimum force is required parallel to the plane for this purpose? **Ans. 71.2N**

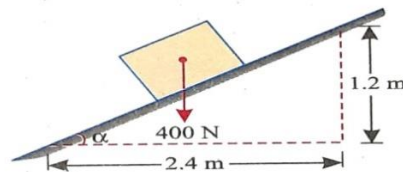

8. An object of weight 100 N is kept in position on a plane inclined  $30^\circ$  to the horizontal by a horizontally applied force (F). If the coefficient of friction of the surface of the inclined plane is 0.25, determine the minimum magnitude of the force (F). **Ans. 28.67 N**
9. The upper half of an inclined having inclination  $\theta$  with the horizontal is smooth, while the lower half is rough as shown in Fig. If a body of weight W slides down from rest at the top, again comes to rest at the bottom of the plane, then determine the value of coefficient of friction for the lower half of the plane. **Ans.  $\mu = 2 \tan \theta$**

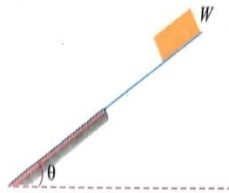

10. A uniform ladder of 4 m length rests against a vertical wall with which it makes an angle of  $45^\circ$ . The coefficient of friction between the ladder and the wall is 0.4 and that between ladder and the floor is 0.5. If a man, whose weight is one-half of that of the ladder ascends it, how high will it be when the ladder slips? **Ans. 3m**

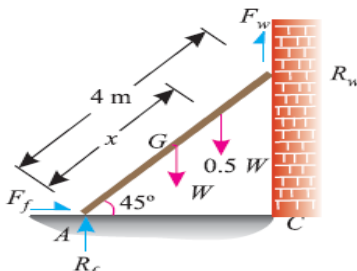

11. A  $15^\circ$  wedge (A) has to be driven for tightening a body (B) loaded with 1000N weight as shown in Fig.

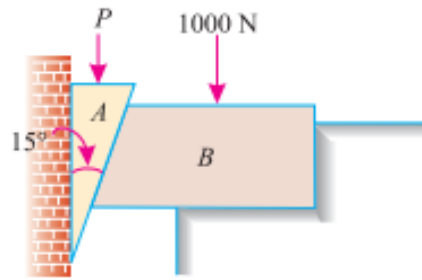

If the angle of friction for all the surfaces is  $14^\circ$ , find graphically the force (P), which should be applied to the wedge. Also check the answer analytically. **Ans. 232 N**

12. Two blocks A and B of weights 1 kN and 2 kN respectively are in equilibrium position as shown in Fig. If the coefficient of friction between the two blocks as well as the block B and the floor is 0.3, find the force (P) required to move the block B. **Ans. 1.11 kN**

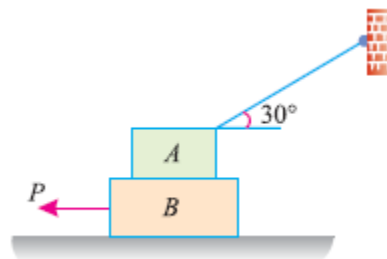

## CHAPTER 4: CENTROID AND MOMENT OF INERTIA

### LEARNING OUTCOMES:

On completion of the subject, the student will be able to:

- Understand the concept of centroid and moment of inertia(M.I)
- Calculate centroid and M.I of various Geometrical shapes
- Distinguish between centroid and Centre of Gravity (C.G).
- Understand the concept of parallel axis and perpendicular axes theorem.

### 4.1. CENTROID

#### INTRODUCTION:

A body may be considered to be made up of a number of minute particles having weights having weights  $w_1, w_2, w_3, \dots, w_n$  which are attracted towards the centre of body. As the particles are considered negligible in comparison to body, all the forces are considered to be parallel to each other. The resultant of all these forces acting at a point known as Centre of Gravity (C.G).

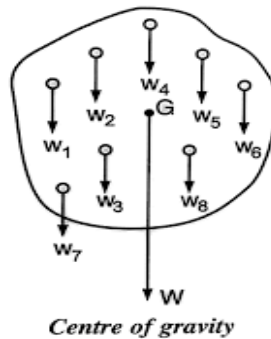

Fig . 4.1.

#### CENTRE OF GRAVITY (C.G):

Centre of Gravity of a body is a fixed point with respect to the body, through which resultant of weights of all particles of the body passes, at any plane .

#### CENTROID DEFINITION:

Centroid is the centre point or geometric centre of a plane figure like triangle, circle, quadrilateral, etc. The method of finding centroid is same as finding C.G of a body.

#### METHODS FOR CENTRE OF GRAVITY

The centre of gravity (or centroid) may be found out by any one of the following two methods:

1. By geometrical considerations
2. By moments
3. By graphical method



## CENTRE OF GRAVITY BY MOMENTS

Consider a body of mass  $M$  whose centre of gravity is required to be found out. Divide the body into small masses, whose centers of gravity are known as shown in Fig. 6.9. Let  $m_1, m_2, m_3, \dots$ ; etc. be the masses of the particles and  $(x_1, y_1), (x_2, y_2), (x_3, y_3), \dots$  be the co-ordinates of the centers of gravity from a fixed point  $O$  as shown in Fig. 4.2

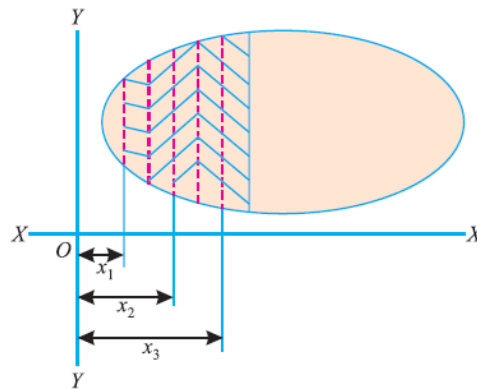

Fig 4.2

Let  $\bar{x}$  and  $\bar{y}$  be the co-ordinates of the centre of gravity of the body. From the principle of moments, we know that

$$M \bar{x} = m_1 x_1 + m_2 x_2 + m_3 x_3 + \dots$$

$$\bar{x} = \frac{\sum mx}{M}$$

$$\bar{y} = \frac{\sum my}{M},$$

$$M = m_1 + m_2 + m_3 + \dots$$

## AXIS OF REFERENCE

The centre of gravity of a body is always calculated with reference to some assumed axis known as axis of reference. The axis of reference, of plane figures, is generally taken as the lowest line of the figure for calculating  $y$  and the left line of the figure for calculating  $\bar{x}$ .

## CENTRE OF GRAVITY OF PLANE FIGURES

The centre of area of plane geometrical figures is known as centroid, and coincides with the centre of gravity of the figure. It is a common practice to use centre of gravity for centroid and vice versa.

Let  $\bar{x}$  and  $\bar{y}$  be the co-ordinates of the centre of gravity with respect to some axis of reference, then

$$\bar{x} = \frac{a_1 x_1 + a_2 x_2 + a_3 x_3 + \dots}{a_1 + a_2 + a_3}$$

$$\bar{y} = \frac{a_1 y_1 + a_2 y_2 + a_3 y_3 + \dots}{a_1 + a_2 + a_3 + \dots}$$

where  $a_1, a_2, a_3, \dots$  etc., are the areas into which the whole figure is divided  $x_1, x_2, x_3, \dots$  etc., are the respective co-ordinates of the areas  $a_1, a_2, a_3, \dots$  on X-X axis with respect to same axis of reference.  $y_1, y_2, y_3, \dots$  etc., are the respective co-ordinates of the areas  $a_1, a_2, a_3, \dots$  on Y-Y axis with respect to same axis of the reference. The distances in one direction are taken as positive and those in the opposite directions must be taken as negative.

**Case1:** Consider the triangle ABC of base 'b' and height 'h'. Determine the distance of centroid from the base

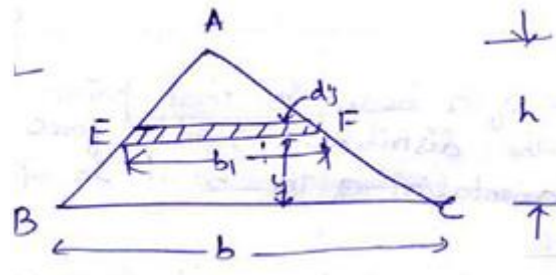

Fig 4.3

Let us consider an elemental strip of width 'b<sub>1</sub>' and thickness 'dy'.

$$\Delta AEF \sim \Delta ABC$$

$$\therefore \frac{b_1}{b} = \frac{h-y}{h}$$

$$\Rightarrow b_1 = b \left( \frac{h-y}{h} \right)$$

$$\Rightarrow b_1 = b \left( 1 - \frac{y}{h} \right)$$

$$\begin{aligned} \text{Area of element EF (dA)} &= b_1 \times dy \\ &= b \left( 1 - \frac{y}{h} \right) dy \end{aligned}$$

$$\begin{aligned}
 y_c &= \frac{\int y \cdot dA}{A} \\
 &= \frac{\int_0^h y b \left(1 - \frac{y}{h}\right) dy}{\frac{1}{2} b h} \\
 &= \frac{b \left[ \frac{y^2}{2} - \frac{y^3}{3h} \right]_0^h}{\frac{1}{2} b h} \\
 &= \frac{2}{h} \left[ \frac{h^2}{2} - \frac{h^3}{3} \right] \\
 &= \frac{2}{h} \times \frac{h^2}{6} \\
 &= \frac{h}{3}
 \end{aligned}$$

Therefore  $y_c$  is at a distance of  $h/3$  from base.

Case2: Consider a semi-circle of radius  $R$ . Determine its distance from diametral axis.

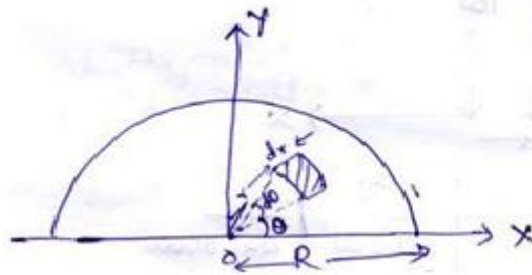

Fig 4.4

Due to symmetry, centroid ' $y_c$ ' must lie on Y-axis.

Consider an element at a distance ' $r$ ' from centre ' $o$ ' of the semicircle with radial width  $dr$ .

Area of element =  $(r \cdot d\theta) \times dr$

Moment of area about =  $\int y \cdot dA$

$$\begin{aligned}
&= \int_0^\pi \int_0^R (r \cdot d\theta) \cdot dr \times (r \cdot \sin \theta) \\
&= \int_0^\pi \int_0^R r^2 \sin \theta \cdot dr \cdot d\theta \\
&= \int_0^\pi \left( \int_0^R r^2 \cdot dr \right) \cdot \sin \theta \cdot d\theta \\
&= \int_0^\pi \left[ \frac{r^3}{3} \right]_0^R \cdot \sin \theta \cdot d\theta \\
&= \int_0^\pi \frac{R^3}{3} \cdot \sin \theta \cdot d\theta \\
&= \frac{R^3}{3} [-\cos \theta]_0^\pi \\
&= \frac{R^3}{3} [1 + 1] \\
&= \frac{2}{3} R^3
\end{aligned}$$

$$y_c = \frac{\text{Moment of area}}{\text{Total area}}$$

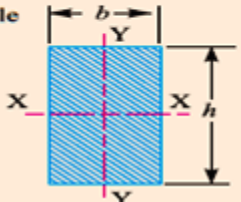
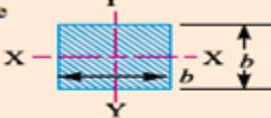
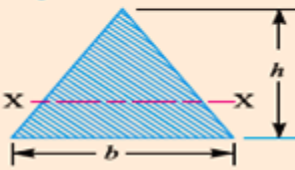

## CENTROID OF VARIOUS CROSSECTIONS

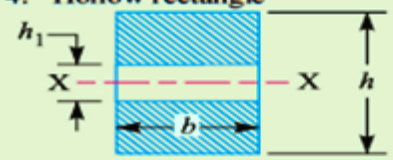
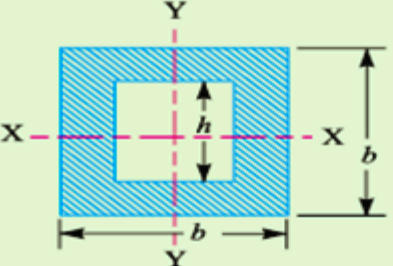
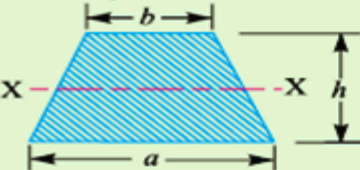
Section	Area (A)	Moment of inertia (I)	*Distance from the neutral axis to the extreme fibre (y)
1. Rectangle 	$bh$	$I_{xx} = \frac{b \cdot h^3}{12}$ $I_{yy} = \frac{h \cdot b^3}{12}$	$\frac{h}{2}$  $\frac{b}{2}$
2. Square 	$b^2$	$I_{xx} = I_{yy} = \frac{b^4}{12}$	$\frac{b}{2}$
3. Triangle 	$\frac{bh}{2}$	$I_{xx} = \frac{b \cdot h^3}{36}$	$\frac{h}{3}$

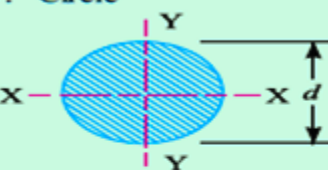
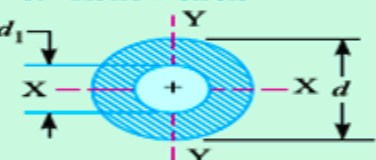
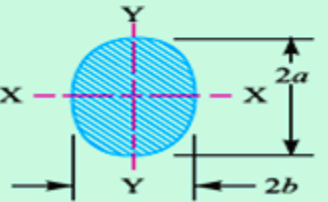
<p>4. Hollow rectangle</p> 	$b(h - h_1)$	$I_{xx} = \frac{b}{12}(h^3 - h_1^3)$	$\frac{h}{2}$
<p>5. Hollow square</p> 	$b^2 - h^2$	$I_{xx} = I_{yy} = \frac{b^4 - h^4}{12}$	$\frac{b}{2}$
<p>6. Trapezoidal</p> 	$\frac{a + b}{2} \times h$	$I_{xx} = \frac{h^2(a^2 + 4ab + b^2)}{36(a + b)}$	$\frac{a + 2b}{3(a + b)} \times h$

Section	(A)	(I)	(y)
<p>7. Circle</p> 	$\frac{\pi}{4} \times d^2$	$I_{xx} = I_{yy} = \frac{\pi d^4}{64}$	$\frac{d}{2}$
<p>8. Hollow circle</p> 	$\frac{\pi}{4}(d^2 - d_1^2)$	$I_{xx} = I_{yy} = \frac{\pi}{64}(d^4 - d_1^4)$	$\frac{d}{2}$
<p>9. Elliptical</p> 	$\pi ab$	$I_{xx} = \frac{\pi}{4} \times a^3 b$ $I_{yy} = \frac{\pi}{4} \times ab^3$	$a$ $b$

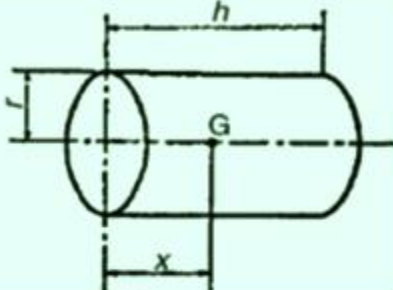
## CENTROIDS OF SOLID BODIES

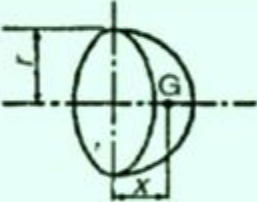
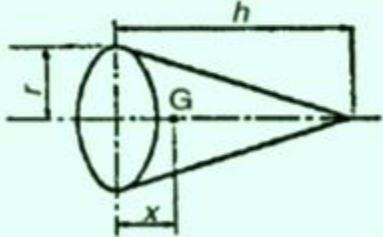
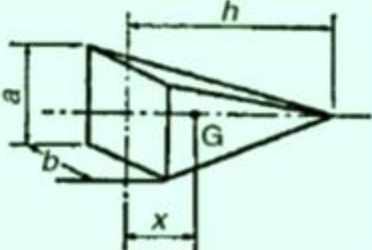
<i>Shape of volume</i>	Position of centre of gravity (G) at distance $x$ from the end shown	<i>Volume</i>
Cylinder 	$h/2$	$\pi r^2 h$
Sphere 	$r$	$\frac{4\pi r^3}{3}$
Hemisphere 	$3r/8$	$\frac{2\pi r^3}{3}$
Cone 	$h/4$	$\frac{\pi r^2 h}{3}$
Pyramid 	$h/4$	$\frac{abh}{3}$

## CENTRE OF GRAVITY OF SYMMETRICAL SECTIONS

Section, whose centre of gravity is required to be found out, and is symmetrical about X-X axis or Y-Y axis the procedure for calculating the centre of gravity of the body is to calculate either  $\bar{x}$  or  $\bar{y}$ . This is due to the reason that the centre of gravity of the body will lie on the axis of symmetry.

**Example 4.1.** Find the centre of gravity of a channel section 100 mm × 50 mm × 15 mm.

**Solution:** As the section is symmetrical about X-X axis, therefore its centre of gravity will lie on this axis. Now split up the whole section into three rectangles ABFJ, EGKJ and CDHK as shown in Fig 4.5. Let the face AC be the axis of reference.

(i) Rectangle ABFJ

$$a_1 = 50 \times 15 = 750 \text{ mm}^2$$

and 
$$x_1 = \frac{50}{2} = 25 \text{ mm}$$

(ii) Rectangle EGKJ

$$a_2 = (100 - 30) \times 15 = 1050 \text{ mm}^2$$

and 
$$x_2 = \frac{15}{2} = 7.5 \text{ mm}$$

(iii) Rectangle CDHK

$$a_3 = 50 \times 15 = 750 \text{ mm}^2$$

and 
$$x_3 = \frac{50}{2} = 25 \text{ mm}$$

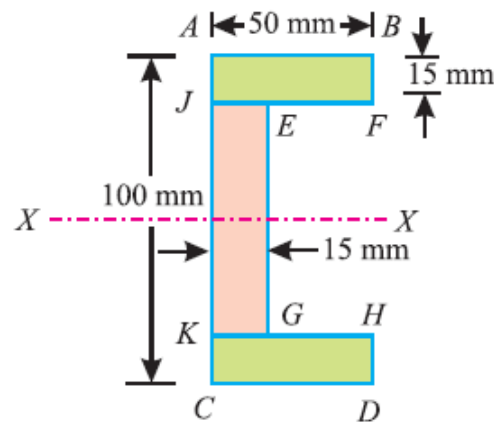

Fig 4.5

We know that distance between the centre of gravity of the section and left face of the section AC,

$$\begin{aligned} \bar{x} &= \frac{a_1 x_1 + a_2 x_2 + a_3 x_3}{a_1 + a_2 + a_3} \\ &= \frac{(750 \times 25) + (1050 \times 7.5) + (750 \times 25)}{750 + 1050 + 750} = 17.8 \text{ mm} \quad \text{Ans.} \end{aligned}$$

**Example 4.2** An I-section has the following dimensions in mm units:

**Bottom flange = 300 × 100**

**Top flange = 150 × 50**

**Web = 300 × 50**

**Determine mathematically the position of centre of gravity of the section.**

**Solution.** As the section is symmetrical about Y-Y axis, bisecting the web, therefore its centre of gravity will lie on this axis. Now split up the section into three rectangles as shown in Fig. 4.6

Let bottom of the bottom flange be the axis of reference.

(i) *Bottom flange*

$$a_1 = 300 \times 100 = 30\,000 \text{ mm}^2$$

and  $y_1 = \frac{100}{2} = 50 \text{ mm}$

(ii) *Web*

$$a_2 = 300 \times 50 = 15\,000 \text{ mm}^2$$

and  $y_2 = 100 + \frac{300}{2} = 250 \text{ mm}$

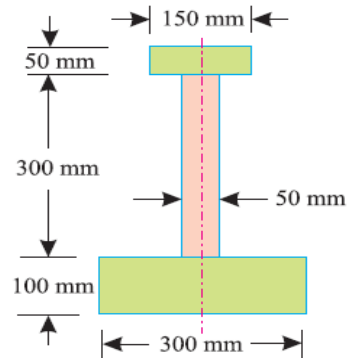

Fig 4.6

(iii) *Top flange*

$$a_3 = 150 \times 50 = 7500 \text{ mm}^2$$

and  $y_3 = 100 + 300 + \frac{50}{2} = 425 \text{ mm}$

We know that distance between centre of gravity of the section and bottom of the flange,

$$\begin{aligned} \bar{y} &= \frac{a_1 y_1 + a_2 y_2 + a_3 y_3}{a_1 + a_2 + a_3} \\ &= \frac{(30\,000 \times 50) + (15\,000 \times 250) + (7500 \times 425)}{30\,000 + 15\,000 + 7500} = 160.7 \text{ mm} \quad \text{Ans.} \end{aligned}$$

**Example 4.3** Find the centroid of the T-section as shown in figure 4.7 from the bottom

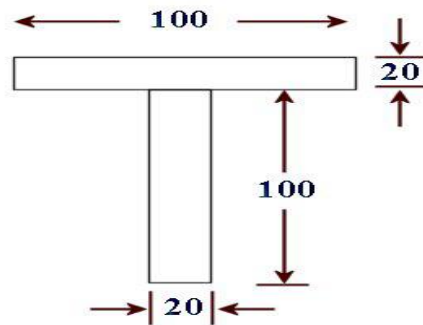

Fig 4.7



Soln:

Area ( $A_i$ )	$x_i$	$y_i$	$A_i x_i$	$A_i y_i$
2000	0	110	10,000	22,0000
2000	0	50	10,000	10,0000
4000			20,000	32,0000

$$y_c = \frac{\sum A_i y_i}{A_i} = \frac{A_1 y_1 + A_2 y_2}{A_1 + A_2} = \frac{32,0000}{4000} = 80$$

Due to symmetry, the centroid lies on Y-axis and it is at distance of 80 mm from the bottom.

**Example 4.3 Determine the centroid of the following figure.**

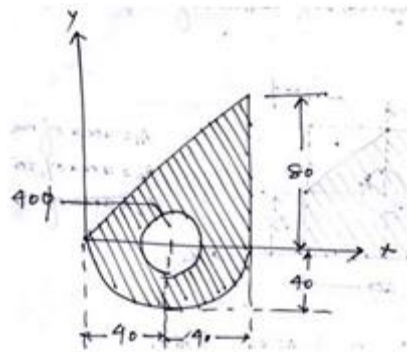

Fig 4.8

Soln:

$$A_1 = \text{Area of triangle} = \frac{1}{2} \times 80 \times 80 = 3200m^2$$

$$A_2 = \text{Area of semicircle} = \frac{\pi d^2}{8} - \frac{\pi R^2}{2} = 2513.274m^2$$

$$A_3 = \text{Area of semicircle} = \frac{\pi D^2}{2} = 1256.64m^2$$

Area ( $A_i$ )	$x_i$	$y_i$	$A_i x_i$	$A_i y_i$
3200	$2 \times (80/3) = 53.33$	$80/3 = 26.67$	170656	85344
2513.274	40	$\frac{-4 \times 40}{3\pi} = -16.97$	100530.96	-42650.259
1256.64	40	0	50265.6	0

$$x_c = \frac{A_1 x_1 + A_2 x_2 - A_3 x_3}{A_1 + A_2 + A_3} = 49.57 \text{ mm}$$

$$y_c = \frac{A_1 y_1 + A_2 y_2 - A_3 y_3}{A_1 + A_2 - A_3} = 9.58 \text{ mm}$$

**Example 4.4** A body consists of a right circular solid cone of height 40 mm and radius 30 mm placed on a solid hemisphere of radius 30 mm of the same material. Find the position of centre of gravity of the body.

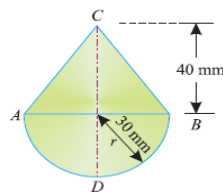

Fig 4.9

**Solution.** As the body is symmetrical about Y-Y axis, therefore its centre of gravity will lie on this axis as shown in Fig. Let bottom of the hemisphere (D) be the point of reference.

Hemisphere

$$v_1 = \frac{2\pi}{3} \times r^3 = \frac{2\pi}{3} (30)^3 \text{ mm}^3$$

$$= 18\,000 \pi \text{ mm}^3$$

$$y_1 = \frac{5r}{8} = \frac{5 \times 30}{8} = 18.75 \text{ mm}$$

Right circular cone

$$v_2 = \frac{\pi}{3} \times r^2 \times h = \frac{\pi}{3} \times (30)^2 \times 40 \text{ mm}^3$$

$$= 12\,000 \pi \text{ mm}^3$$

$$y_2 = 30 + \frac{40}{4} = 40 \text{ mm}$$

Distance between centre of gravity of the body and bottom of hemisphere D,

$$\bar{y} = \frac{v_1 y_1 + v_2 y_2}{v_1 + v_2} = \frac{(18\,000 \pi \times 18.75) + (12\,000 \pi \times 40)}{18\,000 \pi + 12\,000 \pi} \text{ mm}$$

$$= 27.3 \text{ mm} \quad \text{Ans.}$$

### CENTRE OF GRAVITY OF UNSYMMETRICAL SECTIONS

Sometimes, the given section, whose centre of gravity is required to be found out, is not symmetrical either about X-X axis or Y-Y axis. In such cases, we have to find out both the values of  $\bar{x}$  and  $\bar{y}$

**Example 4.5. Find the centroid of an unequal angle section 100 mm × 80 mm × 20 mm.**

**Solution :**

As the section is not symmetrical about any axis, therefore we have to find out the values of  $x$  and  $y$  for the angle section. Split up the section into two rectangles as shown in Fig.4.10

Let left face of the vertical section and bottom face of the horizontal section be axes of reference.

(i) *Rectangle 1*

$$a_1 = 100 \times 20 = 2000 \text{ mm}^2$$

$$x_1 = \frac{20}{2} = 10 \text{ mm}$$

and  $y_1 = \frac{100}{2} = 50 \text{ mm}$

(ii) *Rectangle 2*

$$a_2 = (80 - 20) \times 20 = 1200 \text{ mm}^2$$

$$x_2 = 20 + \frac{60}{2} = 50 \text{ mm}$$

and  $y_2 = \frac{20}{2} = 10 \text{ mm}$

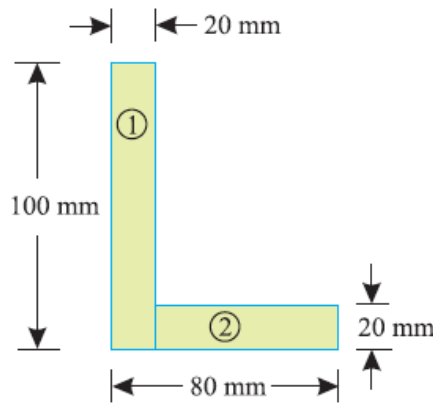

Fig. 4.10

We know that distance between centre of gravity of the section and left face,

$$\bar{x} = \frac{a_1 x_1 + a_2 x_2}{a_1 + a_2} = \frac{(2000 \times 10) + (1200 \times 50)}{2000 + 1200} = 25 \text{ mm} \quad \text{Ans.}$$

Similarly, distance between centre of gravity of the section and bottom face,

$$\bar{y} = \frac{a_1 y_1 + a_2 y_2}{a_1 + a_2} = \frac{(2000 \times 50) + (1200 \times 10)}{2000 + 1200} = 35 \text{ mm} \quad \text{Ans.}$$

**Example 4.6. A semicircle of 90 mm radius is cut out from a trapezium as shown in Fig 4.11 .Find the position of the centre of gravity of the figure.**

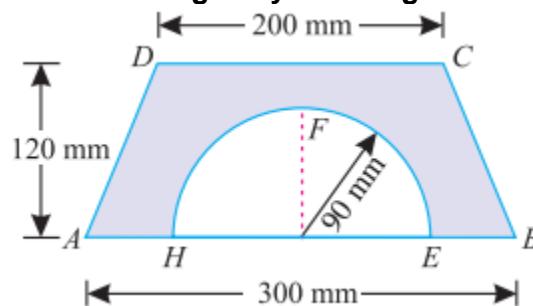

Fig 4.11

**Solution.** As the section is symmetrical about Y-Y axis, therefore its centre of gravity will lie on this axis. Now consider two portions of the figure viz., trapezium ABCD and semicircle EFH. Let base of the trapezium AB be the axis of reference.

(i) *Trapezium ABCD*

$$a_1 = 120 \times \frac{200 + 300}{2} = 30\,000 \text{ mm}^2$$

and 
$$y_1 = \frac{120}{3} \times \left( \frac{300 + 2 \times 200}{300 + 200} \right) = 56 \text{ mm}$$

(ii) *Semicircle*

$$a_2 = \frac{1}{2} \times \pi r^2 = \frac{1}{2} \times \pi \times (90)^2 = 4050\pi \text{ mm}^2$$

and 
$$y_2 = \frac{4r}{3\pi} = \frac{4 \times 90}{3\pi} = \frac{120}{\pi} \text{ mm}$$

We know that distance between centre of gravity of the section and AB

$$\begin{aligned} \bar{y} &= \frac{a_1 y_1 - a_2 y_2}{a_1 - a_2} = \frac{(30\,000 \times 56) - \left( 4050\pi \times \frac{120}{\pi} \right)}{30\,000 - 4050\pi} \text{ mm} \\ &= 69.1 \text{ mm} \quad \text{Ans.} \end{aligned}$$

## 4.2 MOMENT OF INERTIA:

### INTRODUCTION:

Moment of a force (P) about a point, is the product of the force and perpendicular distance (x) between the point and the line of action of the force (i.e. P.x).

If this moment is again multiplied by the perpendicular distance (x) between the point and the line of action of the force i.e. P.x(x) = P $x^2$ , then this quantity is called **moment of inertia**.

### CALCULATION OF MOMENT OF INERTIA BY INTEGRATION METHOD:

The moment of inertia of an area may be found out by the method of integration:

Consider a plane figure, whose moment of inertia is required to be found out about X-X axis and Y-Y axis as shown in Fig 4.12. Let us divide the whole area into a no. of strips. Consider one of these strips.

Let dA = Area of the strip

x = Distance of the centre of gravity of the strip on X-X axis and

y = Distance of the centre of gravity of the strip on Y-Y axis.

We know that the moment of inertia of the strip about Y-Y axis = dA.x<sup>2</sup>

Now the moment of inertia of the whole area may be found out by integrating above equation.  
i.e.,

$$I_{YY} = \Sigma dA \cdot x^2$$

Similarly

$$I_{XX} = \Sigma dA \cdot y^2$$

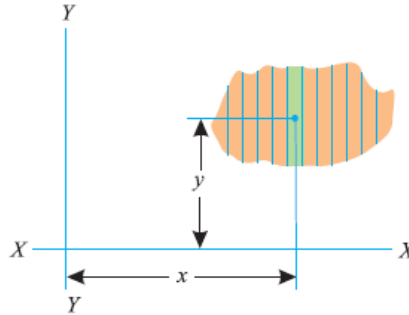

Fig 4.12

**Unit:** It depends on units of area and length

If area= $m^2$ , length = $m$  then,  $M.I=m^4$

If area= $mm^2$ , length= $mm$  then,  $M.I=mm^4$

### THEOREM OF PERPENDICULAR AXIS

If  $I_{XX}$  and  $I_{YY}$  be the moments of inertia of a plane section about two perpendicular axis meeting at O, the moment of inertia  $I_{ZZ}$  about the axis Z-Z, perpendicular to the plane and passing through the intersection of X-X and Y-Y is given by:

$$I_{ZZ} = I_{XX} + I_{YY}$$

**Proof:**

Consider a small lamina (P) of area  $da$  having co-ordinates as  $x$  and  $y$  along OX and OY two mutually perpendicular axes on a plane section as shown in Fig 4.13

Now consider a plane OZ perpendicular to OX and OY.

Let ( $r$ ) be the distance of the lamina (P) from Z-Z axis such that

$$OP = r.$$

From the geometry of the figure, we find that

$$r^2 = x^2 + y^2$$

We know that the moment of inertia of the lamina P about X-X axis,

$$I_{XX} = da \cdot y^2 \dots [I = \text{Area} \times (\text{Distance})^2]$$

Similarly,

$$I_{YY} = da \cdot x^2$$

$$\begin{aligned} \text{And } I_{ZZ} &= da \cdot r^2 = da (x^2 + y^2) \dots (r^2 = x^2 + y^2) \\ &= da \cdot x^2 + da \cdot y^2 = I_{YY} + I_{XX} \end{aligned}$$

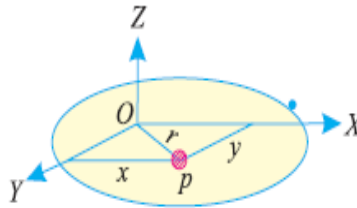

Fig 4.13

### THEOREM OF PARALLEL AXIS

It states, If the moment of inertia of a plane area about an axis through its centre of gravity is denoted by  $I_G$ , then moment of inertia of the area about any other axis AB, parallel to the first, and at a distance  $h$  from the centre of gravity is given by:

$$I_{AB} = I_G + ah^2$$

Where  $I_{AB}$  = Moment of inertia of the area about an axis AB,

$I_G$  = Moment of Inertia of the area about its centre of gravity

$a$  = Area of the section, and

$h$  = Distance between centre of gravity of the section and axis AB.

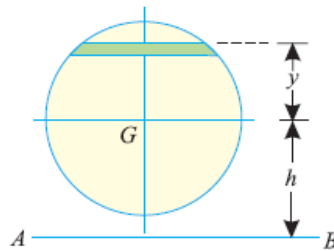

Fig 4.14

### Proof

Consider a strip of a circle, whose moment of inertia is required to be found out about a line AB as shown in Fig.4.14

Let  $\delta a$  = Area of the strip

$y$  = Distance of the strip from the centre of gravity the section and

$h$  = Distance between centre of gravity of the section and the axis AB.

Moment of inertia of the whole section about an axis passing through the centre of gravity of the section =  $\sum \delta a \cdot y^2$

and moment of inertia of the whole section about an axis passing through its centre of gravity,

$$I_G = \sum \delta a \cdot y^2$$

Moment of inertia of the section about the axis AB,

$$\begin{aligned} I_{AB} &= \sum \delta a (h + y)^2 = \sum \delta a (h^2 + y^2 + 2 h y) \\ &= (\sum h^2 \cdot \delta a) + (\sum y^2 \cdot \delta a) + (\sum 2 h y \cdot \delta a) \\ &= a h^2 + I_G + 0 \\ &= a h^2 + I_G \end{aligned}$$

### MOMENT OF INERTIA OF A RECTANGULAR SECTION

Consider a rectangular section ABCD as shown in Figure 4.15 whose moment of inertia is required to be found out.

Let  $b$  = Width of the section and

$d$  = Depth of the section.

Now consider a strip PQ of thickness  $dy$  parallel to X-X axis and at a distance  $y$  from it as shown in the figure

∴ Area of the strip =  $b \cdot dy$

We know that moment of inertia of the strip about X-X axis, = Area  $\times y^2 = (b \cdot dy) y^2 = b \cdot y^2 \cdot dy$

Now moment of inertia of the whole section may be found out by integrating the above equation for the whole length of the lamina i.e. from  $-d/2$  to  $d/2$ ,

$$I_{xx} = \int_{-\frac{d}{2}}^{+\frac{d}{2}} b \cdot y^2 \cdot dy = b \int_{-\frac{d}{2}}^{+\frac{d}{2}} y^2 \cdot dy$$

$$= b \left[ \frac{y^3}{3} \right]_{-\frac{d}{2}}^{+\frac{d}{2}} = b \left[ \frac{(d/2)^3}{3} - \frac{(-d/2)^3}{3} \right] = \frac{bd^3}{12}$$

$$I_{yy} = \frac{db^3}{12}$$

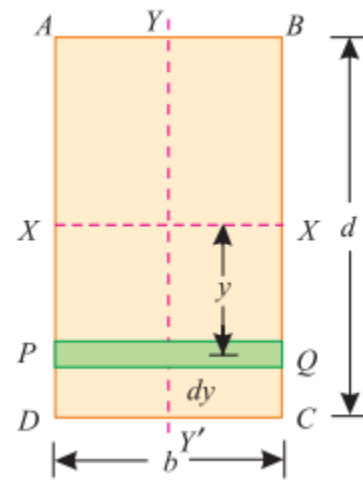

Fig4.15

### MOMENT OF INERTIA OF A HOLLOW RECTANGULAR SECTION

Consider a hollow rectangular section, in which ABCD is the main section and EFGH is the cut out section as shown in Fig 4.16

Let  $b$  = Breadth of the outer rectangle,

$d$  = Depth of the outer rectangle and

$b_1, d_1$  = Corresponding values for the cut out rectangle.

We know that the moment of inertia, of the outer rectangle ABCD about X-X axis =  $(bd^3)/12$

and moment of inertia of the cut out rectangle EFGH about X-X axis =  $(b_1d_1^3)/12$

∴ M.I. of the hollow rectangular section about X-X axis,

$$I_{xx} = \text{M.I. of rectangle } ABCD - \text{M.I. of rectangle } EFGH$$

$$= \frac{bd^3}{12} - \frac{b_1d_1^3}{12}$$

$$I_{yy} = \frac{db^3}{12} - \frac{d_1b_1^3}{12}$$

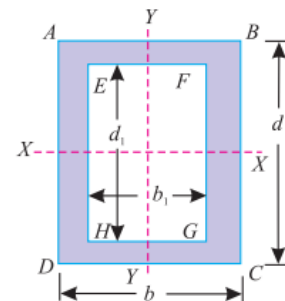

Fig 4.16

**Example 4.7 .Find the moment of inertia of a hollow rectangular section about its centre of gravity if the external dimensions are breadth 60 mm, depth 80 mm and internal dimensions are breadth 30 mm and depth 40 mm respectively.**

**Solution** Given: External breadth ( $b$ ) = 60 mm; External depth ( $d$ ) = 80 mm ; Internal breadth ( $b_1$ ) = 30 mm and internal depth ( $d_1$ ) = 40 mm. We know that moment of inertia of hollow rectangular section about an axis passing through its centre of gravity and parallel to X-X axis,

$$I_{XX} = \frac{bd^3}{12} - \frac{b_1d_1^3}{12} = \frac{60(80)^3}{12} - \frac{30(40)^3}{12} = 2400 \times 10^3 \text{ mm}^4 \quad \text{Ans.}$$

$$I_{YY} = \frac{db^3}{12} - \frac{d_1b_1^3}{12} = \frac{80(60)^3}{12} - \frac{40(30)^3}{12} = 1350 \times 10^3 \text{ mm}^4 \quad \text{Ans.}$$

### MOMENT OF INERTIA OF A CIRCULAR SECTION

Consider a circle ABCD of radius ( $r$ ) with centre O and XX' and Y-Y' be two axes of reference through O as shown in Fig.4.17

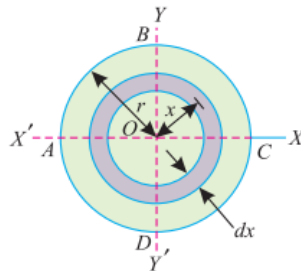

Fig 4.17

Now consider an elementary ring of radius  $x$  and thickness  $dx$ . Therefore area of the ring,  $da = 2\pi x \cdot dx$

and moment of inertia of ring, about X-X axis or Y-Y axis

$$\begin{aligned} &= \text{Area} \times (\text{Distance})^2 \\ &= 2\pi x \cdot dx \times x^2 \\ &= 2\pi x^3 \cdot dx \end{aligned}$$

Now moment of inertia of the whole section, about the central axis, can be found out by integrating the above equation for the whole radius of the circle i.e., from 0 to  $r$ .

$$I_{ZZ} = 2\pi \left[ \frac{x^4}{4} \right]_0^r = \frac{\pi}{2} (r)^4 = \frac{\pi}{32} (d)^4 \quad \dots \left( \text{substituting } r = \frac{d}{2} \right)$$

We know, from theorem of perpendicular axis,

$$\begin{aligned} I_{XX} + I_{YY} &= I_{ZZ} \\ I_{XX} = I_{YY} &= \frac{I_{ZZ}}{2} = \frac{1}{2} \times \frac{\pi}{32} (d)^4 = \frac{\pi}{64} (d)^4 \end{aligned}$$

**Example 4.8. Find the moment of inertia of a circular section of 50 mm diameter about an axis passing through its centre.**



**Solution** :Given: Diameter ( $d$ ) = 50 mm We know that moment of inertia of the circular section about an axis passing through its centre,

$$I_{XX} = \frac{\pi}{64} (d)^4 = \frac{\pi}{64} \times (50)^4 = 307 \times 10^3 \text{ mm}^4 \quad \text{Ans.}$$

### MOMENT OF INERTIA OF A HOLLOW CIRCULAR SECTION

Consider a hollow circular section as shown in Fig 4.18, whose moment of inertia is required to be found out.

Let  $D$  = Diameter of the main circle, and  
 $d$  = Diameter of the cut out circle.

We know that the moment of inertia of the main circle about X-X axis  $= \frac{\pi}{64} D^4$

and moment of inertia of the cut-out circle about X-X axis  $= \frac{\pi}{64} d^4$

Moment of inertia of the hollow circular section about X-X axis,

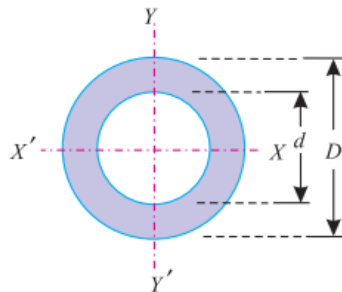

Fig 4.18

$I_{XX}$  = Moment of inertia of main circle – Moment of inertia of cut out circle,

$$= \frac{\pi}{64} D^4 - \frac{\pi}{64} d^4 = \frac{\pi}{64} (D^4 - d^4)$$

$$I_{YY} = \frac{\pi}{64} (D^4 - d^4)$$

**Example 4.9.** A hollow circular section has an external diameter of 80 mm and internal diameter of 60 mm. Find its moment of inertia about the horizontal axis passing through its centre.

**Solution.**  $D=80\text{mm}, d=60\text{mm}$

$$I_{XX} = \frac{\pi}{64} (D^4 - d^4) = \frac{\pi}{64} (80^4 - 60^4) = 1374 \times 10^3 \text{ mm}^4$$

### MOMENT OF INERTIA OF A COMPOSITE SECTION

The moment of inertia of a composite section may be found out by the following steps :

1. First of all, split up the given section into plane areas (*i.e.*, rectangular, triangular, circular etc., and find the centre of gravity of the section).
2. Find the moments of inertia of these areas about their respective centers of gravity.
3. Now transfer these moment of inertia about the required axis ( $AB$ ) by the Theorem of Parallel Axis, *i.e.*,  $I_{AB} = IG + ah^2$

where  $I_G$  = Moment of inertia of a section about its centre of gravity and parallel to the axis.

$a$  = Area of the section,

$h$  = Distance between the required axis and centre of gravity of the section.

4. The moments of inertia of the given section may now be obtained by the algebraic sum of the moment of inertia about the required axis.

### MOMENT OF INERTIA OF A TRIANGULAR SECTION

Consider a triangular section ABC whose moment of inertia is required to be found out.

Let  $b$  = Base of the triangular section and  
 $h$  = Height of the triangular section.

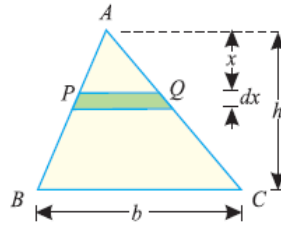

Fig 4.19

Consider a small strip PQ of thickness  $dx$  at a distance of  $x$  from the vertex A as shown in Fig. 4.19. From the geometry of the figure, we find that the two triangles APQ and ABC are similar. Therefore

$$\frac{PQ}{BC} = \frac{x}{h} \quad \text{or} \quad PQ = \frac{BC \cdot x}{h} = \frac{bx}{h}$$

We know that area of the strip  $PQ = \frac{bx}{h} dx$

and moment of inertia of the strip about the base BC = Area  $\times$  (Distance) $^2 = \frac{bx}{h} dx (h-x)^2 = \frac{bx}{h} (h-x)^2 dx$

Moment of inertia of the whole triangular section may be found out by integrating the above equation for the whole height of the triangle i.e., from 0 to  $h$ .

$$\begin{aligned} I_{BC} &= \int_0^h \frac{bx}{h} (h-x)^2 dx \\ &= \frac{b}{h} \int_0^h x (h^2 + x^2 - 2hx) dx \\ &= \frac{b}{h} \int_0^h (xh^2 + x^3 - 2hx^2) dx \\ &= \frac{b}{h} \left[ \frac{x^2 h^2}{2} + \frac{x^4}{4} - \frac{2hx^3}{3} \right]_0^h = \frac{bh^3}{12} \end{aligned}$$

We know that distance between centre of gravity of the triangular section and base BC,  $d = h/3$   
 Therefore, Moment of inertia of the triangular section about an axis through its centre of gravity and parallel to X-X axis,  $I_G = I_{BC} - ad^2$

$$= \frac{bh^3}{12} - \left( \frac{bh}{2} \right) \left( \frac{h}{3} \right)^2 = \frac{bh^3}{36}$$

**Example 4.10. A hollow triangular section shown in Fig is symmetrical about its vertical axis. Find the moment of inertia of the section.**

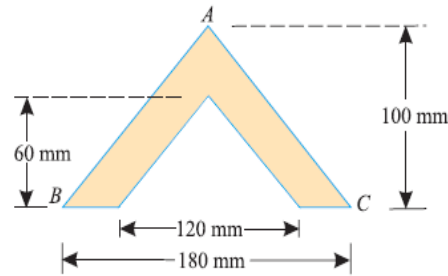

Fig 4.20

Solution.:

Given : Base width of main triangle (B) = 180 mm; Base width of cut out triangle (b) = 120 mm; Height of main triangle (H) = 100 mm and height of cut out triangle (h) = 60 mm.

Moment of Inertia about triangular section,

$$\frac{BH^3}{36} - \frac{bh^3}{36} = \frac{180 \times 100^3}{36} - \frac{120 \times 60^3}{36} = 5 \times 10^6 - 72 \times 10^4 = 4.28 \times 10^6 \text{ mm}^4$$

**Example 4.12 A hollow semicircular section has its outer and inner diameter of 200 mm and 120 mm respectively as shown in Fig. What is its moment of inertia about the base AB ?**

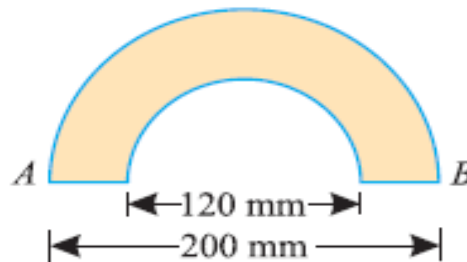

Fig 4.21

Solution .:

Given: Outer diameter (D) = 200 mm or Outer Radius (R) = 100 mm and inner diameter (d) = 120 mm or inner radius (r) = 60 mm.

We know that moment of inertia of the hollow semicircular section about the base AB,

$$I_{AB} = 0.393 (R^4 - r^4) = 0.393 [(100)^4 - (60)^4] = 34.21 \times 10^6 \text{ mm}^4 \text{ Ans}$$

## MOMENT OF INERTIA OF SOME GEOMETRIC SHAPES

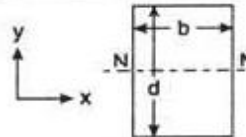
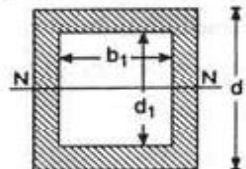
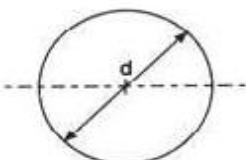
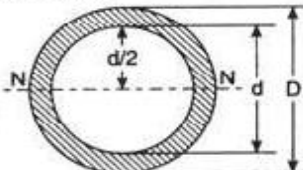
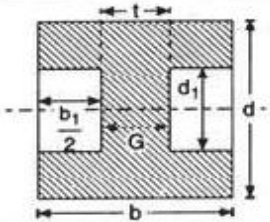
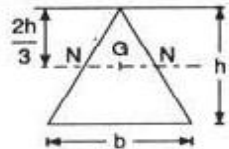
Type of section	Moment of Inertia	$y_{max}$	Section modulus (Z)
Rectangle or parallelogram 	$I_{xx} = \frac{bd^3}{12}$ $I_{yy} = \frac{db^3}{12}$	$\frac{d}{2}$  $\frac{b}{2}$	$Z_{xx} = \frac{bd^2}{6}$ $Z_{yy} = \frac{db^2}{6}$
Hollow rectangular section 	$I_{xx} = \frac{bd^3}{12} - \frac{b_1d_1^3}{12}$ $I_{yy} = \frac{db^3}{12} - \frac{d_1b_1^3}{12}$	$\frac{d}{2}$  $\frac{b}{2}$	$Z_{xx} = \frac{1}{6d}(bd^3 - b_1d_1^3)$ $Z_{yy} = \frac{1}{6b}(db^3 - d_1b_1^3)$
Circular section 	$I_{xx} = \frac{p}{64} d^4$ $I_{yy} = \frac{p}{64} d^4$	$\frac{d}{2}$  $\frac{d}{2}$	$Z_{xx} = \frac{p}{32} d^3$ $Z_{yy} = \frac{p}{32} d^3$
Hollow circular section 	$I_{xx} = I_{yy} = I$ $I_{yy} = \frac{p}{64} (D^4 - d^4)$	$\frac{D}{2}$	$Z_{xx} = Z_{yy} = Z$ $Z = \frac{p}{32D} (D^4 - d^4)$
I-section 	$I_{xx} = \frac{bd^3}{12} - \frac{b_1d_1^3}{12}$ $I_{yy} = \frac{db^3}{12} - \frac{d_1b_1^3}{12}$ or $I_{xx} = \frac{1}{12} (bd^3 - (b-t)d_1^3)$	$\frac{d}{2}$  $\frac{b}{2}$	$Z_{xx} = \frac{1}{6d}(bd^3 - b_1d_1^3)$ $Z_{yy} = \frac{1}{6b}(db^3 - d_1b_1^3)$
Triangle 	$I_G = \frac{bh^3}{36}$	$\frac{2}{3}h$	$Z_G = \frac{bh^2}{24}$

**Example 4.13.** An I-section is made up of three rectangles as shown in Fig 4.22. Find the moment of inertia of the section about the horizontal axis passing through the centre of gravity of the section.

**Solution.** First of all, let us find out centre of gravity of the section. As the section is symmetrical about Y-Y axis, therefore its centre of gravity will lie on this axis. Split up the whole section into

three rectangles 1, 2 and 3 as shown in Fig, Let bottom face of the bottom flange be the axis of reference.

(i) *Rectangle 1*

$$a_1 = 60 \times 20 = 1200 \text{ mm}$$

and  $y_1 = 20 + 100 + \frac{20}{2} = 130 \text{ mm}$

(ii) *Rectangle 2*

$$a_2 = 100 \times 20 = 2000 \text{ mm}^2$$

and  $y_2 = 20 + \frac{100}{2} = 70 \text{ mm}$

(iii) *Rectangle 3*

$$a_3 = 100 \times 20 = 2000 \text{ mm}^2$$

and  $y_3 = \frac{20}{2} = 10 \text{ mm}$

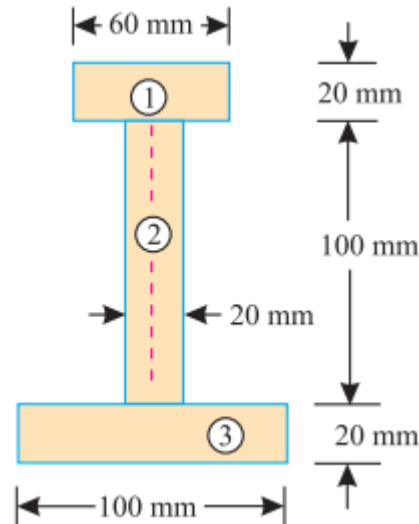

Fig 4.22

We know that the distance between centre of gravity of the section and bottom face

$$\bar{y} = \frac{a_1 y_1 + a_2 y_2 + a_3 y_3}{a_1 + a_2 + a_3} = \frac{(1200 \times 130) + (2000 \times 70) + (2000 \times 10)}{1200 + 2000 + 2000} \text{ mm}$$

$$= 60.8 \text{ mm}$$

We know that moment of inertia of rectangle (1) about an axis through its centre of gravity and parallel to X-X axis,

$$I_{G1} = \frac{60 \times (20)^3}{12} = 40 \times 10^3 \text{ mm}^4$$

and distance between centre of gravity of rectangle (1) and X-X axis

$$h_1 = 130 - 60.8 = 69.2 \text{ mm}$$

Moment of inertia of rectangle (1) about X-X axis

$$= I_{G1} + a_1 h_1^2 = (40 \times 10^3) + [1200 \times (69.2)^2] = 5786 \times 10^3 \text{ mm}^4$$

Similarly, moment of inertia of rectangle (2) about an axis through its centre of gravity and parallel to X-X axis,

$$I_{G2} = \frac{20 \times (100)^3}{12} = 1666.7 \times 10^3 \text{ mm}^4$$

and distance between centre of gravity of rectangle (2) and X-X axis,

$$h_2 = 70 - 60.8 = 9.2 \text{ mm}$$

Moment of inertia of rectangle (2) about X-X axis

$$= I_{G2} + a_2 h_2^2 = (1666.7 \times 10^3) + [2000 \times (9.2)^2] = 1836 \times 10^3 \text{ mm}^4$$

Now moment of inertia of rectangle (3) about an axis through its centre of gravity and parallel to X-X axis

$$I_{G3} = \frac{100 \times (20)^3}{12} = 66.7 \times 10^3 \text{ mm}^4$$

and distance between centre of gravity of rectangle (3) and X-X axis

$$h_3 = 60.8 - 10 = 50.8 \text{ mm}$$

Moment of inertia of rectangle (3) about X-X axis

$$= I_{G3} + a_3 h_3^2 = (66.7 \times 10^3) + [2000 \times (50.8)^2] = 5228 \times 10^3 \text{ mm}^4$$

Now moment of inertia of the whole section about X-X axis

$$I_{XX} = (5786 \times 10^3) + (1836 \times 10^3) + (5228 \times 10^3) = 12\,850 \times 10^3 \text{ mm}^4 \quad \text{Ans.}$$

## EXERCISE

1. How would you find out the moment of inertia of a plane area ?
2. What is Routh's rule for finding out the moment of inertia of an area ? Explain where it is used and why ?
3. State and prove the theorem of perpendicular axis applied to moment of inertia.
4. Prove the parallel axis theorem in the determination of moment of inertia of areas with the help of a neat sketch
5. Describe the method of finding out the moment of inertia of a composite section.
6. Derive an equation for moment of inertia of the following sections about centroidal axis: (a) a rectangular section, (b) a hollow rectangular section, (c) a circular section, and (d) a hollow circular section.
7. Find the moment of inertia of a T-section having flange and web both 120 mm × 30 mm about X-X axis passing through the centre of gravity of the section.  
**Ans.  $14\ 715 \times 10^3\ \text{mm}^4$**
8. Calculate the moment of inertia of an I-section having equal flanges 30 mm × 10 mm and web also 30 mm × 10 mm about an axis passing through its centre of gravity and parallel to X-X and Y-Y axes. **Ans.  $267.5 \times 10^3\ \text{mm}^4$ ;  $47 \times 10^3\ \text{mm}^4$**
9. Find the moment of inertia of the lamina with a circular hole of 30 mm diameter about the axis AB as shown in Fig below. **Ans.  $638.3 \times 10^3\ \text{mm}^4$**

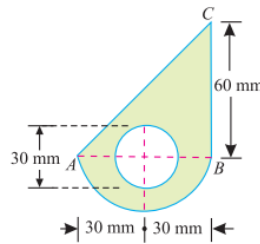

10. Find the moment of inertia of a rectangular section 60 mm wide and 40 mm deep about its centre of gravity. **Ans.  $I_{xx} = 320 \times 10^3\ \text{mm}^4$ ;  $I_{yy} = 720 \times 10^3\ \text{mm}^4$**
11. Find the moment of inertia of a hollow rectangular section about its centre of gravity, if the external dimensions are 40 mm deep and 30 mm wide and internal dimensions are 25 mm deep and 15 mm wide. **Ans.  $I_{xx} = 140\ 470\ \text{mm}^4$ ;  $I_{yy} = 82\ 970\ \text{mm}^4$**
12. Calculate the moment of inertia of a hollow circular section of external and internal diameters 100 mm and 80 mm respectively about an axis passing through its centroid.  
**Ans.  $2.898 \times 10^6\ \text{mm}^4$**
13. Find the moment of inertia of a triangular section having 50 mm base and 60 mm height about an axis through its centre of gravity and base. **Ans.  $300 \times 10^3\ \text{mm}^4$ ;  $900 \times 10^3\ \text{mm}^4$**
14. Find the moment of inertia of a semicircular section of 30 mm radius about its centre of gravity and parallel to X-X and Y-Y axes. **Ans.  $89100\ \text{mm}^4$ ;  $381\ 330\ \text{mm}^4$**
15. Compute the moment of inertia of the area about axis K-K. **Ans.  $580.48 \times 10^6\ \text{mm}^4$**

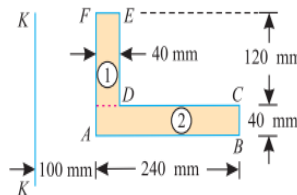

16. Define the terms 'centre of gravity'.
17. Distinguish between centre of gravity and centroid.
18. How many centres of gravity a body has?
19. Describe the various methods of finding out the centre of gravity of a body.
20. How would you find out the centre of gravity of a section, with a cut out hole?
21. A solid body formed by joining the base of a right circular cone of height  $H$  to the equal base of a right circular cylinder of height  $h$ . Calculate the distance of the centre of mass of the solid from its plane face, when  $H = 120$  mm and  $h = 30$  mm. **Ans. 40.7 mm**
22. Find the centre of gravity of a  $T$ -section with flange  $150$  mm  $\times$   $10$  mm and web also  $150$  mm  $\times$   $10$  mm. **Ans. 115 mm for bottom of the web**
23. Find the centre of gravity of an  $T$ -section with top flange  $100$  mm  $\times$   $20$  mm, web  $200$  mm  $\times$   $30$  mm and bottom flange  $300$  mm  $\times$   $40$  mm. **Ans. 79 mm from bottom of lower flange**
24. Find the centre of gravity of an inverted  $T$ -section with flange  $60$  mm  $\times$   $10$  mm and web  $50$  mm  $\times$   $10$  mm. **Ans. 18.6 mm from bottom of the flange**
25. Find the position of the centre of gravity of an unequal angle section  $10$  cm  $\times$   $16$  cm  $\times$   $2$  cm. **Ans. 5.67 cm and 2.67 cm**
26. A body consists of a right circular solid cone of height  $40$  mm and radius  $30$  mm placed on a solid hemisphere of radius  $30$  mm of the same material. Find the position of centre of gravity of the body. **Ans. 27.3 mm**
27. A body consisting of a cone and hemisphere of radius ( $r$ ) on the same base rests on a table, the hemisphere being in contact with the table. Find the greatest height of the cone, so that the combined solid may be in stable equilibrium.
28. A semicircular area is removed from a trapezium as shown in Fig. (dimensions in mm). Determine the centroid of the remaining area (shown hatched). **Ans. 41.1 mm, 26.5 mm**

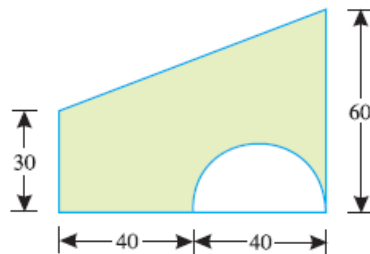

29. A square hole is punched out of circular lamina, the diagonal of the square being the radius of the circle as shown in Fig. Find the centre of gravity of the remainder, if  $r$  is the radius of the circle.

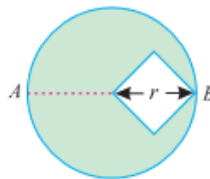



## CHAPTER 5.SIMPLE MACHINES

### LEARNING OUTCOMES:

On completion of the subject, the student will be able to:

- Distinguish between simple and compound machines
- Define common terms related to simple lifting machines.
- Differentiate between reversible and self-locking machines.
- Infer the law of machines.
- Establish the relation between mechanical advantage and load, and between efficiency and load.
- Explain the use and working of simple axle & wheel, single purchase crabwinch& double purchase crab winch, Worm & Worm Wheel, Screw Jack.
- Explain the use and working of different hoisting machine

### 5.1 INTRODUCTION:

Man invented various types of machines for his easy work. Sometimes, one person cannot do heavy work, but with the help of machine, the same work can be easily done.

To change the tyre of a car, number of person will be required. But with the help of a “Jack”, the same work can be done by a single man. Therefore, jack acts as a machine by which the load of a car can be lifted by applying very small force as compared to the load of car.

### SIMPLE MACHINE:

A simple machine is a device by which heavy load can be lifted by applying less effort as compared to the load. A simple machine makes a difficult task easy by multiplying or redirecting the force in a single movement.

e.g. Heavy load of car can be lifted with the help of simple screw jack by applying small force.

### COMPOUND MACHINE:

Compound machine is a device which may consists of number of simple machines. A compound machine may also be defined as a machine which has multiple mechanisms for the same purpose.

e.g. In a crane, one mechanism (gears) are used to drive the rope drum and other mechanism (pulleys) are used to lift the load. Thus, a crane consists of two simple machines or mechanisms i.e. gears and pulleys. Hence, it is a compound machine.

### SIMPLE GEAR DRIVE:

Gears are used to transmit power from one shaft to another shaft. Gear use no intermediate link or connector and transmit the motion by direct contact. In the following figure 5.1 two gear are engaged and rotational motion can be transferred from one gear to other gear.

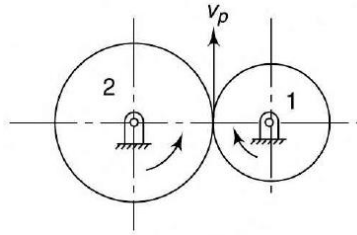

Fig.5.1

$V_p$ = tangential velocity at point of point of contact of two gear

$$V_p = \omega_1 r_1 = \omega_2 r_2$$

$$= \pi d_1 N_1 = \pi d_2 N_2$$

$$\frac{N_1}{N_2} = \frac{d_2}{d_1} \dots \dots \dots (1)$$

N=angular velocity in rpm

$\omega$ =angular velocity in (rad/s)

d=pitch circle diameter.

**SIMPLE GEAR TRAIN:**

In simple gear train each shaft supports one gear. A simple gear drive is that gear drive in which all the gears lie in the same plane. Fig. 5.2 show a simple gear drive in which gear A,  $I_1$  and B lie in the same plane. The gear A is driver gear and gear B is follower gear. Gear  $I_1$  is idle gear. The function of ideal gear is to fill the gap between first gear and last gear and some time it is used to change the direction of rotation of first and last gear

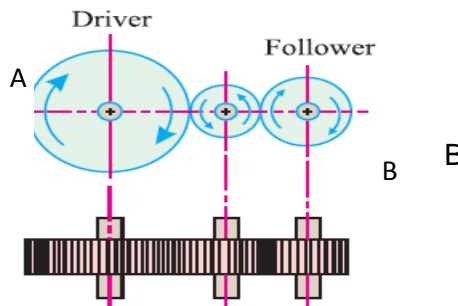

Fig.5.2

## VELOCITY RATIO OF A SIMPLE GEAR TRAIN :

Now consider a simple train of wheels with one intermediate wheel as shown in Fig.5.2

Let  $N_1$  = Speed of the driver

$T_1$  = No. of teeth on the driver

$d_1$  = Diameter of the pitch circle of the driver

$N_2, T_2, d_2$  = Corresponding values for the intermediate wheel, and

$N_3, T_3, d_3$  = Corresponding values for the follower.

$p$  = Pitch of the two wheels.

We know that the pitch of the driver

$$p = \frac{\pi d_1}{T_1} \dots\dots\dots(2)$$

Similarly pitch of the ideal gear

$$p = \frac{\pi d_2}{T_2} \dots\dots\dots(3)$$

Similarly pitch of the follower

$$p = \frac{\pi d_3}{T_3} \dots\dots\dots(4)$$

Since pitch of mating gear are same,

Equating eq<sup>n</sup>(2) and eq<sup>n</sup>(3)

$$\frac{d_1}{d_2} = \frac{T_1}{T_2} \dots\dots\dots (5)$$

Equating eq<sup>n</sup>(3) and eq<sup>n</sup>(4)

$$\frac{d_2}{d_3} = \frac{T_2}{T_3} \dots\dots\dots (6)$$

From eq<sup>n</sup> (1) & (5)

$$\frac{N_1}{N_2} = \frac{T_2}{T_1} \dots\dots\dots (5)$$

Similarly

$$\frac{N_2}{N_3} = \frac{T_3}{T_2} \dots\dots\dots (6)$$

Multiplying eq<sup>n</sup>(5) & (6)

$$\frac{N_1}{N_3} = \frac{T_3}{T_1} \dots\dots\dots (7)$$

**VELOCITY RATIO :**

It is the ratio between the velocities of the driver and the follower

$$\text{Velocity ratio} = \frac{N_1}{N_3} = \frac{T_3}{T_1}$$

**COMPOUND GEAR TRAIN:**

When series of gears are connected in such a way that two or more gears are mounted on same shaft or rotate about an axis with same angular velocity it is known as compound gear train.

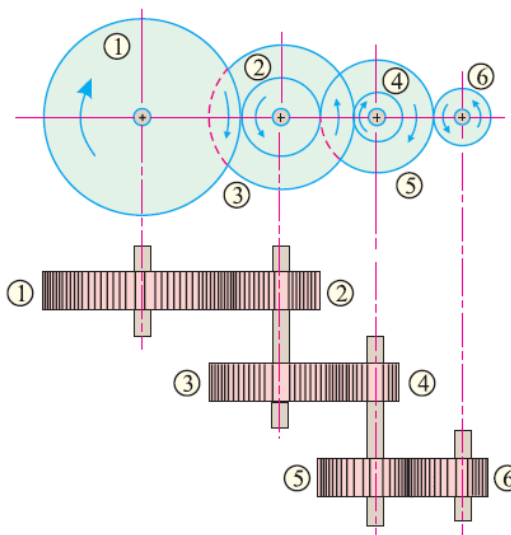

Fig.5.3

$N_1$  = Speed of the driver 1

$T_1$  = No. of teeth on the driver 1,

Similarly

$N_2, N_3, N_4, N_5$  &  $N_6$  = Speed of the respective wheels

$T_2, T_3, T_4, T_5$  &  $T_6$  = No. of teeth on the respective wheels.

Since the gears 1 in mesh with the gear 2, therefore

$$\frac{N_1}{N_2} = \frac{T_2}{T_1} \dots\dots\dots (8)$$

Similarly

$$\frac{N_3}{N_4} = \frac{T_4}{T_3} \dots\dots\dots (9)$$

$$\frac{N_5}{N_6} = \frac{T_6}{T_5} \dots\dots\dots (10)$$

Multiplying eq<sup>n</sup> (8) (9) & (10)

$$\frac{N_1}{N_2} \times \frac{N_3}{N_4} \times \frac{N_5}{N_6} = \frac{T_2}{T_1} \times \frac{T_4}{T_3} \times \frac{T_6}{T_5}$$

Velocity ratio of compound gear train

$$\frac{N_1}{N_6} = \frac{T_2}{T_1} \times \frac{T_4}{T_3} \times \frac{T_6}{T_5} \text{ (as } N_2 = N_3 \text{ and } N_4 = N_5)$$

$$= \frac{\text{Product of the teeth on the followers}}{\text{Product of the teeth on the drivers}}$$

## TERMINOLOGY IN SIMPLE LIFTING MACHINE:

### (M.A, V.R. & Efficiency and relation between them)

**Effort:** It may be defined as, the force which is applied so as to overcome the resistance or to lift the load. It is denoted by 'P'.

**Load:** The weight to be lifted or the resistive force to be overcome with the help of a machine is called as load (W).

**Velocity Ratio (V.R.):** It is defined as the ratio of distance travelled by the effort (Y) to the distance travelled by the load (X)

$$V.R. = \frac{\text{distance travelled by the effort}}{\text{distance travelled by the load}} = \frac{Y}{X}$$

**Mechanical Advantage:** It is defined as the ratio of load to be lifted to the effort applied.

$$M.A. = \frac{\text{Load}}{\text{effort}} = \frac{W}{P}$$

**Input:** The amount of work done by the effort is called as input and is equal to the product of effort and distance travelled by it.

$$\text{Input} = P \times Y$$

Where , P= Effort and Y= distance travelled by the effort

**Output:** The amount of work done by the load is called as output and is equal to the product of load and distance travelled by it.

$$\text{Output} = W \times X$$

Where , W= Load and X= distance travelled by the load

**Efficiency:** The ratio of output to input is called as efficiency of machine and it is denoted by Greek letter eta ( $\eta$ )

$$\eta = \frac{\text{Output}}{\text{Input}} = \frac{W \times X}{P \times Y} = \frac{\text{M.A.}}{\text{V.R}}$$

It is always less than 100% because of friction and losses, therefore M.A. < V.R.

### LAW OF MACHINE:

The equation which gives the relation between load lifted and effort applied in the form of a slope and intercept of a straight line is called as Law of a machine.

$$P = m W + C$$

Where, P = effort applied, W = load lifted, m = slope of the line and C = y – intercept of the straight line.

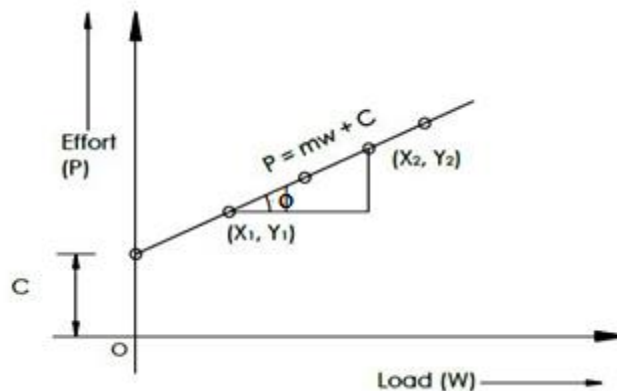

Fig.5.4

$$m = \tan \phi = \frac{Y_2 - Y_1}{X_2 - X_1}$$

It has been observed that, the graph of load v/s effort is a straight line cuts the Y-axis giving the intercept 'C' which indicates the effort lost on friction.

It must be noted that, if the machine is an ideal machine, the straight line of the graph will pass through the origin.

### **MAXIMUM MECHANICAL ADVANTAGE (MAX. M.A.):**

We know that

$$M.A = \frac{W}{P} \quad \text{we know } P = mW + C$$

$$M.A = \frac{W}{mW + C}$$

Dividing numerator and denominator by W

$$M.A = \frac{1}{m + \frac{C}{W}}$$

As  $C \ll W$  the ratio  $\frac{C}{W}$  is very small so by neglecting it the M.A will be maximum

$$M.A_{\max} = \frac{1}{m}$$

### **MAXIMUM EFFICIENCY:**

The ratio of  $M.A_{\max}$  to the V.R. is called as maximum efficiency.

$$\eta_{\max} = \frac{M.A_{\max}}{V.R.} = \frac{1}{m} \times \frac{1}{V.R.}$$

### **REVERSIBLE MACHINE:**

When a machine is capable of doing some work in the reverse direction even on removal of effort, it is called as reversible machine.

**e.g.** simple pulley used to lift load W with effort P

### **CONDITION FOR REVERSIBLE MACHINE:**

Consider a reversible machine, whose condition for the reversibility is required to be found out.

Let W = Load lifted by the machine,  
P = Effort required to lift the load,

y = Distance moved by the effort, and  
x = Distance moved by the load.

We know that input of the machine  
=  $P \times y$  ... (i)  
and output of the machine =  $W \times x$  ... (ii)

We also know that machine friction  
= Input – Output =  $(P \times y) - (W \times x)$  ... (iii)

A little consideration will show that in a reversible machine, the \*output of the machine should be more than the machine friction, when the effort (P) is zero. i.e.

$$W \times x > P \times y - W \times x$$

$$\text{or } 2W \times x > P \times y$$

$$\text{or } W \times x / P \times y > 1/2$$

$$\text{or } (W/P) / (Y/X) > 1/2$$

$$\text{or } M.A/V.R > 1/2$$

$$\dots (M.A = \frac{W}{P} \text{ and } V.R = \frac{Y}{X})$$

$$\eta > \frac{1}{2} = 0.5 = 50\%$$

Hence the condition for a machine, to be reversible is that its efficiency should be *more than* 50%.

## **IRREVERSIBLE MACHINE / NON-REVERSIBLE MACHINE / SELF LOCKING MACHINE:**

When a machine is not capable of doing some work in the reverse direction even on removal of effort, it is called as irreversible machine or non-reversible machine or self-locking machine.

**e.g.** screw jack

**Condition for Irreversible Machine:** The efficiency of the machine should be less than 50%.

**Friction in Machines in terms of Effort and Load:** In any machine, there are number of parts which are in contact with each other in their relative motion. Hence, there is always a frictional resistance and due to which the machine is unable to produce 100 % efficiency.

Let,  $P$  = Actual Effort

$P_i$  = Ideal Effort

$P_f$  = Effort Lost in friction

$$P_f = \text{Actual Effort (P)} - \text{Ideal Effort (P}_i) = P - \frac{W}{V.R}$$



(As  $P_i = \frac{W}{V.R}$  for machine  $\eta=100\%$ )

Let,  $W$  = Actual load lifted

$W_i$  = Ideal load lifted

$W_f$  = Load Lost in friction

$W_f$  = Ideal Load ( $W_i$ ) – Actual load lifted ( $W$ )

$= (P \times V.R) - W$

## 5.2 STUDY OF SIMPLE MACHINES:

### SIMPLE WHEEL AND AXLE:

In simple wheel and axle, effort wheel and axle are rigidly connected to each other and mounted on a shaft. A string is wound round the axle so as to lift the load ( $W$ ) another string is wound round the effort wheel in opposite direction so as to apply the effort ( $P$ ) as shown in the figure 5.5.

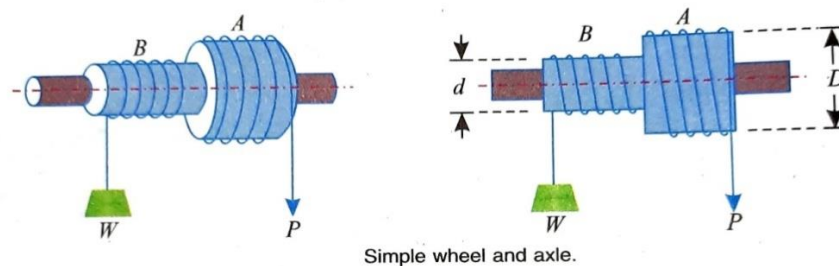

Fig.5.5

Let,  $W$  = Load lifted

$P$  = Effort Applied

$D$  = Diameter of the effort wheel

$d$  = diameter of the load axle

When the effort wheel completes one revolution, the effort moves through a distance equal to the circumference of the effort wheel ( $\pi D$ ) and simultaneously the load moves up through a distance equal to the circumference of the load axle ( $\pi d$ ).

$$V.R. = \frac{\text{Distance travelled by the Effort}}{\text{Distance travelled by the load}} = \frac{\pi D}{\pi d} = \frac{D}{d}$$

## SINGLE PURCHASE CRAB WINCH:

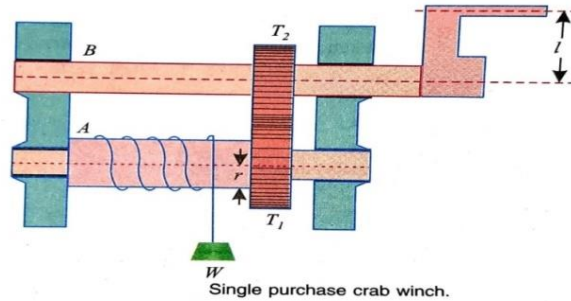

Fig.5.6

In single purchase crab winch, a rope is fixed to the drum and is wound a few turns round it. The free end of the rope carries the load  $W$ . A toothed wheel  $A$  is rigidly mounted on the load drum. Another toothed wheel  $B$ , called pinion, is geared with the toothed wheel  $A$  as shown in Fig. 5.6. The effort is applied at the end of the handle to rotate it.

Let  $T_1$  = No. of teeth on the main gear (or spur wheel)  $A$ ,

$T_2$  = No. of teeth on the pinion  $B$ ,

$l$  = Length of the handle,

$r$  = Radius of the load drum.

$W$  = Load lifted, and

$P$  = Effort applied to lift the load.

We know that,

Distance moved by the effort in one revolution of the handle =  $2\pi l$

No. of revolutions made by the pinion = 1

$\therefore$  No. of revolutions made by the load drum =  $\frac{T_2}{T_1}$

Distance moved by the load =  $2\pi r \times \frac{T_2}{T_1}$

V.R. =  $\frac{\text{Distance travelled by the Effort}}{\text{Distance travelled by the load}} = \frac{l}{r} \times \frac{T_1}{T_2}$

M.A. =  $\frac{W}{P}$

$\eta = \frac{\text{Output}}{\text{Input}} = \frac{\text{M.A.}}{\text{V.R.}}$

## DOUBLE PURCHASE CRAB WINCH:

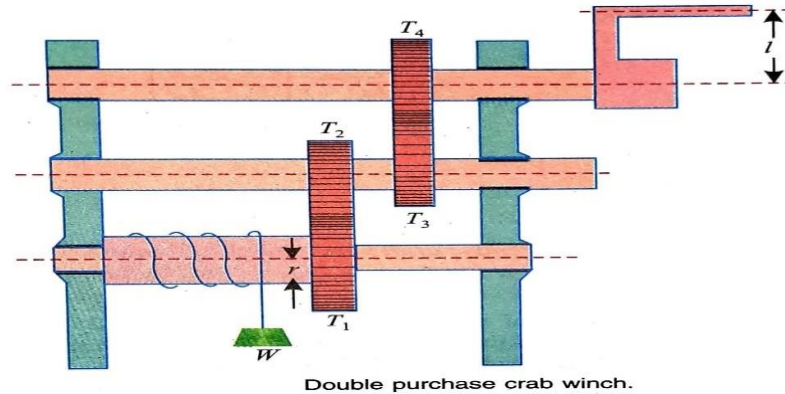

Fig.5.7

A double purchase crab winch is an improved form of a single purchase crab winch, in which the velocity ratio is intensified with the help of one more spur wheel and a pinion. In a double purchase crab winch, there are two spur wheels of teeth  $T_1$  and  $T_2$  and  $T_3$  as well as two pinions of teeth  $T_2$  and  $T_4$ . The arrangement of spur wheels and pinions are such that the spur wheel with  $T_1$  gears with the pinion of teeth  $T_2$ . Similarly, the spur wheel with teeth  $T_3$  gears with the pinion of the teeth  $T_4$ . The effort is applied to a handle as shown in Fig.5.7

Let  $T_1$  and  $T_3$  = No. of teeth of spur wheels,

$T_2$  and  $T_4$  = No. of teeth of the pinions

$l$  = Length of the handle,

$r$  = Radius of the load drum,

$W$  = Load lifted, and

$P$  = Effort applied to lift the load, at the end of the handle. Distance moved by the effort in one revolution of the handle =  $2\pi l$

No. of revolutions made by the pinion D = 1

No. of revolutions made by the spur gear A for 1 revolution of pinion D =  $\frac{T_2}{T_1} \times \frac{T_4}{T_3}$

Distance moved by the load =  $2\pi r \times \frac{T_2}{T_1} \times \frac{T_4}{T_3}$

V.R. =  $\frac{\text{Distance travelled by the Effort}}{\text{Distance travelled by the load}} = \frac{l}{r} \times \frac{T_1}{T_2} \times \frac{T_3}{T_4}$

The V.R. of double purchase winch crab is higher than that of single purchase winch crab.

## WORM AND WORM WHEEL:

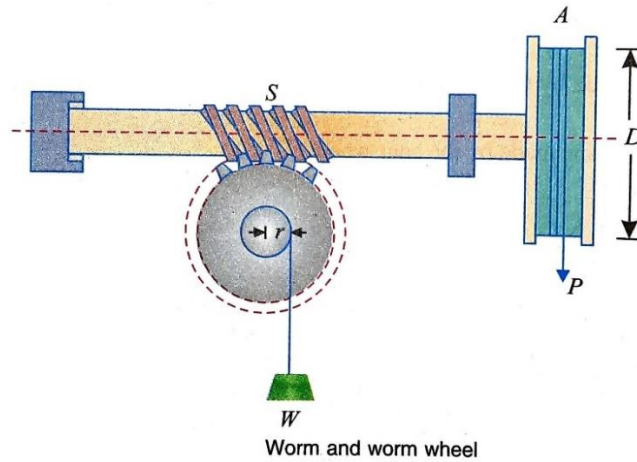

Fig.5.8

It consists of a square threaded screw, S (known as worm) and a toothed wheel (known as worm wheel) geared with each other, as shown in Fig.5.8 . A wheel A is attached to the worm, over which passes a rope as shown in the figure. Sometimes, a handle is also fixed to the worm (instead of the wheel). A load drum is securely mounted on the worm wheel.

Let D = Diameter of the effort wheel,

r = Radius of the load drum

W = Load lifted,

P = Effort applied to lift the load, and

T = No. of teeth on the worm wheel.

For one complete revolution of effort wheel,

Distance moved by the effort P =  $\pi D$

Consider the worm is single threaded.

for one revolution of the wheel A, the screw S pushes the worm wheel through one teeth, then the load drum will move through  $\frac{1}{T}$  revolution

Distance moved by the load =  $\frac{2\pi r}{T}$

$$V.R. = \frac{\text{Distance travelled by the Effort}}{\text{Distance travelled by the load}} = \frac{DT}{2r}$$

$$M.A. = \frac{W}{P}$$

$$\eta = \frac{\text{Output}}{\text{Input}} = \frac{M.A}{V.R}$$

## SCREW JACK:

A screw jack is commonly used for lifting and supporting the heavy load. A very small effort can be applied at the end of the lever or handle or tommy bar for lifting the heavy loads. This effort is very small as compared to the load to be lifted. As jack has a simple mechanism, it is most commonly used in repair work of vehicles.

When the effort is applied to the handle or lever arm to complete one revolution then load is lifted through one pitch of the screw ( $p$ ), therefore the distance moved by the load is equal to the pitch of the screw and the distance moved by the effort is equal to  $2\pi l$

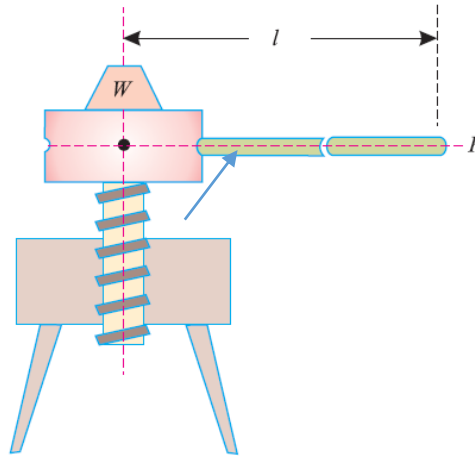

Fig.5.9

Let,  $l$  = length of the handle or lever arm

$p$  = pitch of the thread or screw

$W$  = Load lifted

$P$  = Effort applied to lift the load at the end of the lever.

Distance moved by the effort =  $2\pi l$

Distance moved by the load =  $p$

$$V.R. = \frac{\text{Distance travelled by the Effort}}{\text{Distance travelled by the load}} = \frac{2\pi l}{p}$$

$$M.A. = \frac{W}{P}$$

$$\eta = \frac{\text{Output}}{\text{Input}} = \frac{M.A.}{V.R.}$$

### 5.3 HOISTING MACHINE :

The hoisting is the lifting of the material against gravity

#### Common equipment for hoisting

- Pulley and sheave block
- Chain hoists
- Cranes
- Winches

#### PULLEY AND SHEAVE BLOCK

A pulley is a wheel on an axle or shaft that is designed to support movement and change of direction of a cable or belt along its circumference. Pulleys are used in a variety of ways to lift loads, apply forces, and to transmit power. In nautical contexts, the assembly of wheel, axle, and supporting shell is referred to as a 'block'.

A pulley may also be called a sheave or drum and may have a groove between two flanges around its circumference. The drive element of a pulley system can be a rope, cable, belt, or chain that runs over the pulley inside the groove.

The pulley and sheave blocks suitable for lifting rough surface and heavy loads.

For this purpose, the chains and wire ropes are used.

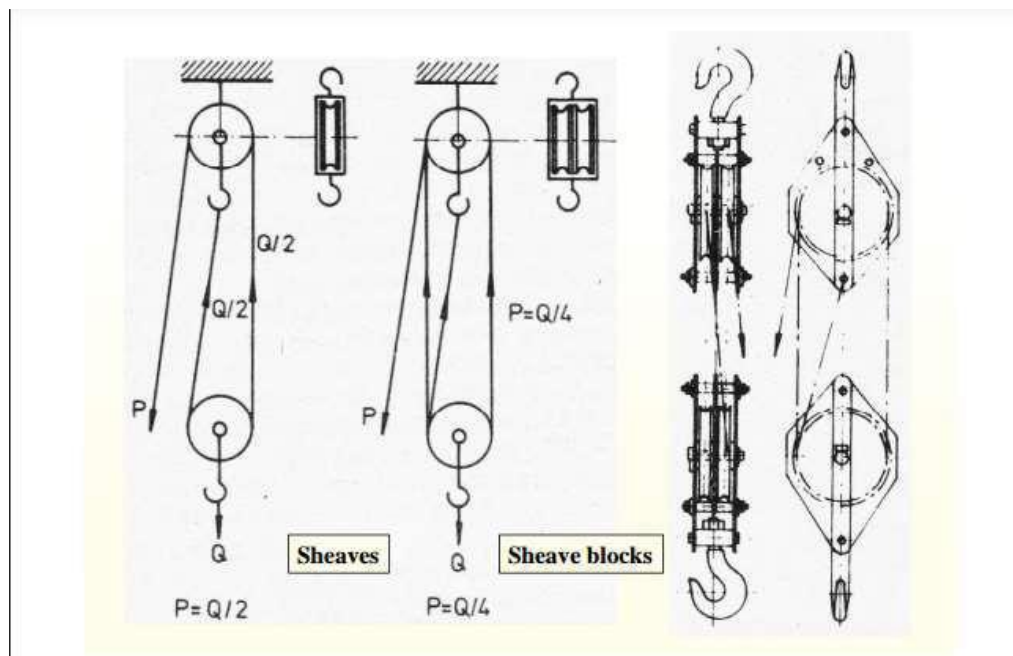

Fig.5.10

## CHAIN HOISTS

- The chain hoists are the popular mechanism for lifting loads up to tones.
- The system consists of two sets of chains, namely the hand and load chain.
- The hand chains are particularly useful for the isolated location, where an electric motor or other types of mechanical equipment are not available.
- The pull applied through the hand chain is transmitted to the load chain with a multiplication factor of over 20.
- The load to be lifted is held by a load hook while another hook (called support hook) at the top, support the mechanism.



Fig.5.11

## CRANES

A crane is a type of machine, generally equipped with a Hoist rope or chain, and sheaves, that can be used both to lift and lower the materials and to move them horizontally. It is mainly used for lifting heavy Things and transporting them to other places.

Types of cranes

- Mobile crane
- truck mounted crane
- tower crane
- overhead crane
- derrick crane

## MOBILE CRANE

A mobile crane is a cable-controlled crane Mounted on crawlers or ribbed-tired carries or A hydraulic-powered crane with a telescopic Boom mounted on truck-type carriers or as self-propelled Models



Fig.5.12

## TRUCK MOUNTED CRANE

- Truck-mounted crane is a self-propelled loading unloading Machine mounted on a truck Body, with a working section consisting of a Rotating cantilevered boom.
- these cranes are supported (outriggers) while Lifting cargo, in order to increase their stability.



Fig.5.13

## TOWER CRANE

- These are the crane of swing job type and are mounted on high steel towers.
- The height of tower maybe 25 to 30 m and these cranes are found to be suitable in the construction of tall buildings in congested areas.
- The ground area required for such cranes is very small.





Fig.5.14

## OVERHEAD CRANE

- An overhead crane, commonly called a bridge Crane, is a type of crane found in industrial Environments. An overhead crane consists of Parallel runways with a travelling bridge Spanning the gap.
- A hoist, the lifting component of a crane, travels Along a bridge.



Fig.5.15

## DERRICK CRANES

- The derrick cranes are of two types, namely
  1. Guy derrick
  2. Stiff leg derrick
- The guy derrick consists of a vertical mast. This mast is supported by the number of guys and can revolve through  $360^{\circ}$
- While revolving, the radius of revolution should be such that the revolving structure is not obstructed by the guy wires.
- This derrick can be constructed up to 200 tonnes capacity.
- In stiff leg type derricks, the guy wires are replaced by trussed structure.
- The power is supplied by a diesel engine or by an electric motor.



Fig.5.16

**Q.5.1 In a certain weight lifting machine, a weight of 1 kN is lifted by an effort of 25 N. While the weight moves up by 100 mm, the point of application of effort moves by 8 m. Find mechanical advantage, velocity ratio and efficiency of the machine.**

Solution:

Given: Weight ( $W$ ) = 1 kN = 1000 N ; Effort ( $P$ ) = 25 N ;

Distance through which the weight is moved ( $Y$ ) = 100 mm = 0.1 m and distance through which effort is moved ( $x$ ) = 8 m.

Mechanical advantage of the machine.

$$M.A = \frac{W}{P} = \frac{1000}{25} = 40$$

Velocity ratio of the machine

$$V.R. = \frac{\text{distance travelled by the effort } X}{\text{distance travelled by the load } Y} = \frac{8}{0.1} = 80$$

Efficiency of the machine

$$\eta = \frac{\text{Output}}{\text{Input}} = \frac{M.A}{V.R} = \frac{40}{80} = 0.5 = 50\%$$

**Q.5.2A certain weight lifting machine of velocity ratio 30 can lift a load of 1500N with the help of 125 N effort. Determine if the machine is reversible.**

Solution:..Given: Velocity ratio ( $V.R.$ ) = 30; Load ( $W$ ) = 1500 N and effort ( $P$ ) = 125 N.

$$\text{We know that } M.A = \frac{W}{P} = \frac{1500}{125} = 12$$

$$\text{and efficiency, } \eta = \frac{\text{Output}}{\text{Input}} = \frac{M.A}{V.R} = \frac{12}{30} = 0.4 = 40\%$$

Since efficiency of the machine is less than 50%, therefore the machine is non-reversible.

**Q.5.3. What load can be lifted by an effort of 120 N, if the velocity ratio is 18 and efficiency of the machine at this load is 60%? Determine the law of the machine, if it is observed that an effort of 200 N is required to lift a load of 2600 N and find the effort required to run the machine at a load of 3.5 kN.**

Solution:

Given: Effort (P) = 120 N ; Velocity ratio (V.R.) = 18 and efficiency ( $\eta$ ) = 60% = 0.6.

Load lifted by the machine,

Let W = Load lifted by the machine

We know that  $M.A = \frac{W}{P} = \frac{W}{120}$

and efficiency,  $0.6 = \frac{M.A}{V.R} = \frac{W}{120 \times 18} = \frac{W}{2160}$

$W = 0.6 \times 2160 = 1296 \text{ N}$

Law of the machine

In the second case, P = 200 N and W = 2600 N

Substituting the two values of P and W in the law of the machine, i.e.,  $P = mW + C$ ,

$120 = m \times 1296 + C \dots\dots\dots(i)$

$200 = m \times 2600 + C \dots\dots\dots(ii)$

Subtracting equation (i) from (ii),

$80 = 1304 m$

$m = 0.06$

and now substituting the value of m in equation (ii)

$200 = (0.06 \times 2600) + C = 156 + C$

$C = 200 - 156 = 44$

Now substituting the value of m = 0.06 and C = 44 in the law of the machine,

$P = 0.06W + 44$

Effort required to run the machine at a load of 3.5 kN.

Substituting the value of W = 3.5 kN or 3500 N in the law of machine,

$P = (0.06 \times 3500) + 44 = 254 \text{ N}$

**Q.5.4. A simple wheel and axle has wheel and axle of diameters of 300 mm and 30 mm respectively. What is the efficiency of the machine, if it can lift a load of 900 N by an effort of 100 N.**

Solution: Given: Diameter of wheel (D) = 300 mm; Diameter of axle (d) = 30 mm; Load lifted by the machine (W) = 900 N and effort applied to lift the load (P) = 100 N

We know that velocity ratio of the simple wheel and axle,

$V.R. = \frac{D}{d} = \frac{300}{30} = 10$

and mechanical advantage  $M.A = \frac{W}{P} = \frac{900}{100} = 9$

$$\text{Efficiency } \eta = \frac{\text{Output}}{\text{Input}} = \frac{\text{M.A}}{\text{V.R}} = \frac{90}{10} = 0.9 = 90\%$$

**Q.5.5 In a single purchase crab winch, the number of teeth on pinion is 25 and that on the spur wheel 100. Radii of the drum and handle are 50 mm and 300 mm respectively. Find the efficiency of the machine and the effect of friction, if an effort of 20 N can lift a load of 300 N.**

Solution: Given: No. of teeth on pinion ( $T_2$ ) = 25;

No. of teeth on the spur wheel ( $T_1$ ) = 100;

Radius of drum ( $r$ ) = 50 mm;

Radius of the handle or length of the handle ( $l$ ) = 300 mm;

Effort ( $P$ ) = 20 N and load lifted ( $W$ ) = 300 N.

We know that velocity ratio,

$$\text{V.R.} = \frac{\text{Distance travelled by the Effort}}{\text{Distance travelled by the load}} = \frac{l}{r} \times \frac{T_1}{T_2} = \frac{300}{50} \times \frac{100}{25} = 24$$

$$\text{M.A} = \frac{W}{P} = \frac{300}{20} = 15$$

$$\eta = \frac{\text{M.A}}{\text{V.R}} = \frac{15}{24} = 0.625$$

Effect of friction

$$P_f = \text{Effort Lost in friction} = P \times \frac{W}{\text{V.R}} = 20 \times \frac{300}{24} = 7.5 \text{ N}$$

$$W_f = \text{Load Lost in friction} = (P \times \text{V.R.}) - W = (20 \times 24) - 300 = 180 \text{ N}$$

It means that if the machine would have been ideal (i.e. without friction) then it could lift an extra load of 180 N with the same effort of 20 N. Or it could have required 7.5 N less force to lift the same load of 300 N.

**Q.5.6 In a double purchase crab winch, teeth of pinions are 20 and 25 and that of spur wheels are 50 and 60. Length of the handle is 0.5 metre and radius of the load drum is 0.25 metre. If efficiency of the machine is 60%, find the effort required to lift a load of 720 N.**

Solution: Given: No. of teeth of pinion ( $T_2$ ) = 20 and ( $T_4$ ) = 25;

No. of teeth of spur wheel ( $T_1$ ) = 50 and ( $T_3$ ) = 60;

Length of the handle ( $l$ ) = 0.5 m; Radius of the load drum ( $r$ ) = 0.25 m;

Efficiency ( $\eta$ ) = 60% = 0.6 and load to be lifted ( $W$ ) = 720 N.

Let  $P$  = Effort required in newton to lift the load.

We know that velocity ratio

$$\text{V.R.} = \frac{\text{Distance travelled by the Effort}}{\text{Distance travelled by the load}} = \frac{l}{r} \times \frac{T_1}{T_2} \times \frac{T_3}{T_4} = \frac{0.5}{0.25} \times \frac{50}{20} \times \frac{60}{25} = 12$$

$$M.A = \frac{W}{P} = \frac{720}{P}$$

$$\eta = \frac{M.A}{V.R} = \frac{720/P}{12} = \frac{60}{P} = 0.6$$

$$P = 100N$$

**Q.5.7 A screw jack has a thread of 10 mm pitch. What effort applied at the end of a handle 400 mm long will be required to lift a load of 2 kN, if the efficiency at this load is 45%.**

Solution : Given: Pitch of thread ( $p$ ) = 10 mm;

Length of the handle ( $l$ ) = 400 mm;

Load lifted ( $W$ ) = 2 kN = 2000 N and efficiency ( $\eta$ ) = 45% = 0.45.

Let  $P$  = Effort required to lift the load.

We know that velocity ratio

$$V.R. = \frac{\text{Distance travelled by the Effort}}{\text{Distance travelled by the load}} = \frac{2\pi l}{p} = \frac{2\pi \times 400}{10} = 251.3$$

$$M.A = \frac{W}{P} = \frac{2000}{P}$$

We also know that efficiency,

$$0.45 = \frac{M.A}{V.R} = \frac{2000/P}{251.3} = \frac{7.96}{P}$$

$$P = 17.7N$$

**Q.5.8 A worm and worm wheel with 40 teeth on the worm wheel has effort wheel of 300 mm diameter and load drum of 100 mm diameter. Find the efficiency of the machine, if it can lift a load of 1800 N with an effort of 24 N.**

Solution : Given: No. of teeth on the worm wheel ( $T$ ) = 40

Diameter of effort wheel ( $D$ ) = 300 mm

Diameter of load drum = 100 mm or radius ( $r$ ) = 50 mm

Load lifted ( $W$ ) 1800 N and effort ( $P$ ) = 24 N.

We know that velocity ratio of worm and worm wheel

$$V.R. = \frac{DT}{2r} = \frac{300 \times 40}{250} = 120$$

$$M.A = \frac{W}{P} = \frac{1800}{24} = 75$$

$$\eta = \frac{M.A}{V.R} = \frac{75}{120} = 0.625 = 62.5\%$$

## EXERCISES

1. What is a machine? Explain the difference between a simple machine and a compound machine.
2. Define mechanical advantage of a machine.
3. What is an ideal machine?
4. Define velocity ratio of a machine.
5. Derive the relation between mechanical advantage, velocity ratio and efficiency of a machine.
6. Explain how the efficiency of a simple machine is determined ?
7. What do you understand by the term 'Reversibility' of a machine? Explain the difference between a reversible machine and a self-locking machine.
8. What is law of a machine? Derive an equation for the same.
9. Obtain an equation for the maximum mechanical advantage and maximum efficiency of a machine.
10. What is meant by 'friction in a machine'? In how many ways it can be expressed in terms of velocity ratio?
11. In a worm and worm wheel, the number of teeth in the worm wheel is 25. The effort handle is 300 mm long and the load drum is 150 mm diameter. Find the efficiency of the machine, if an effort of 30 N can lift a load of 345 N and the worm is double threaded. **Ans. 23%**
12. A single purchase crab has 300 mm long handle, 120 mm diameter drum and diameter of the lifting rope is 10 mm. Number of teeth on the pinion are 25 and that on the wheel 130. Calculate the velocity ratio of the crab. If an effort of 20 N lifts a load of 300 N, what is the mechanical advantage and efficiency of the crab? **Ans. 24; 15; 62.5%**
13. In a single purchase crab winch, length of the handle is 160 mm and the gear ratio is 5. Find the velocity ratio and efficiency of the machine, if a load of 1 kN is lifted by an effort of 50 N. Take diameter of the drum as 60 mm. **Ans. 26.67 ; 75%**
14. In a double purchase crab winch the pinions have 15 and 20 teeth respectively, while the spur wheels have 45 and 40 teeth. The effort handle is 400 mm long and the effective diameter of the drum is 200 mm. If the efficiency of the winch is 50%, find the effort required to lift a load of 1500 N. **Ans. 125 N**
15. A simple screw jack has a thread of pitch 12 mm. Find the load that can be lifted by an effort of 20 N applied at the end of handle 500 mm long. Take efficiency of the machine as 50%. **Ans. 2.094 kN**
16. In a simple screw jack, the pitch of the screw is 10 mm and length of the handle is 450 mm. Find the velocity ratio. If an effort of 25 N applied at the end of the handle can lift a load of 3 kN, find the efficiency of the jack. Also calculate the amount of effort wasted in friction and the frictional load. **Ans. 282.7 ; 42.4% ; 14.4 N ; 4.068 kN**
17. In a lifting machine, whose velocity ratio is 50, an effort of 100 N is required to lift a load of 4 kN. Is the machine reversible? If so, what effort should be applied, so that the machine is at the point of reversing? **Ans. 160 N**

## CHAPTER 6: DYNAMICS

### LEARNING OUTCOMES

On completion of the subject, the student will be able to:

- Understand Newton's laws of motion and its significance
- Understand and apply the equations of motion to solve problems
- Explain D' Alembert's principle and apply to solve problems
- Understand the concept of work, energy and power
- Define momentum and impulse and derive their relation
- Explain the law of conservation of linear momentum and law of conservation of energy
- Understand and apply Newton's law of collision and coefficient of restitution for elastic bodies

### 6.1 KINEMATICS AND KINETICS

**KINEMATICS:** It is that branch of Dynamics, which deals with motion of bodies without considering the forces causing motion.

**KINETICS:** It is that branch of Dynamics, which deals with motion of bodies and the forces causing the motion. It predicts the type of motion by a given force system.

#### PRINCIPLES OF DYNAMICS:

#### NEWTON'S LAWS OF MOTION

- (a) **First Law of motion:** It states, "Everybody continues in its state of rest or of uniform motion in a straight line, unless compelled by some external force to change that state".

This law can also termed as law of inertia.

- (b) **Second law of motion:** It states, "The rate of change of momentum is directly proportional to the impressed force and takes place in the same direction in which the impressed force acts".

It relates to the rate of change of momentum and the external force.

Let,  $m$  = mass of the body

$u$  = initial velocity of the body

$v$  = final velocity of the body

$a$  = constant acceleration

$t$  = time in seconds in which the velocity changes from  $u$  to  $v$

$F$  = force that changes the velocity from  $u$  to  $v$  in  $t$  seconds

For the body moving in straight line,

Initial momentum =  $mu$

Final momentum =  $mv$

$$\text{Rate of change of momentum} = \frac{mv - mu}{t} = \frac{m(v - u)}{t} = ma$$

$$\text{Where } \frac{v - u}{t} = a$$

According to Newton's Second law of motion;

Rate of change of momentum  $\propto$  impressed force

$$\Rightarrow F \propto ma$$

$$\Rightarrow F = k \times ma$$

Where  $k$  = a constant of proportionality

If a unit force is chosen to act on a unit mass of 1kg to produce unit acceleration of  $1\text{m/s}^2$

then,  $F=ma= \text{Mass} \times \text{Acceleration}$

The SI unit of force is Newton, briefly written as N

(c) **Third law of motion:** It states, "To every action, there is always an equal and opposite reaction".

If a body exerts a force  $P$  on another body, the second body will exert the same force  $P$  on the first body in the opposite direction. The force exerted by first body is called action where as the force exerted by the second body is called reaction.

### MOTION OF PARTICLE ACTED UPON BY A CONSTANT FORCE

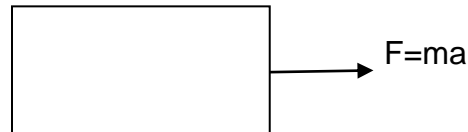

Fig 6.1

The motion of a particle acted upon by a constant force is governed by Newton's second law of motion.

If a constant force,  $F = ma$  is applied on a particle of mass 'm', then the particle will move with a uniform acceleration 'a'.

### EQUATIONS OF MOTION

Let,  $u$  = initial velocity of the body

$v$  = final velocity of the body

$s$  = distance travelled by the body in motion

$a$  = acceleration of the body

$t$  = time taken by the body

$\therefore$  The equations of motion are:

$$v = u + at$$

$$s = ut + \frac{1}{2}at^2$$

$$v^2 - u^2 = 2as$$

### D' ALEMBERT'S PRINCIPLE

It states, "If a rigid body is acted upon by a system of forces, this system may be reduced to a single resultant force whose magnitude, direction and the line of action may be found out by the methods of graphic statics."

Let,  $P$  = resultant of number of forces acting on a body of mass  $m$

This resultant ( $P$ ) will move the body with an acceleration( $a$ ) in its own direction.

We have,  $P=ma$  .....(1)



The body will be at rest if a force equal to  $ma$  is applied in reverse direction. Hence, for dynamic equilibrium of the body, the sum of the resultant force and the reversed force will be equal to zero.

$$P - ma = 0 \dots\dots\dots(2)$$

The force  $(-ma)$  is known as inertia force or reversed effective force. Equation 1 is an equation of dynamics where as equation 2 is an equation of statics. Equation 2 is known as the equation of dynamic equilibrium under the action of  $P$ . This principle is known as D' Alembert's principle.

**RECOIL OF GUN**

According to Newton's third law of motion, when a bullet is fired from a gun, the opposite reaction of the bullet is known as the recoil of gun.

Let,  $M$  = mass of the gun

$V$  = Velocity of the gun with which it recoils

$m$  = mass of the bullet

$v$  = velocity of the bullet after firing

Now, momentum of the bullet after firing =  $mv$  .. .. .(1)

Momentum of the gun =  $MV$  .. .. .(2)

Equating equations (1) & (2) we get,

$$mv = MV$$

This relation is known as law of Conservation of Momentum.

**6.2 WORK**

When force acts on a body and the body undergoes some displacement, then work is said to be done. The amount of work done is equal to the product of force and displacement in the direction of force.

Let,  $P$  = force acting on the body

and  $s$  = distance through which the body moves

Then work done,  $W = P \times s$

Sometimes the force and displacement are not collinear.

In such a case, work done is expressed as the product of the component of the force in the direction of motion and the displacement.

Hence, work done  $W = P \cos\theta \times s$

If  $\theta = 90^\circ$ ,  $\cos \theta = 0$  and there will be no work done i.e. if force and displacement are at right angles to each other, work done will be zero.

Similarly, work done against the force is taken as negative.

When the point of application of the force moves in the direction of motion of the body, work is said to be done by the force.

Work done by the force is taken as +ve.

As work is the product of force and displacement, the units of work depend upon the units of force and displacement. Work is expressed in N-m or KN-m.

One Newton-meter is the work done by a force of 1N in moving the body through 1m. It is called Joule.  $1J = 1 N\cdot m$  . Similarly, 1 Kilo Newton-meter is the work done by a force of 1 KN in moving a body through 1m. It is also called kilojoules.  $1KJ = 1 KN\cdot m$

## POWER

Power is defined as the rate of doing work.

In SI units, the unit of power is watt (briefly written as W) which is equal to 1 N-m/s or 1 J/s. It is also expressed in Kilowatt (KW), which is equal to  $10^3$  W and Megawatt (MW) which is equal to  $10^6$  W. In case of engines, the following two terms are commonly used for power.

**INDICATED POWER:** It is the actual power generated in the engine cylinder

**BRAKE POWER:** It is the amount of power available at the engine shaft

Efficiency of engine is expressed as the ratio of brake power to the indicated power.

It is also called Mechanical efficiency of an engine.

Mathematically, efficiency,  $\eta = \frac{BP}{IP}$

## ENERGY

Energy may be defined as the capacity for doing work.

Since energy of a machine is measured by the work it can do, therefore unit of energy is same as that of work.

In S.I system, energy is expressed in Joules or Kilojoules.

There are two types of mechanical energy.

**1.POTENTIAL ENERGY:** It is the energy possessed by a body by virtue of its position.

A body at some height above the ground level possesses potential energy. If a body of mass (m) is raised to a height (h) above the ground level, the work done in raising the body is

= Weight of the body  $\times$  distance through which it moved

= (mg)  $\times$  h = mgh

This work (equal to mgh) is stored in the body as potential energy.

The body, while coming down to its original level, can do work equal to mgh.

Potential energy is zero when the body is on the earth.

**2.KINETIC ENERGY:** It is the energy possessed by a body by virtue of its motion. We can measure kinetic energy of a body by finding the work done by the body against external force to stop it.

Let, m= Mass of the body

u= Velocity of the body at any instant

P= External force applied

a=Constant Retardation of the body

s= distance travelled by the body before coming to rest

As the body comes to rest its final velocity v = 0

and work done, W = Force  $\times$  Distance = P  $\times$  s ..... (1)

Now substituting value of (P = m.a) in equation (1),

W = ma  $\times$  s = mas .....(2)

But,  $v^2 - u^2 = -2as$  (for retardation)

0 -  $u^2 = -2as$

$u^2 = 2as$

$as = \frac{1}{2}u^2$

Now substituting value of (a.s) in equation (2) and replacing work done with kinetic energy

Kinetic energy  $KE = \frac{1}{2}mu^2$

If initial velocity is taken as v instead of u then  $KE = \frac{1}{2}mv^2$

**6.3 MOMENTUM AND IMPULSE**

**MOMENTUM:** It is the product of mass and velocity of a body. It represents the energy of motion stored in a moving body.

If, m = mass of a moving body in kg

v = velocity of the body in m/sec,

∴ Momentum of the body = mv kg-m/sec

**IMPULSE:** It is defined as the product of force and time during which the force acts on the body.

According to the second law of motion,

$F = ma$

$\Rightarrow F = m \cdot \frac{dv}{dt} = \frac{d}{dt}(mv) = \frac{mv - mu}{t} \dots \dots \dots (1)$

where, v = Final velocity

u = Initial velocity

We have mu = momentum of the body at the beginning of motion

mv = momentum of the body after time t

From equation (1), we see that change in linear momentum per unit time is directly proportional to the external force or applied force and takes place in the direction of force.

∴  $F \times t = mv - mu \dots \dots \dots (2)$

$= m(v - u)$

Hence, Impulse, I =  $F \times t = mv - mu$

i.e. impulse is equal to change in momentum

Equation (2) is known as impulse – momentum relation.

**LAW OF CONSERVATION OF LINEAR MOMENTUM**

It states that “the total momentum of two bodies remains constant after their collision or any other mutual action.

And no external forces act on the bodies, the algebraic sum of their momentum along any direction is constant.

Momentum along a straight line is called linear momentum

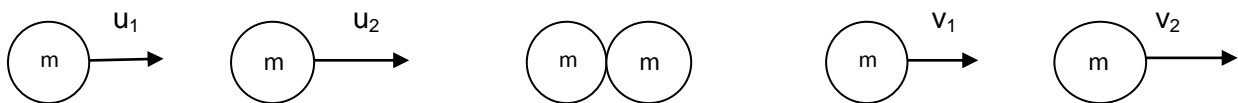

Fig 6.2

If a body of mass  $m_1$  moving with velocity  $u_1$  collides with another body of mass  $m_2$  moving with velocity  $u_2$ .

Let  $v_1$  and  $v_2$  be the velocities of the bodies after collision.

We have: total momentum before collision =  $m_1u_1 + m_2u_2$

Total momentum after collision =  $m_1v_1 + m_2v_2$

Now, according to the law of conservation of linear momentum,

∴ Momentum before collision = momentum after collision

$$\Rightarrow m_1u_1 + m_2u_2 = m_1v_1 + m_2v_2$$

### LAW OF CONSERVATION OF ENERGY

It states that “ The energy can neither be created nor destroyed, though it can be transformed from one form into any of the forms, in which the energy can exist.”

Suppose a body of mass ‘m’ is at a height ‘h’ dropped on the ground from A.

Consider the ground level as the datum or reference level and other positions of B and C of the same body at various times of the fall

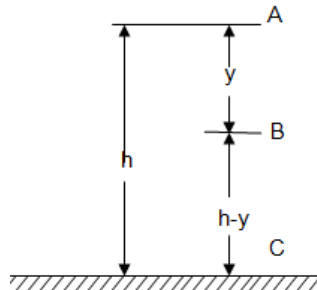

Fig 6.3

Total energy of the body at these points (A,B,C)

Energy at A

At A, the body has no velocity, therefore kinetic energy at A=0

And potential energy at A =mgh

$$\therefore \text{Total energy at A} = mgh \quad \dots\dots\dots(1)$$

Energy at B

At B, the body has fallen through a distance (y). Therefore velocity of the body at B

$$= \sqrt{2gy}$$

$$\therefore \text{Kinetic energy at B} = \frac{mv^2}{2} = \frac{m(\sqrt{2gy})^2}{2} = mgy$$

and potential energy at B = mg (h – y)

$$\therefore \text{Total energy at B} = mgy + mg (h - y) = mgh \quad \dots\dots\dots(2)$$

Energy at C

At C, the body has fallen through a distance (h). Therefore velocity of the body at C

$$= \sqrt{2gh}$$

$$\therefore \text{Kinetic energy at C} = \frac{mv^2}{2} = \frac{m(\sqrt{2gh})^2}{2} = mgh$$

and potential energy at C = 0

$$\therefore \text{Total energy at C} = mgh \quad \dots\dots\dots(3)$$

It shows that in all positions, the sum of kinetic and potential energies of a body remains constant under the action of gravity.

## **COLLISION OF ELASTIC BODIES**

Collision means the interaction or the contact between two bodies for a short period of time. The bodies produce impulsive forces on each other during collision.

The act of collision between two bodies that takes place in a short period of time and during which the bodies exert very large forces on each other, is known as impact.

The bodies come to rest for a moment immediately after collision. During the phenomenon of collision, the bodies tend to compress each other.

The bodies tend to regain their actual shape and size after impact, due to elasticity. The process of getting back the original shape is called restitution.

The time of compression is the time taken by the two bodies in compression, immediately after collision and the time of restitution is the time of regaining the original shape after collision. The period of collision is the sum of the time of compression and restitution.

## **NEWTON'S LAW OF COLLISION OF ELASTIC BODIES AND COEFFICIENT OF RESTITUTION**

Newton's law of collision of elastic bodies states that "when two moving bodies collide with each other, their velocity of separation bears a constant ratio to their velocity of approach".

Let us consider two bodies A and B of masses  $m_1$  and  $m_2$  respectively move along the same line and produce direct impact.

Let  $u_1$  = initial velocity of body A

$u_2$  = initial velocity of body B

$v_1$  = final velocity of body A after collision

$v_2$  = final velocity of body B after collision

The impact will take place when  $u_1 > u_2$

Hence the velocity of approach =  $u_1 - u_2$

After impact, the separation of the two bodies will take place if  $v_2 > v_1$

Hence the velocity of separation =  $v_2 - v_1$

According to Newton's law of Collision of Elastic bodies,

$$(v_2 - v_1) \propto (u_1 - u_2)$$

$$\Rightarrow (v_2 - v_1) = e (u_1 - u_2)$$

where,  $e$  = a constant of proportionality known as coefficient of restitution.

The value of 'e' lies between 0 and 1. If  $e = 0$ , it indicates that the two bodies are inelastic. If  $e = 1$ , it indicates that the two bodies are perfectly elastic.

## **DIRECT COLLISION OF TWO BODIES**

Consider two bodies A and B having a direct impact

Let,  $m_1$  = Mass of the body A

$u_1$  = Initial velocity of body A

$v_1$  = Final velocity of body A

$m_2, u_2, v_2$  = Corresponding values for the body B

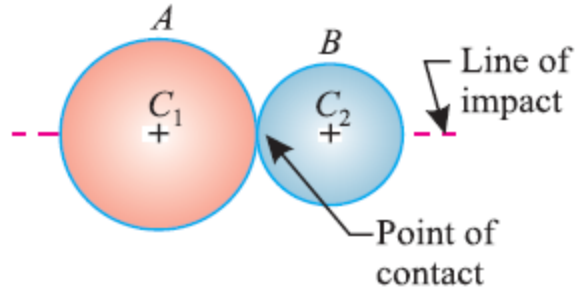

Fig 6.4

According to law of conservation of linear momentum, we have,

$$m_1u_1 + m_2u_2 = m_1v_1 + m_2v_2$$

### DIRECT IMPACT OF A BODY WITH A FIXED PLANE

If one body is at rest initially, then such a collision is called direct impact.

Consider direct impact of a body with a fixed plane.

Let,  $u$  = initial velocity of the body

$v$  = final velocity of the body

$e$  = coefficient of restitution

Here, the velocity of approach is ' $u$ ' and velocity of separation is ' $v$ '.

According to Newton's law of elastic bodies, we have,

velocity of separation  $\propto$  velocity of approach

$$\Rightarrow v \propto u$$

$$\Rightarrow v = eu$$

### EXAMPLES

**EXAMPLE 6.1:** A body of mass 10 kg is moving with a velocity of 2 m/sec. If a force of 20N is applied on the body, determine its velocity after 2 seconds.

**Solution:** Given, Mass of the body  $m = 10$  kg

Velocity of the body  $u = 2$  m/sec

Force  $F = 20$  N

Acceleration of the body,  $a = \frac{F}{m} = \frac{20}{10} = 2$  m/sec<sup>2</sup>

Velocity of the body after 2 seconds,

$$\begin{aligned} v &= u + at \\ &= 2 + (2 \times 2) \\ &= 6 \text{ m/sec} \end{aligned}$$

**EXAMPLE 6.2:** A vehicle of mass 500kg, is moving with a velocity of 25 m/sec. A force of 200 N acts on it for 2 minutes. Find the velocity of the vehicle :

(a) When the force acts in the direction of the motion, and

(b) When the force acts in the opposite direction of the motion.

**Solution:** Given, Mass of the body  $m = 500\text{kg}$

Initial velocity of the body,  $u = 25 \text{ m/sec}$

Force  $F = 200 \text{ N}$

Time  $(t) = 2 \text{ min} = 120 \text{ seconds}$

$$(a) \text{ Acceleration of the vehicle, } a = \frac{F}{m} = \frac{200}{500} = 0.4\text{m/sec}^2$$

Velocity of the vehicle after 120 seconds:

$$\begin{aligned}v_1 &= u + at \\ &= 25 + (0.4 \times 120) \\ &= 73 \text{ m/sec}\end{aligned}$$

(b) Here, acceleration of the vehicle,  $a = -0.4 \text{ m/sec}^2$

Velocity of the vehicle after 120 sec,

$$v_2 = u + at$$

$$= 25 + (-0.4 \times 120)$$

$$= -23 \text{ m/sec (Minus sign indicates vehicle is moving in reverse direction)}$$

**EXAMPLE 6.3:** A man of mass 100 kg dives vertically downwards into a swimming pool from a tower of height 30 m. He was found to go down in water by 3 m and then started rising. Find the average resistance of the water. Neglect the resistance of air.

**Solution.** Given : Mass of the man ( $m$ ) = 100 kg and height of the tower ( $s$ ) = 30 m

Consider the motion of the man from the top of the tower to the water surface.

Here, initial velocity ( $u$ ) = 0 (as the man dives) and distance covered ( $s$ ) = 30 m

Let  $v$  = Final velocity of the man when he reaches the water surface.

$$\text{Now } v^2 = u^2 + 2gs = (0)^2 + 2 \times 9.81 \times 30$$

$$\therefore v = \sqrt{588.6} = 24.26\text{m/s}$$

Now consider motion of the man from the water surface up to the point in water from where he started rising.

In this case, initial velocity ( $u$ ) = 24.26 m/s ; final velocity ( $v$ ) = 0 (as the man comes to rest) and distance covered ( $s$ ) = 3 m

Let  $a$  = Retardation due to water resistance.

$$\text{Now } v^2 = u^2 + 2as$$

$$0 = (24.26)^2 - 2a \times 3 = 588.6 - 6a \dots (\text{Minus sign due to retardation})$$

$$\therefore a = \frac{588.6}{6} = 98.1\text{m/s}^2$$

and average resistance of the water,

$$F = ma = 100 \times 98.1 = 9810 \text{ N}$$

**EXAMPLE 6.4:** Two bodies A and B of mass 80 kg and 20 kg are connected by a thread and move along a horizontal plane under the action of force 400 N applied to the first body of mass 80kg. The coefficient of friction between the sliding surfaces of the bodies and the plane is 0.3. Determine the acceleration of the two bodies and the tension in the thread using D' Alembert's principle.

**Solution:** Given, Mass of body A ( $m_1$ ) = 80 kg

Mass of body B( $m_2$ ) = 20 kg  
 Force applied on first body( $P$ ) = 400 N  
 Coefficient of friction ( $\mu$ ) = 0.3  
 Let us consider the first body.

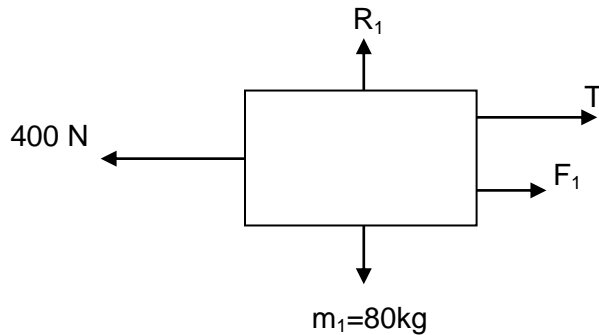

Fig 6.5

Let us consider the first body,  
 Let,  $T$  = tension in the thread  
 $R_1 = m_1 \cdot g = 80 \times 9.81 = 784$  N  
 $F_1 = \mu \cdot R_1 = 0.3 \times 784 = 235.2$  N  
 Resultant horizontal force  $P_1 = 400 - T - F_1 = 400 - T - 235.2 = 164.8 - T$  (towards left)  
 Force causing acceleration to first body, =  $m_1 \cdot a = 80 a$   
 As per D. Alembert's principle,  $P_1 - m_1 \cdot a = 0$

$$\Rightarrow 164.8 - T - 80a = 0$$

$$\Rightarrow T = 164.8 - 80a \dots\dots\dots (1)$$

Considering the second body,  
 $R_2 = m_2 \cdot g = 20 \times 9.81 = 196$  N  
 $F_2 = \mu \cdot R_2 = 0.3 \times 196 = 58.8$  N (towards right)  
 $P_2 = T - F_2 = T - 58.8$   
 Force causing acceleration to the second body =  $m_2 \cdot a = 20 \cdot a$

Now, as per D. Alembert's principle,

$$P_2 - m_2 \cdot a = 0$$

$$\Rightarrow T - 58.8 - 20 a = 0$$

$$\Rightarrow T = 58.8 + 20 a \dots\dots\dots (2)$$

Equating equations (1) and (2) we get,

$$164.8 - 80 a = 58.8 + 20 a$$

$$\Rightarrow 100 a = 106$$

$$\Rightarrow a = \frac{106}{100} = 1.06 \text{ m/sec}^2$$

Tension in the thread  
 Substituting the value of  $a$  in equation (2), we get

$$T = 58.8 + 20 a$$

$$= 58.8 + (20 \times 1.06)$$

$$= 80 \text{ N}$$

fig 6.6



**EXAMPLE 6.5:** A man weighing 750 N stands on the floor of a lift. Find the pressure exerted on the floor when (a) the lift moves upwards with an acceleration of 3 m/sec<sup>2</sup> and (b) the lift moves downwards with an acceleration of 3 m/sec<sup>2</sup>.

**Solution:** (a) Dynamic equilibrium can be obtained by applying inertia force (ma) in downward direction.

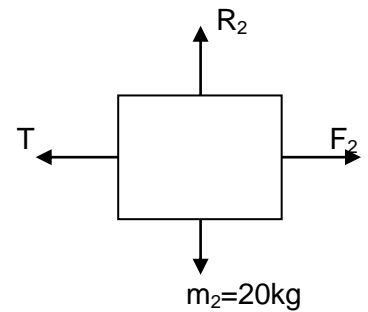
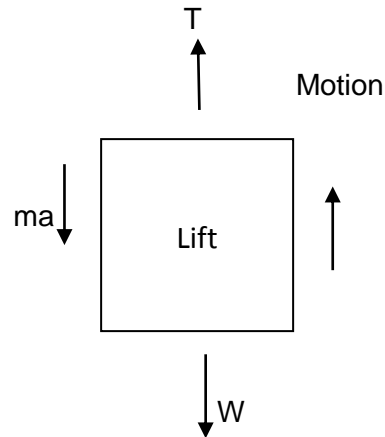

Fig 6.7

Now,  $T - ma - W = 0$

$$T = ma + W = ma + mg = \frac{W}{g}(a + g) = \frac{750}{9.81}(3 + 9.81) = 979.3578 \text{ N}$$

(b) Dynamic equilibrium can be obtained by applying the inertia force (ma) in upward direction.

$$T + ma - mg = 0$$

$$\Rightarrow T = mg - ma$$

$$= \frac{W}{g}(g - a)$$

$$= \frac{750}{9.81}(9.81 - 3)$$

$$= 520.64 \text{ N}$$

= Tension in the cable supporting the lift

= Reaction of the lift

= the pressure exerted by the man on the floor of the lift

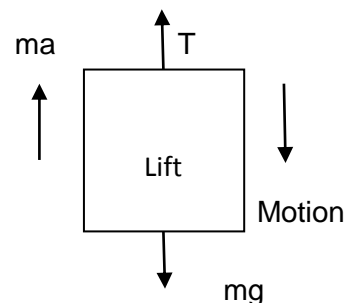

Fig 6.8

**EXAMPLE 6.6:** A bullet of 10 gm mass is fired horizontally with a velocity of 1000 m/sec from a gun of mass 50 kg. Find, (a) velocity with which the gun will recoil, and (b) force necessary to bring the gun to rest in 250 mm.

**Solution:** Given,  $m = 10 \text{ gm} = 0.01 \text{ kg}$

$$v = 1000 \text{ m/s}$$

$$M = 50 \text{ kg}$$

(a) We have,  $mv = MV$

$$\Rightarrow 0.01 \times 1000 = 50 \times V$$

$\Rightarrow V = 0.2 \text{ m/sec} = \text{Velocity of the recoil}$

(b) Initial velocity of the gun ( $u$ ) = 0.2 m/s

Final velocity of the gun ( $v$ ) = 0

Here,  $s = 250 \text{ mm} = 0.25 \text{ m}$

We have,  $v^2 - u^2 = 2as$

$\Rightarrow 0^2 - (0.2)^2 = -2 \times a \times 0.25$  (retardation)

$\Rightarrow a = 0.08 \text{ m/sec}^2$

$F = Ma = 50 \times 0.08 = 4 \text{ N}$

**EXAMPLE 6.7: A body of mass 100 kg is moving at a speed of 20 m/sec. If the body is 50 m above the ground level, calculate the potential energy and kinetic energy of the body.**

**Solution:** Given,  $m = 100 \text{ kg}$

$v = 20 \text{ m/sec}$

$h = 50 \text{ m}$

Potential energy =  $mgh = 100 \times 9.81 \times 50 = 49050 \text{ J} = 49.050 \text{ KJ}$

Kinetic energy =  $\frac{1}{2}mv^2 = \frac{1}{2} \times 100 \times 20^2 = 20000 \text{ J} = 20 \text{ KJ}$

**EXAMPLE 6.8: A body of mass 50 kg was dropped vertically into water from a height of 25 m. The body moved down into the water by 2 m and then started rising. Estimate the average resistance of water neglecting the resistance of air.**

**Solution:** Given,  $m = 50 \text{ kg}$

$h = 25 \text{ m}$

Let,  $P = \text{average resistance of water}$

Potential energy of the body before dropping into water =  $mgh = 50 \times 9.81 \times 25 = 12262.5 \text{ N-m}$

Work done by average resistance of water = Average resistance of water  $\times$  Depth of the water  
 $= P \times 2 = 2P \text{ N-m}$

Total potential energy of the body = Work done by average resistance of water

$\Rightarrow 12262.5 = 2P$

$\Rightarrow P = 6131.25 \text{ N}$

**EXAMPLE 6.9: The kinetic energy of a body is 2500 KJ corresponding to a velocity of 700 m/sec. Estimate the loss in kinetic energy when its velocity is reduced to 450 m/sec.**

**Solution:** Given :  $K.E_1 = 2500 \text{ KJ} = 2500 \times 10^3 \text{ J}$

$v_1 = 700 \text{ m/sec}$

$v_2 = 450 \text{ m/sec}$

Let,  $m = \text{mass of the body}$

The K.E of the body corresponding to a velocity of 700 m/sec is given by:

$KE_1 = \frac{1}{2}mv_1^2 = \frac{1}{2}m(700)^2$

But  $2500 \times 10^3 = \frac{1}{2}m(700)^2$

$\Rightarrow m = 10.2 \text{ kg}$

When the velocity is reduced to 450 m/s, its KE is given by,

$KE_2 = \frac{1}{2}mv_2^2 = \frac{1}{2} \times 10.2 \times (450)^2 = 1032750 \text{ J} = 1032.75 \text{ KJ}$

$$\begin{aligned}\text{Now, loss in KE} &= \text{KE}_1 - \text{KE}_2 \\ &= 2500 - 1032.75 = 1467.25 \text{ KJ}\end{aligned}$$

**EXAMPLE 6.10:** A ball of mass 2 kg moving with a velocity of 2 m/s hits directly on a ball of mass 4 kg at rest. The first ball, after impinging, comes to rest. Find the velocity of the second ball after the impact and the coefficient of restitution.

**Solution:** Given, Mass of first ball ( $m_1$ ) = 2 kg  
 Initial velocity of first ball ( $u_1$ ) = 2 m/s  
 Mass of second ball ( $m_2$ ) = 4 kg,  
 Initial velocity of second ball ( $u_2$ ) = 0 (as it is at rest)  
 final velocity of first ball after impact ( $v_1$ ) = 0 (as, it comes to rest)

(a) Velocity of the second ball after impact.

Let  $v_2$  = Velocity of the second ball after impact.

According to law of conservation of energy,

$$\begin{aligned}m_1u_1 + m_2u_2 &= m_1v_1 + m_2v_2 \\ \Rightarrow 2 \times 2 + 4 \times 0 &= 2 \times 0 + 4 \times v_2 \\ \Rightarrow 4 + 0 &= 0 + 4v_2 \\ \Rightarrow 4 &= 4v_2 \\ \Rightarrow v_2 &= 1 \text{ m/sec}\end{aligned}$$

(b) Coefficient of restitution

Let  $e$  = Coefficient of restitution.

According to the law of collision of elastic bodies,

$$\begin{aligned}(v_2 - v_1) &= e(u_1 - u_2) \\ \Rightarrow (1 - 0) &= e(2 - 0) \\ \Rightarrow 1 &= e \times 2 \\ \Rightarrow e &= \frac{1}{2} = 0.5\end{aligned}$$

**EXAMPLE 6.11:** A ball overtakes another ball of twice its own mass and moving with  $\frac{1}{7}$  of its own velocity. If the coefficient of restitution between the two balls is 0.75, show that the first ball will come to rest after impact.

**Solution:** Let, Mass of the first ball ( $m_1$ ) =  $M$  kg  
 Mass of the second ball ( $m_2$ ) =  $2M$  kg

Initial velocity of first ball ( $u_1$ ) =  $U$

Initial velocity of second ball ( $u_2$ ) =  $\frac{U}{7}$

coefficient of restitution ( $e$ ) = 0.75

Let  $v_1$  = Velocity of the first ball after impact, and

$v_2$  = Velocity of the second ball after impact.

According to the law of conservation of momentum

$$\begin{aligned}m_1u_1 + m_2u_2 &= m_1v_1 + m_2v_2 \\ \Rightarrow MU + 2M \times \frac{U}{7} &= Mv_1 + 2Mv_2\end{aligned}$$

$$\Rightarrow \frac{9MU}{7} = Mv_1 + 2Mv_2$$

$$\Rightarrow \frac{9U}{7} = v_1 + 2v_2 \dots \dots \dots (1)$$

According to the law of collision of elastic bodies,

$$(v_2 - v_1) = e (u_1 - u_2) = 0.75 \left( U - \frac{U}{7} \right) = \frac{9U}{14}$$

$$\Rightarrow v_2 = \frac{9U}{14} + v_1$$

Putting this value of  $v_2$  in equation (1) we get,

$$\frac{9U}{7} = v_1 + 2 \left( \frac{9U}{14} + v_1 \right)$$

$$\Rightarrow \frac{9U}{7} = 3v_1 + \frac{9U}{7}$$

$$\Rightarrow v_1 = 0$$

Thus the first ball will come to rest after impact.

**EXAMPLE 6.12:** A ball is dropped from a height  $h_0 = 1$  m on a smooth floor. Knowing that the height of the first bounce is  $h_1 = 81$  cm, determine

- (a) coefficient of restitution, and
- (b) expected height  $h_2$  after the second bounce.

**Solution:** Height from which the ball is dropped ( $h_0$ ) = 1 m  
and height to which the ball rose after first bounce ( $h_1$ ) = 81 cm. = 0.81 m.

(a) Coefficient of restitution

Let  $e$  = Coefficient of restitution.

The velocity with which the ball impinges on the floor,

$$u = \sqrt{2gh_0} = \sqrt{2g \times 1} = \sqrt{2g} \text{ m/sec} \dots \dots \dots (1)$$

and velocity with which the ball rebounds,

$$v = \sqrt{2gh_1} = \sqrt{2g \times 0.81} = 0.9\sqrt{2g} \text{ m/sec} \dots \dots \dots (2)$$

The velocity with which the ball rebounds ( $v$ )

$$0.9\sqrt{2g} = e \sqrt{2g}$$

$$\therefore e = 0.9$$

(b) Expected height after the second bounce

Let  $h_2$  = Expected height after the second bounce.

The velocity with which the ball impinges second time,

$$u = 0.9\sqrt{2g} \text{ m/sec}$$

and velocity, with which the ball rebounds,

$$v = \sqrt{2gh_2}$$

The velocity with which the ball rebounds second time ( $v$ )

$$\sqrt{2gh_2} = eu = 0.9 \times 0.9\sqrt{2g} = 0.81\sqrt{2g}$$

$$\therefore 2gh_2 = (0.81)^2 \times 2g = 0.656 \times 2g$$

$$\Rightarrow h_2 = 0.656 \text{ m}$$

## EXERCISES

1. State the Laws of Motion.
2. Derive an expression for the tension in the cable supporting a lift when (i) it is going up, and (ii) it is coming down.
3. Explain the dynamic equilibrium of a rigid body in plane motion
4. Define the coefficient of restitution.
5. State Newton's law of collision of elastic bodies.
6. Explain the law of conservation of linear momentum
7. Explain the law of conservation of energy
8. A body of mass 40 kg is moving with a constant velocity of 2.5 m/s. Now a force of 100 N is applied on the body in its direction of motion. What will be its velocity after 2 second. **(Ans. 7.5 m/s)**
9. A constant force of 100 N is applied on a body of mass 50 kg at rest. Find the distance travelled by it in 12 seconds. **(Ans. 144 m)**
10. An elevator of mass 500 kg is ascending with an acceleration of  $3 \text{ m/s}^2$ . During this ascent, its operator whose mass is 70 kg is standing on the scale placed on the floor. What is the scale reading? What will be the total tension in the cables of the elevator during this motion? **(Ans.  $R_1 = 896 \text{ N}$ ;  $R_2 = 7296 \text{ N}$ )**
11. A lift has an upward acceleration of  $1 \text{ m/s}^2$ . Find the pressure exerted by the man of mass
12. 62.5 kg on the floor of the lift. If the lift had a downward acceleration of  $1 \text{ m/s}^2$ , find the pressure exerted by the man. Also find an upward acceleration of the lift, which would cause the man to exert a pressure of 750 N. **(Ans. 675 N ; 550 N ;  $2.2 \text{ m/s}^2$ )**
13. A bullet of mass 20 g is fired horizontally with a velocity of 300 m/s, from a gun carried in a carriage ; which together with the gun has mass of 100 kg. The resistance to sliding of the carriage over the ice on which it rests is 20 N. Find (a) velocity, with which the gun will recoil,(b) distance, in which it comes to rest, and (c) time taken to do so. **(Ans.  $v = 0.06 \text{ m/s}$ ;  $s = 9\text{mm}$  ; $t = 0.3\text{s}$ )**
14. A bullet of 10 gm mass is fired horizontally with a velocity of 1000 m/s from a gun of mass 50 kg. Find (a) velocity with which the gun will recoil, and (b) force necessary to bearing the gun to rest in 250 mm. **(Ans. 0.2 m/s ; 4 N)**
15. A ball of mass 2 kg impinges directly with a ball of mass 1 kg, which is at rest. If the velocity of the smaller mass after impact, be the same as that of the first ball before impact, find the coefficient of restitution **(Ans. 0.5)**
16. Two balls of masses 2 kg and 3 kg are moving with velocities 2 m/s and 3 m/s towards each other. If the coefficient of restitution is 0.5, find the velocity of the two balls after impact. **(Ans. 2.5 m/s ; 0)**
17. A bullet of mass 50 gm is fired into a freely suspended target of 2.5 kg. On impact, the target moves with a velocity of 2.5 m/s. Find the velocity of the bullet and the loss of kinetic energy, if the impact is perfectly inelastic. **(Ans. 127.5 m/s ; 398.4 kg-m)**

18. A ball is dropped from a height of 25 metres upon a horizontal floor. Find the coefficient of restitution between the floor and the ball, if it rebounds to a height of 16 metres. (**Ans.** 0.8)
19. A heavy elastic ball drops from the ceiling of a room, and after rebounding twice from the floor reaches a height of equal to one-half of the ceiling. Show that the coefficient of restitution is  $(0.5)^{1/4}$ .

**References:**

1. Engineering Mechanics – by A.R. Basu (TMH Publication Delhi)
2. Text Book of Engineering Mechanics – R.S Khurmi (S. Chand).
3. Engineering Mechanics – By Timosheenko, Young & Rao.