

UGMIT RAYAGADA

Lecture Note

Of

LS-II, 6th Sem.

Prepared by

Soumya Ranjan

Maharana,

Lect. (Civil)

**LEARNING RESOURCE MATERIAL**

**ON**

**SURVEY-II**

**UNDER EDUSAT PROGRAMME**

**SCTE&VT, ODISHA, BHUBANESWAR**

## CONTENT

<b>Chapter No.</b>	<b>Topics</b>	<b>Page No.</b>	<b>Prepared by</b>
01	LEVELLING	2-32	Sri S. P. Mallik Sr. Lecturer Civil, GP, Sonapur
02	CONTOURING	33-43	-Do-
03	PRINCIPLES OF THEODOLITE SURVEYING	44-57	Sri N. R. Pattnaik Sr. Lecturer Civil, GP, Balasore
04	THEODOLITE TRAVERSING	58-72	-Do-
05	TACHEOMETRY	73-80	Sri E. Ekka, Sr. Lecturer Civil, GP, Berhampur
06	CURVES	81-95	-Do-
07	SETTING OUT WORKS	96-99	Sri D. Khura Sr. Lecturer Civil, GP, Jharsuguda
08	COMPUTER OF VOLUME	100-120	-Do-
09	MODERN SURVEYING METHODS	121-137	Dr. P.K. Mohanty, Principal, ITI, Dhenkanal

# CHAPTER-1

## 1.0 LEVELLING

**1.1 Purpose of levelling:** Levelling is the art of finding the relative heights and depths of the objects on the surface of the earth. It is that part of surveying which deals with the measurements in vertical plane.

Levelling is of prime importance to an engineer for the purpose of planning, designing and executing various engineering projects such as roads, Railways, canals, dams, water supply and sanitary schemes etc. The Principle of leveling lies in furnishing a horizontal sight and finding the vertical distances of the points above this line. This is done with the help of a level and a levelling staff respectively.

**1.2** Defination of terms used in levelling-concepts of level surface, Horizontal surface, Vertical surface, Datum, R.L, B.M.

**Level Surface:** This is a surface parallel to the mean spheroidal surface of the earth is said to be a level surface. The water surface of a still lake is also considered to be a level surface.

**Horizontal Plane/surface:** Any plane tangential to the level surface at any point is known as the horizontal plane. It is perpendicular to the plumb line.

**VerticalPlane/surface:** Any plane passing through the vertical line is known as the vertical Plane.

**Datum Surface or Line:** This is an imaginary level surface or level line from which the vertical distances of different points (above or below this line) are measured. In India the datum adopted for the Great Trigonometric Survey (GTS) is the mean sea level (MSL) at Karachi.

**Reduced Level (R.L):** The vertical distance of a point above or below the datum line is known as the reduced level of that point. The R.L of a point may be positive or negative according as the point is above or below the datum.

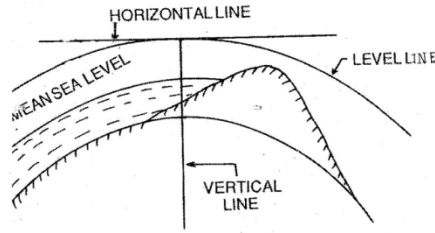

Figure 1.2a

**Bench Mark:** These are fixed points or marks of known RL determined with reference to the datum line. These are very important marks. They serve as reference points for finding the RL of new points or for conducting leveling operations in projects involving roads, Railways.

Bench mark are of four types. (a) **GTS (Great Trigonometric Survey) Bench mark:** This Bench mark s are established by Survey of India at large intervals all over the country (Mumbai). The values of Reduced levels, the relevant positions and the number of benchmarks are given in a catalogue published by this department (Ref. Fig: 1.2b )

(b) **Permanent Bench marks:** These are fixed points or marks established by different Government Departments like PWD, Railway, Irrigation, etc.. The R.L.'s of these points are determined with reference to the GTS bench mark., and kept on permanent points like the plinth of building, parapet of a bridge or culvert, and so on. Sometimes they are kept on underground pillars as in Fig: 1.2c

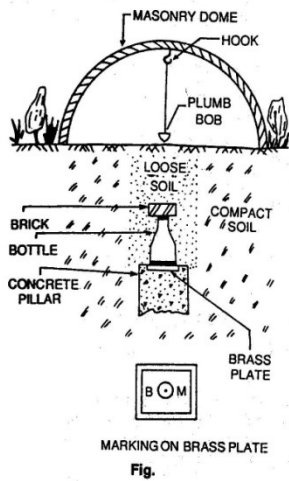

Figure 1.2b

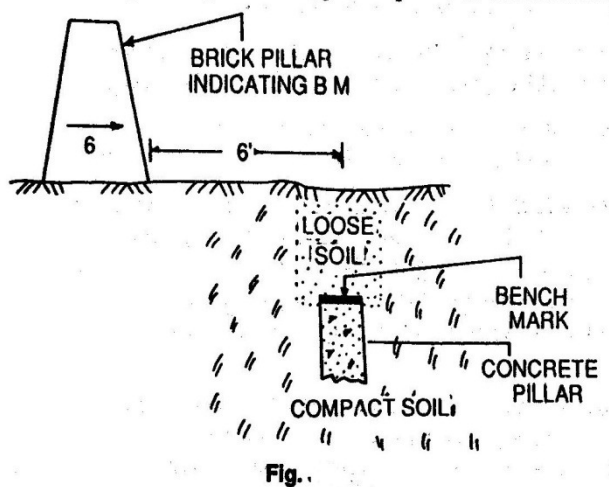

Figure 1.2c

**(c)Arbitrary Bench marks:** When the RL's of some fixed points are assumed, they are termed arbitrary bench-mars. These are adopted in small survey operations, when only undulation of the ground surface is required to be determined.

**(c)Temporary Bench marks:** When the bench marks are established temporarily at the end of a day's work, they are said to be temporary bench marks. They are generally made on the root of a tree, the parapet of a nearby culvert, a furlong post, or on a similar place.

**1.3:**Description of essential features and use of different types of leveling Instruments:Referring to Fig.

1,2,3-Three tripod legs,3a-triangular plate may be fixed on the top of tripod or detachable from the stand,(4),(5),(6) are three foot screws the foot screw(6)is not visible in the picture,(7) is a magnetic compass,(8) is a screw for holding a magnifying lens,(9)eye piece,(10)the object glass of the telescope covered by a detachable sun shade marked(11),(12)a milled headed screw is used for focusing known as focussing screw.(13) is one of the four capstan screws holding the cross hairs in the diaphragm,(14)main spirit level or longitudinal bubble with marked graduations,(15) a cross level which is smaller in size and is not graduated usually,(16)is, the triangular base,called leveling head(trivet),(17) Tribrach

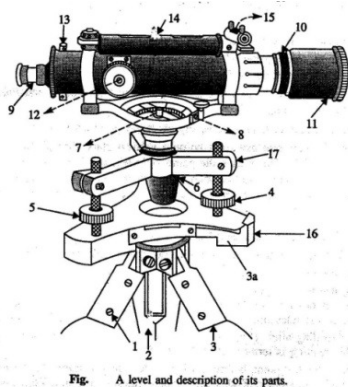

Fig. A level and description of its parts.

Figure 1.3a

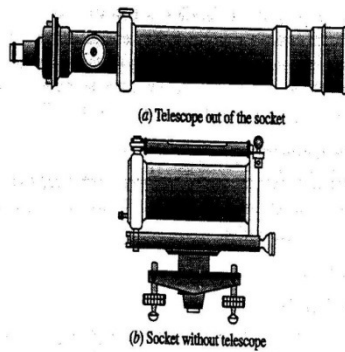

Fig. Cooke's Reversible level.

Fig.1.3b

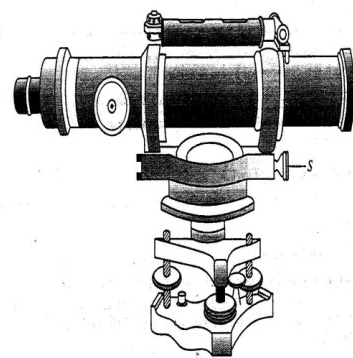

Fig. : Cushing's Reversible level.

Fig1.3c

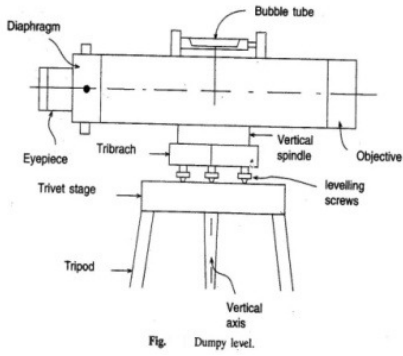

Fig. 1.3a

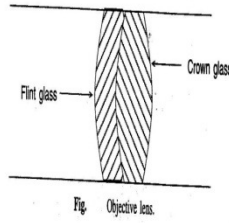

Fig. 1.3

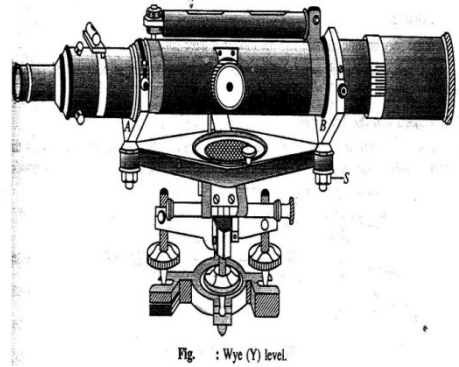

Fig. 1.3d

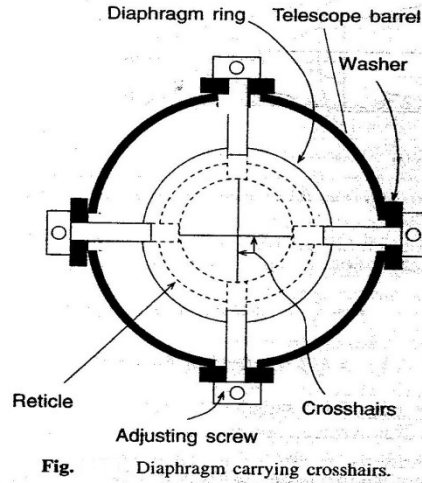

Fig. Diaphragm carrying crosshairs.

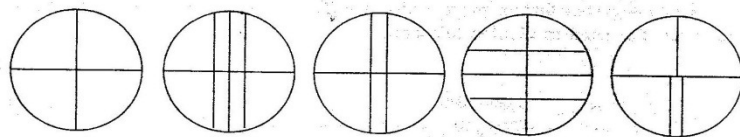

Fig. Different types of crosshairs.

Fig.1.3a

Modifications of dumpy level:Two modified forms of Dumpy level are(1)Cooke’s Reversible level and Cushing’s reversible level.

**Cooke’s reversible level:**The telescope is placed within a socket as such the telescope can be rotated about its longitudinal axis and (ii) can be taken out to be replaced with its ends interchanged in position,(iii)the axis of the telescope can be tilted a little about its transverse horizontal axis by operating the nut marked “S”.

**Cushing's reversible level:**(i) eye piece carrying the diaphragm and object glass are detachable and, thus, can be interchanged,(ii)Object glass and the eye piece can be rotated about the longitudinal axis of the telescope,(iii)The axis of the telescope can be tilted a little about the horizontal transverse axis of the telescope by operating the nut marked "S".

**Wye(Y) level:**Here the telescope is placed on Y support,(i)the telescope can be taken out of the socket and can be replaced with its ends reversed,(ii)the telescope can be rotated about its longitudinal axis,(iii)the telescope can be a little about its transverse horizontal axis by operating the nut marked "S"

**Tilting level:** The telescope can be tilted about its transverse horizontal axis by operating a screw called tilting screw.The line of collimation, thus can be made horizontal even when the vertical axis of the instrument is not truly vertical.Thus it saves time required for adjustment before taking the reading.

### **Modern levelling Instruments:**

**Automatic Levels:** The manual adjustment is eliminated in the use of auto level.A compensator mechanism is used in the functioning of this level. Only the telescope is approximately level,the compensator is active and the readings can be taken on the staff at different points.

**Electronic digital levels:**The level which eliminates the need to read the staff and record readings, modelDL100digital level,Sokkia's SDL30,TopconDL500series level are available.

**1.4:Concept of line of collimation:**It is an imaginary line passing through the intersection of the cross hairs at the diaphragm and the optical centre of the object glass and its continuation. It is also known as line of sight.

**Axis of the telescope:** This is an imaginary line passing through the optical centre of the object glass and the optical centre of the eye piece.

**Axis of the bubble tube:** It is an imaginary line tangential to the longitudinal curve of the bubble tube at its middle point.

**1.5:Levelling Staff,types features and use:** A level staff is a graduated rod of rectangular section. It is usually made of teak wood.It may also be fibre glass or metal.Two types of rod are:-



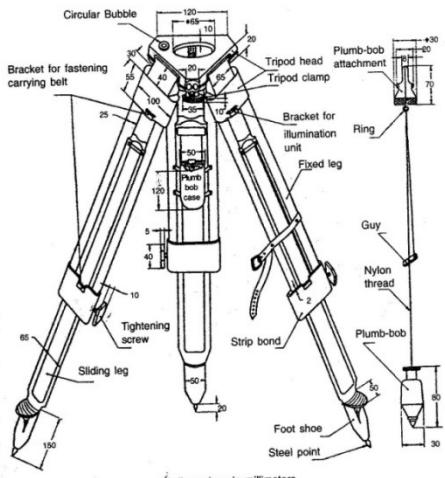

Fig. Dimensions and nomenclature of tripod for surveying instruments (adjustable leg).

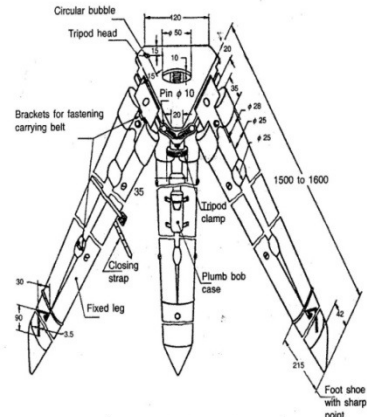

Fig. Dimensions and nomenclature for fixed leg tripod for surveying instruments.

Fig.1.5a

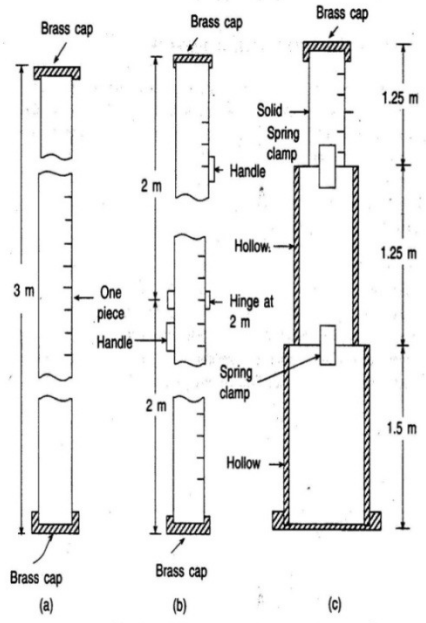

Fig. Different types of leveling staff.

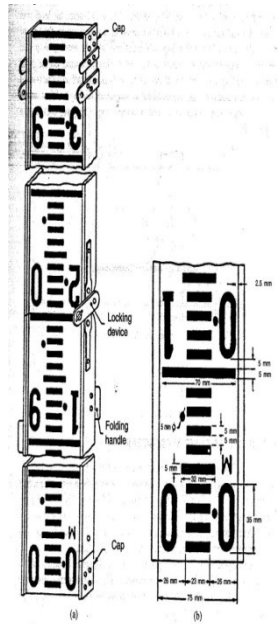

Fig. (a) Leveling staff (folding type). (b) Typical details of graduations.

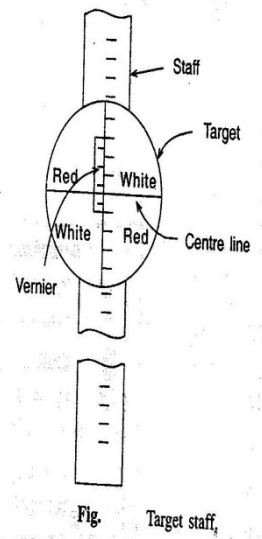

Fig. Target staff.

Fig.1.5b

1)Self-reading which can be read by the instrument operator with sighting through the telescope and noting the apparent intersection of the cross wires on the rod. This is the most common type.

2)The target rods having a movable target that is set by a rod person at the position indicated by signals from the instrument-man.

A leveling staff can be of (a) Solid i.e of one piece, (b) Folding when it can be folded to smaller length, (c) Telescopic, when the staff can be shortened by putting one piece inside another. Solid staff being of one piece, gives more accurate reading. Folding staff is light and convenient to handle. As per IS-1779-1961, the width and thickness of the staff are 75mm and 18mm respectively. The staff can be folded to 2m length. To ensure the verticality the staff has a circular bubble of 25mm sensitivity. Each meter is divided into 200 sub-divisions, the thickness of the graduations being 5mm. In telescopic staff the topmost part is solid and the other two parts are hollow. The two top pieces when pulled up are kept in position by brass flat spring clamps at the back of each piece fixed at its lower end. While using the telescope staff care should be taken to ensure that the three parts are fully extended. The telescopic staff are is not as accurate as a folding staff because of slippage between the parts.

Target staff has sliding target equipped with vernier. It is used for long distance, when it becomes difficult to take staff readings directly. The target is a small metal piece of circular or oval shape about 125mm diameter. It is painted red and white in alternate quadrants. For taking reading the level man directs the staff man to raise or lower the target till it is bisected by the line of sight. The staff holder then clamps the target and take the reading.

### **1.6: Temporary adjustment of level, taking reading with level:**

**1. Setting up:** Initially the tripod is set up at a convenient height and the instrument is approximately leveled. Some instruments are provided with a small circular bubble on the tribrach to check the approximate levelling. At this stage the the leveling screw should be at the middle of its run.

**2. Levelling up:** The instrument is then accurately leveled with the help of leveling screws or foot screws. For instruments with three foot screws the following steps are to be followed.

a) Turn the telescope so that the level tube is parallel to the line joining any two leveling screws as shown in Fig.

b) bring the bubble to the centre of its run by turning the two leveling screws either both inwards or outwards. c) Turn the telescope through  $90^\circ$ , so that the level tube is over the third screw or on the line perpendicular to the line joining screws 1 and 2. Bring the bubble to the centre of its run by the third foot screw only rotating either clockwise or anticlockwise.

d) Repeat the process till the bubble is accurately centred in both these conditions.

e) Now turn the telescope through  $180^\circ$  so that it again parallel to leveling screws 1 and 2. If the bubble still remains central, the adjustment is all right. If not, the level should be checked for permanent adjustments.

**3.Focussing:**This is done in two steps.First step is focusing the eye piece.This is done by turning the eye piece either in or out until the crosshairs are sharp and distinct.This will vary from person to person as it depends on the vision of the observer.The next step is focusing the objective.This is done by means of the focusing screw where by the image of the staff is brought to the plane of the cross hairs.This is checked by moving the eye up and down when reading the crosshair does not change with the movement of the eye as the image and the cross hair both move together.

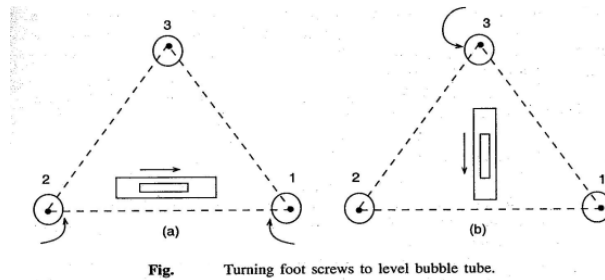

Fig.1.6

### 1.7: Concept of Bench Mark, BS, IS, FS, CP, HI:

**1.Station:**This is appoint where a leveling staff is held for taking observations with a level.

**2.Height of the Instrument(HI):**It means elevation of the line of sight or line of collimation with respect to the datum.

**3.Back Sight(BS):**It is the first reading taken at a station of known elevation after setting up of the instrument.This reading gives the height of Instrument(elevation of line of collimation),  

$$\text{elevation of line of collimation} = \text{Known elevation} + \text{backsight}$$

**4.Intermediate Sight(IS):**These are readings taken between the 1<sup>st</sup> and last reading before shifting the instrument to a new station.

**5.Fore Sight(FS):**This is the last reading taken before shifting an instrument to a new station.

**6.Turnig Point or Change Point:**For leveling over a long distance,the instrument has to be shifted a number of times.Turning point or change point connects one set of instrument readings with the next set of readings with the changed position of the Instrument.A staff is held on the turning point and a foresight is taken before shifting the instrument.From the next position of the instrument another reading is taken at the turning point keeping the staff undisturbed,which is known as back sight.

**7.Reduced Level(RL):**Reduced level of a point is its height relative to the datum. The Level is calculated or reduced with respect to datum.

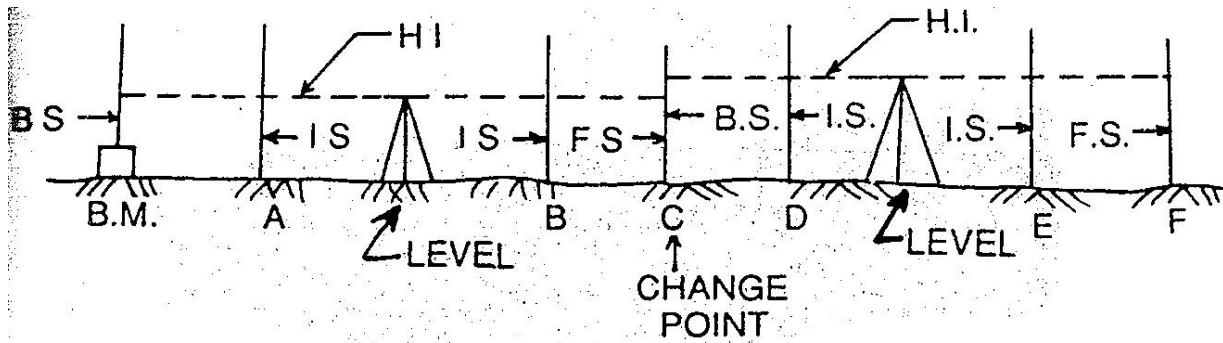

**Fig.**

Fig.1.7

**1.8:Principles of levelling:**

**a)Direct or simple levelling:**In levelling it is desired to find out the difference in level between two points.Then if the elevation of one point is known,the elevation of other point can be easily found out.In fig,the instrument is placed at C roughly midway between two points A and B.The staff readings are shown in figure.From the figure the R.L of B can be derived as  $100.50+1.51-0.57=101.44$ mm.From the reading it can also be observed that,if the second reading is smaller than the first reading, it means that the second point is at higher level than that the first.

**b) Trigonometrical levelling:** In trigonometrical leveling the difference in elevation is determined indirectly from horizontal distance and the vertical angle.It is used mainly to determine elevations of inaccessible points such as mountain peaks, top of towers etc. as shown in fig.

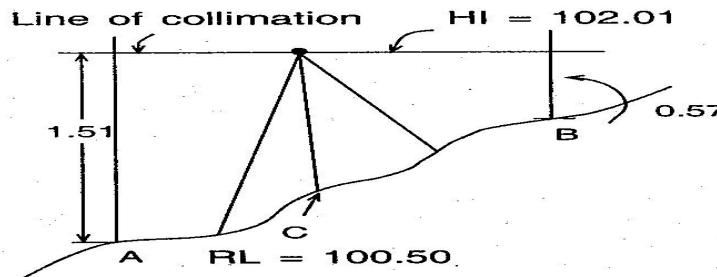

**Fig.** Direct levelling.

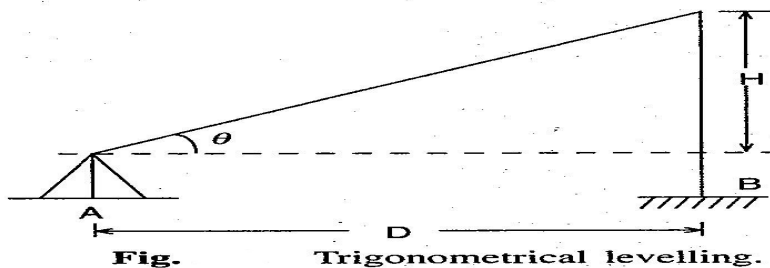

**Fig.** Trigonometrical levelling.

Fig.1.8

**c) Differential leveling:** This type of leveling is adopted when (i) the points are at a great distance apart, (ii) the difference in elevation between the points is large, (iii) there are obstacles between the points. This method is also known as compound levelling. In this method the level is set up at several suitable positions and staff readings are taken at all of these.

### 1.9: Field Data entry: Level book

#### A) Height of collimation or Height of Instrument method:

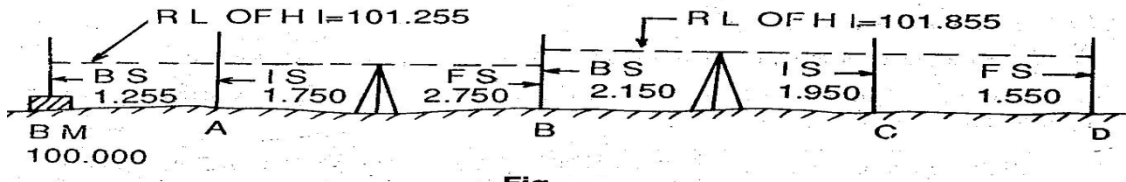

**Fig:1.9**

The reduced level of the line of collimation is said to be the height of instrument. In this system, the height of the line of collimation is found by adding the backsight reading to RL of the BM on which the BS is taken. Then the RL of the intermediate points and the change point are obtained by subtracting the respective staff readings from the height of Instrument (HI). The level is then shifted for the next set up and again the height of the line of collimation is obtained by adding the backsight reading to the RL of the change point (which is calculated in the first setup). So the ht. of instrument is different in different set ups of the level. Two adjacent planes of collimation. Two adjacent planes of collimation are correlated at the change point by an FS reading from one setting and a BS reading from the next setting. The RLs of unknown points are to be found out by deducting the staff readings from the RL of the height of instrument. Referring to Fig.

a) RL of HI in 1<sup>st</sup> setting =  $100.00 + 1.255 = 101.255$ , RL of A =  $101.255 - 1.750 = 99.505$ , RL of B =  $101.255 - 2.150 = 99.105$ , (b) RL of HI in 2<sup>nd</sup> setting =  $99.105 + 2.750 = 101.855$ , RL of C =  $101.855 - 1.950 = 99.905$ , RL of D =  $101.855 - 1.550 = 100.305$  and so on., Arithmetic check:  $\sum BS - \sum FS = \text{Last RL} - 1^{\text{st}} \text{RL}$ . The difference between the sum of backsights and that of foresights must be equal to the difference between the last RL and the first RL. This check verifies the calculation of the RL of the HI and that of the change point. There is no check on the RLs of the intermediate points.

**B) The Rise and Fall method:** In this method, the difference in level between two consecutive points is determined by comparing each forward staff reading with the staff reading at the immediately preceding point. If the forward staff reading is smaller than the immediately preceding staff reading, a rise is said to have occurred. The rise is added to the RL of the preceding point to get the RL of the forward point. If the forward staff reading is greater than the immediately preceding staff reading, it means there has been a fall. The fall is subtracted from the RL of the preceding point to get the RL of the forward point. Refer. to Fig.

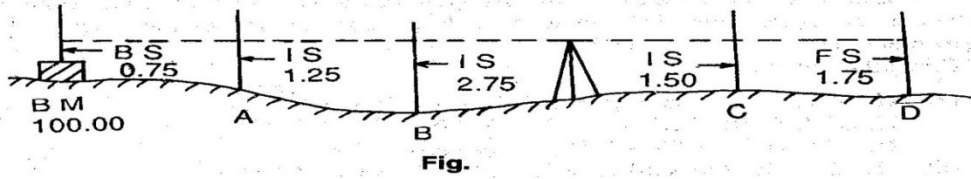

Fig.1.9

Point A(with respect to BM)=0.75-1.25=-0.50(Fall), Point B(with respect to A)=1.25-2.75=-1.50(Fall),

Point C(with respect to B)=2.75-1.50=+1.25(Rise),Point D(with respect to C)=1.50-1.75=-0.25(fall)

RL of BM=100.00,RL of A=100.00-0.50=99.50, RL of B=99.50-1.50=98.50, RL of C=98.00+1.25=99.25, RL of D=99.25-0.25=99.00

Arithmetic Check: $\sum BS - \sum FS = \sum Rise - \sum Fall = Last RL - 1st RL$

In this method,the difference between the sum of BS's and that ofFS's,the difference between the sum of rises and that of falls and the difference between the Last RL, and the first RL must be equal.

*Note:The arithmetical check is ment only for the accuracy of calculation to be verified.It does not verify the accuracy of field work.There is a complete check on the RLs of the intermediate points in the rise and fall system.*

### Comparison of the two systems:

Sl.No.	Collimation System	Rise and fall system
1.	It is rapid as it involves few calculation	It is labourious,involving several calculations
2.	There is no check on the RL of intermediate points	There is a check on the RL of intermediate points
3.	Errors in immediate RLs cannot be detected	Errors in immediate RLs can be detected as all the points are correlated
4.	There are two checks on the accuracy of RL calculation	There are three checks on the accuracy of RL calculation
5.	This system is suitable for longitudinal levelling where there are a number of intermediate sights.	This system is suitable for fly levelling where there are no intermediate sights.

### Points to be remembered while entering the level Book:

1.The first reading of any support is entered in the BS column,the last reading in the FS column and the other readings in the IS column.

2. A page always starts with BS and finishes with an FS reading.

3. If a page finishes with an IS reading, the reading is entered in the IS and FS columns on that page and brought forward to the next page by entering it in the BS and IS columns.

4. The FS and BS of any change point are entered in the same horizontal line.

5. The RL of the line of collimation is entered in the same horizontal line in which the corresponding are entered.

6. Bench Mark(BM) and change point(CP) should be clearly described in the remark column.

**Example:** The following consecutive readings were taken with a dumpy level along a chain line at a common interval of 15m. The first reading was at a chainage of 165m, where RL is 98.085. The instrument was shifted after the fourth and ninth readings: 3.50, 2.245, 1.125, 0.860, 3.125, 2.760, 1.835, 1.470, 1.965, 1.225, 2.390 and 3.035

Mark rules on a page of your note book in the form of a level book page and enter on it the above readings and find the RL of all the points by: (1) The line of Collimation method, (2) The Rise and fall method & apply the usual checks.

(1) The line of Collimation method:

Station point	Chainage	BS	IS	FS	RL of Line of collimation(HI)	RL	Remarks
1	165	3.150	xxxx	xxxx	101.235	98.085	
2	180	xxxx	2.245	xxxx	xxxx	98.990	
3	195	xxxx	1.125	xxxx	xxxx	100.110	
4	210	3.125	xxxx	0.860	103.500	100.375	Change Point
5	225	xxxx	2.760	xxxx	xxxx	100.740	
6	240	xxxx	1.835	xxxx	xxxx	101.665	
7	255	xxxx	1.470	xxxx	xxxx	102.030	
8	270	1.225	xxxx	1.965	102.760	101.535	Change Point
9	285	xxxx	2.390	xxxx	xxxx	100.370	
10	300	xxxx	xxxx	3.035	xxxx	99.725	
<b>TOTAL=</b>		<b>7.500</b>	xxxx	<b>5.860</b>	xxxx	xxxx	

Arithmetic Check:  $\sum BS - \sum FS = \text{Last RL} - 1^{\text{st}} \text{RL}$ ,  $(7.500 - 5.860) = +1.640$ ,  $(99.725 - 99.085) = +1.640$

2) The Rise and fall method:

Station point	Chainage	BS	IS	FS	Rise(+)	Fall(-)	RL	Remarks
1	165	3.150	xxxx	xxxx	xxxx	xxxx	98.085	
2	180	xxxx	2.245	xxxx	0.905	xxxx	98.990	

3	195	xxxx	1.125	xxxx	1.120	xxxx	100.110	
4	210	3.125	xxxx	0.860	0.265	xxxx	100.375	ChangePoint
5	225	xxxx	2.760	xxxx	0.365	xxxx	100.740	
6	240	xxxx	1.835	xxxx	0.925	xxxx	101.665	
7	255	xxxx	1.470	xxxx	0.365	xxxx	102.030	
8	270	1.225	xxxx	1.965	xxxx	0.495	101.535	ChangePoint
9	285	xxxx	2.390	xxxx	xxxx	1.165	100.370	
10	300	xxxx	xxxx	3.035	xxxx	0.645	99.725	
<b>TOTAL=</b>		<b>7.500</b>	<b>xxxx</b>	<b>5.860</b>	<b>3.945</b>	<b>2.305</b>	<b>xxxx</b>	

$\sum BS - \sum FS = 7.500 - 5.860 = +1.640$ , Last RL - 1<sup>st</sup> RL = (99.725 - 98.085) = +1.640,

$\sum Rise - \sum Fall = 3.945 - 2.305 = +1.640$

**Exercise No.1:** The following figures are staff readings taken in order on a particular scheme, the backsights being 0.813, 2.170, 2.908, 2.630, 3.133, 3.752, 3.277, 1.899, 2.390, 2.810, 1.542, 1.274, 0.643. The first reading was taken on a bench mark 39.563. Enter the readings in level book form, check the entries, and find the reduced level of the last point. Comment on your completed reduction.

**Exercise No.2:** A page of an old level book had been damaged by white ants and the readings marked X are missing. Find the missing readings with the help of available readings and apply arithmetical checks.

Distance in m	BS	IS	FS	RL of Line of collimation (HI)	RL	Remarks
	X			X	209.510	B.M
0		1.675			X	
30		X			210.425	
60		3.355			209.080	
X	0.840		X	209.520	X	Change Point
120		X			208.275	
150		X			210.635	Underside of bridge girder
X	X		2.630	X	X	X
210		X			206.040	
240		1.920			205.895	
270			X		205.690	

### 1.10: Different types of levelling, uses and methods:

**1) Differential or Fly Levelling:** It is carried out when the difference in elevation between two points that are far apart is to be determined. Here there is no need to determine the RLs of the intermediate points. This method is adopted when one wants to establish a bench mark near the



site of leveling work. Essentially, Backsights and foresights are taken to reach a point B starting from a point A. This relates the R.L of point B with the known RL of point A. (Ref: Fig.)

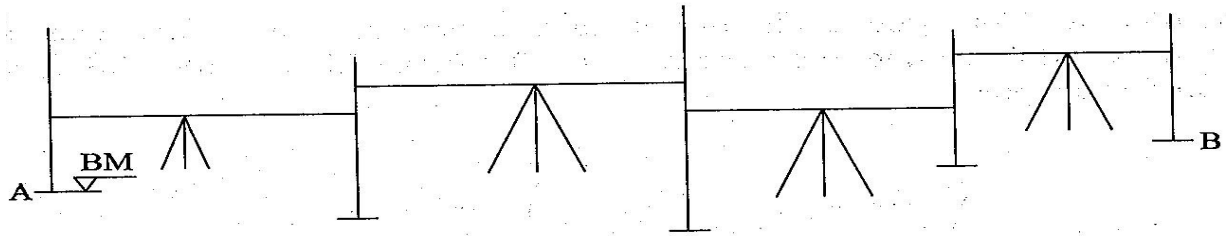

**Fig** Differential or fly levelling

Fig.1.10

**Example:**

Station point	BS	IS	FS	Rise(+)	Fall(-)	RL	Remarks
BM	0.955	xxxx		xxxx	xxxx	250.550	on BM No.1
	1.250	xxxx	2.150		1.195	249.355	
	0.785	xxxx	1.760		0.510	248.845	
	1.535	xxxx	2.055		1.270	247.575	ChangePoint
	1.260	xxxx	0.835	0.700	xxxx	248.275	
	0.675	xxxx	0.955	0.305	xxxx	248.580	
	1.275	xxxx	1.505		0.830	247.750	
	1.675	xxxx	2.050	xxxx	0.775	246.975	ChangePoint
	0.450	xxxx	2.160	xxxx	0.505	246.470	
A	xxxx	xxxx	1.005	xxxx	0.555	245.915	Starting point of road project
<b>TOTAL=</b>	<b>9.840</b>	<b>xxxx</b>	<b>14.475</b>	<b>1.005</b>	<b>5.640</b>	<b>xxxx</b>	

$$\sum BS - \sum FS = 9.840 - 14.475 = -4.635, \text{ Last RL} - 1^{\text{st}} \text{ RL} = (245.915 - 250.550) = -4.635,$$

$$\sum Rise - \sum Fall = 1.005 - 5.640 = -4.635$$

**2) Check Levelling:** It is the operation done to check the leveling work done. A simple method is to run a series of levels as in fly leveling up to the starting point of the survey at the end of the day. This will check the accuracy of the leveling work.

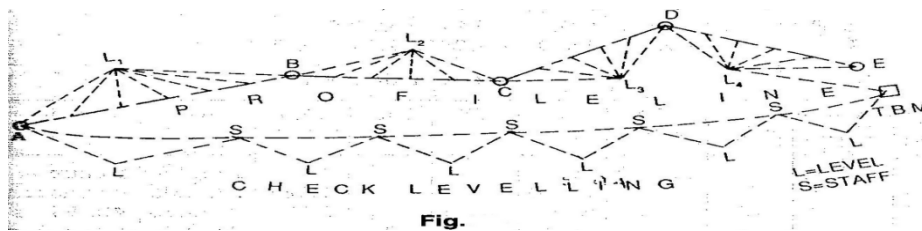

**Fig.**

Fig:1.10

**3) Profile Levelling:** Profile leveling or sectioning is leveling done across a line, e.g., along the centre line of the road, to get a sketch of the profile. Essentially the staff stations have to be ranged to be along a line. Readings are taken on the staff held along this line. When the levels are plotted along the distances in a line, we get a profile of the ground showing the elevations of the points. (Ref. Fig.)

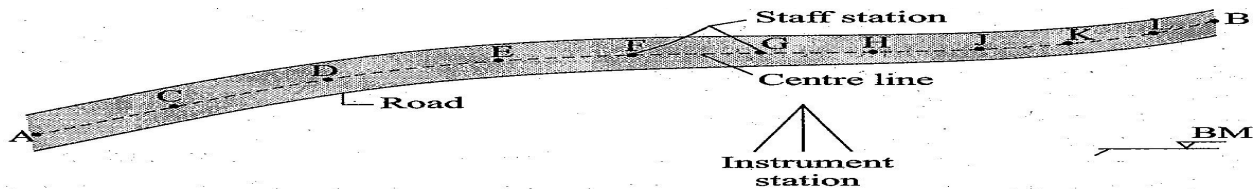

Fig. Profile levelling

Fig:1.10

**4) Cross sectioning:** It involves taking levels across a line, e.g. the centre line of a road, or a railway line. Depending upon the width of road, a number of staff stations are fixed across the centre line. This again gives a profile perpendicular to the longitudinal line and is useful in calculating the volume, etc.

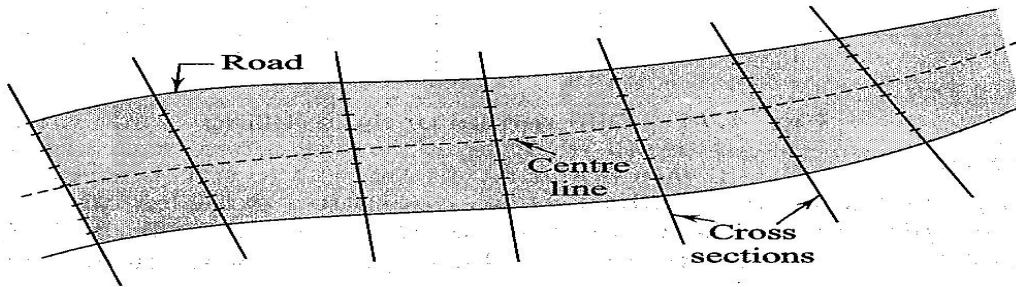

Fig. Cross-sectioning

Fig:1.10

**5) Reciprocal Levelling:** Reciprocal levelling is done when the distances are long and it is not possible to balance the lengths of the line of sights. This happens, e.g., in the case of points lying on either side of a river, when it is not possible to maintain the level between the two points. This process eliminates many errors due to maladjustment of the instrument and those due to curvature and refraction.

**1.11: Plotting of profiles: a) Longitudinal sections:**

For plotting normally the Horizontal scale of 1:1000 or 1:2000 and vertical scale which is of either 1:100 or 1:200 is followed. A horizontal line is drawn as the datum line. The chainages are marked along this line according to the horizontal scale. Then the ordinates (perpendicular lines) are drawn at each of the chainage points. The RL of the datum line is assumed in such a

way that the ground surface can be shown above the datum. Now the vertical distances (RL of GL-RL of datum) are plotted along the ordinates according to the vertical scale. The plotted points are joined to obtain the outline of the ground surface (as shown in fig.). The formation line are drawn in Red ink.

a) **Cross sections:** The cross sections are drawn/plotted in the same way as of longitudinal sections, but the Horizontal and vertical scales are slightly different (Horiz. 1:400, Vert. 1:100 are normally followed)

**Example of profile levelling:**

Station	Chainage	Bearing		Readings			Rise (+)	Fall (-)	RL	Remark
		FB	BB	BS	IS	FS				
A	0	AB = 80°30'		1.525					245.915	Starting point of project C/S-1
	20				2.150			0.625	245.290	
	40				2.650			0.500	244.790	C/S-2
	60			0.950		0.850	1.800		246.590	CP
	80				2.055			1.105	245.485	C/S-3
	100				1.965		0.090		245.575	
B	115	BC = 120°30'	AB = 260°30'	1.305		1.255	0.710		246.285	CP
	120				1.850			0.545	245.740	C/S-4
	140				2.360			0.510	245.230	
	160			1.055		0.755	1.605		246.835	CP C/S-5
	180				1.860			0.805	246.030	
	200				2.950			1.090	244.940	
C	220	CD = 30°15'	BC = 300°30'	0.890		1.155	1.795		246.735	CP C/S-6
	240				1.755			0.865	245.870	
	260				2.680			0.925	244.945	
D	280	DE = 140°0'	CD = 210°15'	1.350		1.270	1.410		246.355	C/S-7
	300				2.105			0.755	245.600	
	320				2.655			0.550	245.050	C/S-8
	340				3.250			0.595	244.455	
E	360		DE = 320°0'		1.760		1.490		245.945	C/S-9
TBM						0.715	1.045		246.990	TBM kept on top of well

**Cross-section 1 at chainage 0**

Distances			BS	IS	FS	Rise	Fall	RL	Remark
Left	Centre	Right							
	0		0.760					245.915	Centre at chainage 0. RL is taken from longitudinal section
		5		1.875			1.115	244.800	
		10		2.360			0.485	244.315	
		15		0.985		1.375		245.690	
		20		0.375		0.610		246.300	
5				2.015			1.640	244.660	
10				1.550		0.465		245.125	
15				0.790		0.760		245.885	
20					1.525		0.735	245.150	
Summation =			0.760		1.525	3.210	3.975		

**Cross-section 2 at chainage 40**

Distances			BS	IS	FS	Rise	Fall	RL	Remark
Left	Centre	Right							
	0		1.035					244.790	Centre at chainage 40. RL is taken from longitudinal section
		5		2.620			1.585	243.205	
		10		3.155			0.535	242.670	
		15		1.935		1.220		243.890	
		20		0.760		1.175		245.065	
5				1.875			1.115	243.950	
10				2.620		0.770	0.745	243.205	
15				1.850		0.875		243.975	
20					0.975			244.850	
Total =			1.035		0.975	4.040	3.980		
Check =			$\Sigma BS - \Sigma FS = 1.035 - 0.975 = + 0.060$			$\Sigma Rise - \Sigma fall = 4.040 - 3.980 = + 0.060$		$= 244.850 - 244.790 = + 0.060$	

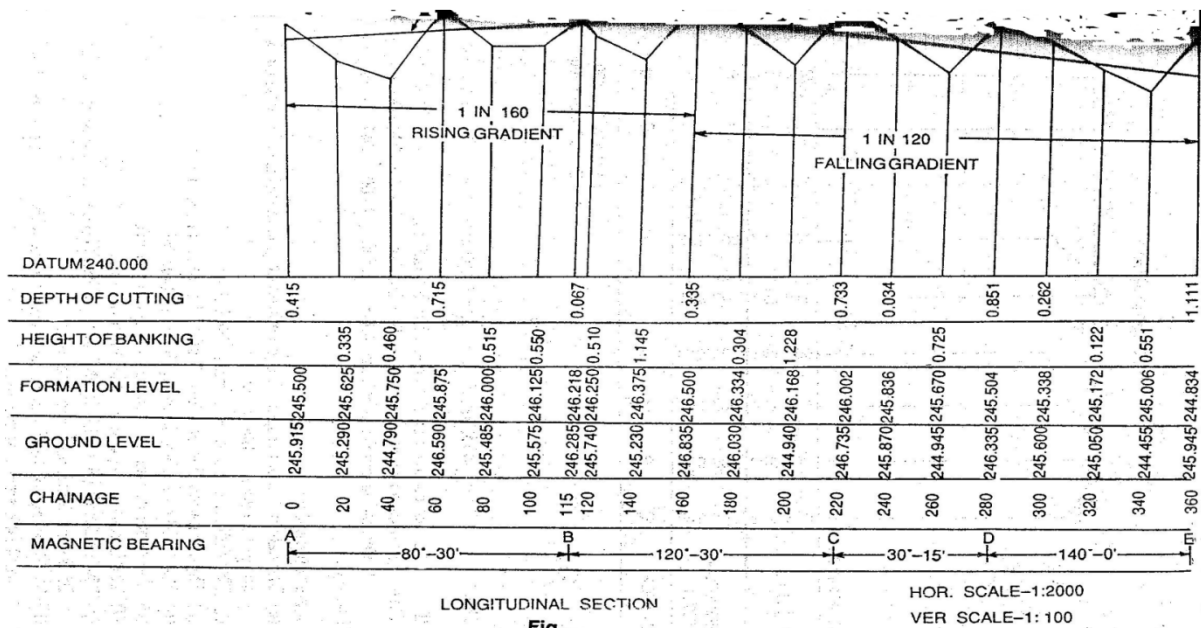

**Fig.**

**Fig.1.11**

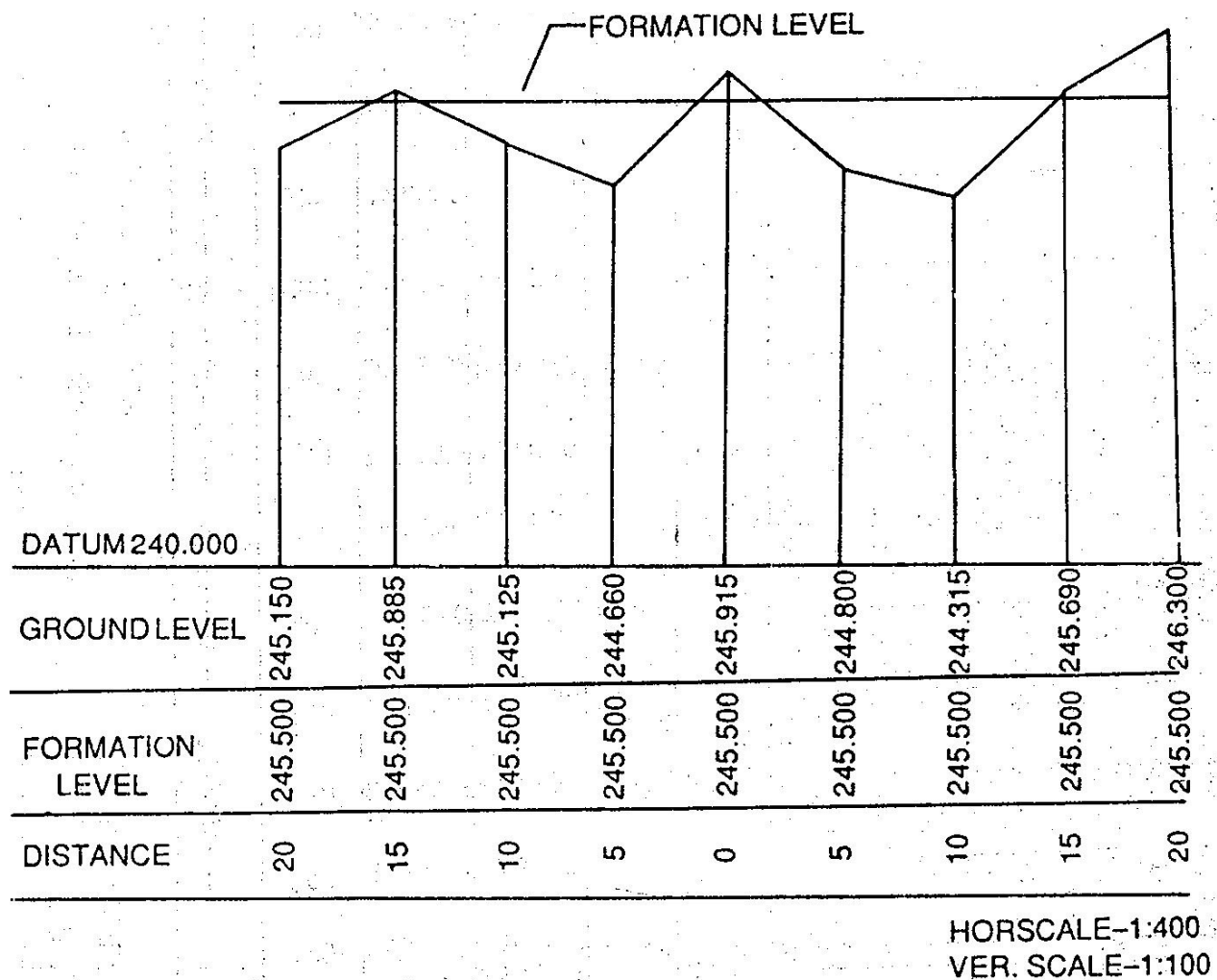

**Fig.**

Fig:1.11

### 1.12 Effects of Curvature and refraction:

Leveling instruments provide horizontal line of sight and as a result curvature error occurs. In addition due to refraction in earth's atmosphere the ray gets bent towards the earth introducing refraction errors. Fig. illustrates these errors. Neglecting small instrument Height SA, OA can be taken as the radius of earth, From Geometry of a circle,  $AB(2R+AB)=d^2$ , as AB is very small compared to diameter of the earth  $AB \cdot 2R = d^2$ ,  $AB = d^2/2R$ , The dia. Of earth is taken as 12734KM, Hence curvature correction:  $AB = d^2/12734\text{Km} = 0.078 d^2 \text{ m}$ ,  $d$  is expressed in Km. The radius of ray IC is bent due to refraction is taken as seven times the radius of earth. The refraction correction is taken as  $1/7^{\text{th}}$  of the curvature correction. Refraction correction reduces the curvature

correction and hence combined correction is  $\frac{6}{7}$ th of  $0.078d^2m$ , i.e.  $0.067d^2$  and  $d$  is expressed in Km. The correction is subtractive from staff reading.

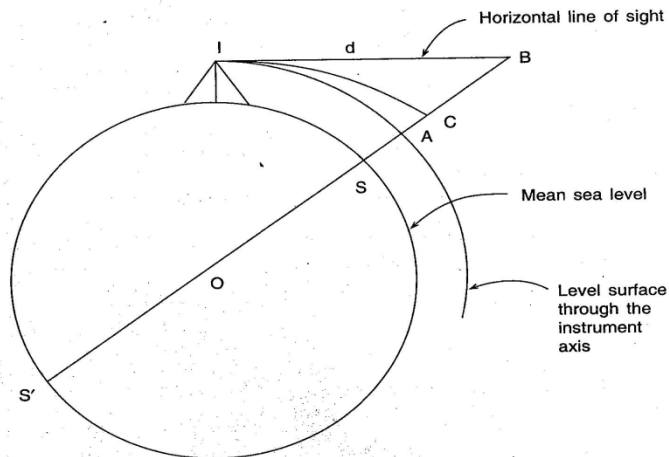

**Fig.** Curvature and refraction correction:  $I$  = instrument station;  $S$  = staff station;  $AB$  = curvature error;  $BC$  = error due to refraction;  $AC$  = combined error due to curvature and refraction;  $SB$  = staff normal to earth's surface;  $IB = d$ , distance of the staff from the instrument.

Fig.1.12

**Example:** Determine the distance for which the combined correction is 5mm.

Correction in  $m = 0.067d^2$  where  $d$  is in Km,  $d^2 = 0.005 / 0.067$ ,  $d = \sqrt{0.005 \div 0.067}$   
 $= 0.273 \text{ Km} = 273 \text{ m}$

**Exercise:** A sailor standing on the deck of a ship just sees the top of a light house. The top of the light house is 30m above sea level and the height of sailor's eye is 5m above sea level. Find the distance of the sailor from the light house.

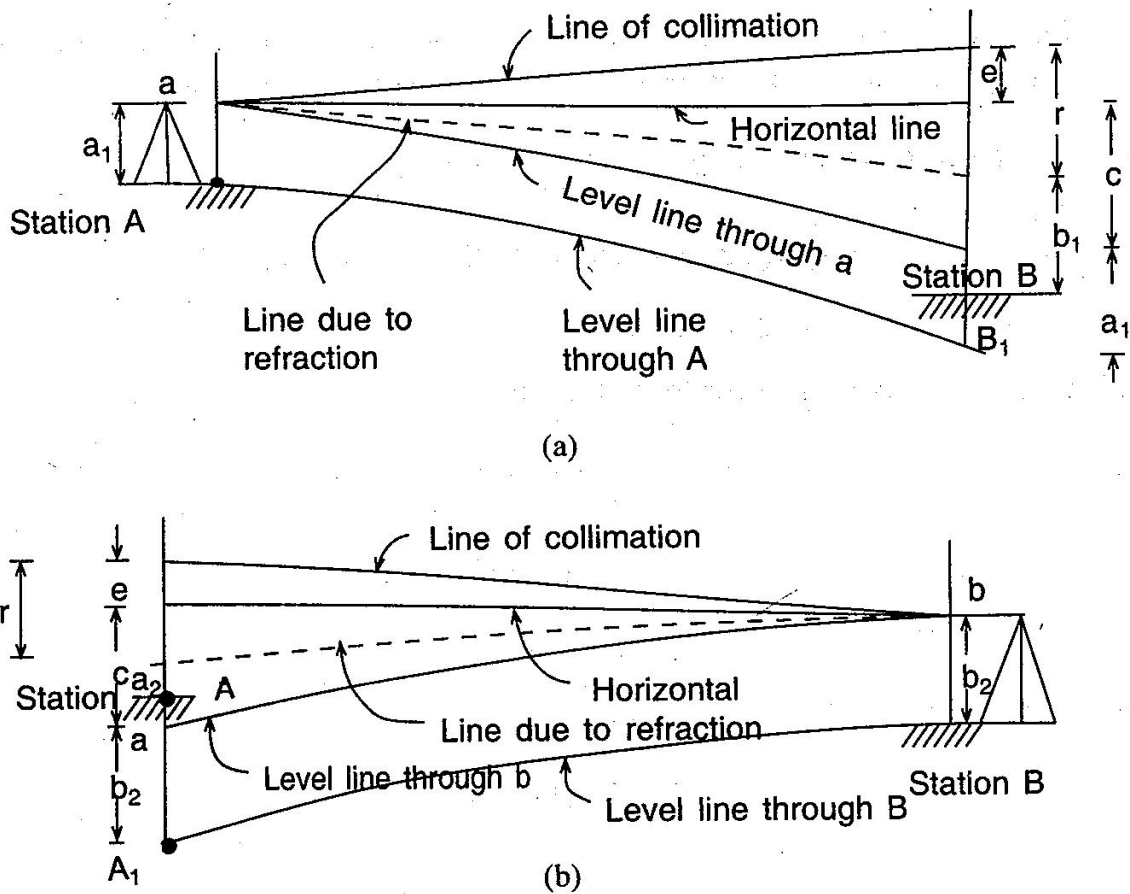

Fig:1.13

### 1.13 Reciprocal levelling:

While crossing a river or ravine it is not possible to put the level midway so that the back sight and foresight are equal. Sight distance, however, is long and errors due to (i) collimation, (ii) curvature and refraction are likely to occur. To avoid these errors two observations are made. As shown in fig. instrument is placed near station A and observations are made on staffs at A and B. Similarly instrument is placed near B and staff readings are taken on B and A.

From 1<sup>st</sup> set of reading: difference in level =  $d = BB_1 = a_1 + c + e - r - b_1 = (a_1 - b_1) + (c - r) + e$

From 2<sup>nd</sup> set of reading: Difference in level =  $d = AA_1 = -(b_2 + c + e - r - a_2) = (a_2 - b_2) - (c - r) - e$  (sign as difference is measured at A instead of at B). By adding:  $2d = (a_1 - b_1) + (a_2 - b_2)$ , or,  $d = \frac{1}{2}[(a_1 - b_1) + (a_2 - b_2)]$ ,

Subtracting,  $2(c - r) + e = [(a_2 - b_2) - (a_1 - b_1)]$ , or  $(c - r) + e = \frac{1}{2}[(a_2 - b_2) - (a_1 - b_1)]$ , C = curvature error, r = refraction error, e = error due to collimation.

**Example:**The results of reciprocal leveling between station A and B 250m apart on opposite sides of a wide river were as follows.

Level at A ----- ht. of eye piece(m)1.399 -----staff reading2.518 on B

Level at B ----- ht. of eye piece(m)1.332 -----staff reading0.524 on A

Find the true difference of level between the stations.and the error due to imperfect adjustment of the instrument assuming the mean radius of earth6365Km.

Solution:Since the staff is very close to A and B in 1<sup>st</sup> and 2<sup>nd</sup> set up respectively,the height of the eye piece is taken as the staff reading.True difference of level= $\frac{1}{2}[(a_1-b_1) + (a_2-b_2)] = \frac{1}{2}[(1.399-2.518)+(0.524-1.332)] = -0.964\text{m}$ ,Indicating that A is at lower level than B.

Total error= $\frac{1}{2}[(a_2-b_2)-(a_1-b_1)] = \frac{1}{2}[(-0.808)-(-1.119)] = +0.156\text{m}$ ,Error due to curvature and refraction= $L^2/2R[1-2m] = 0.00422\text{m}$ ,Error due to collimation= $+0.156-0.004 = +0.152$  in 250m,Hence error/100m= $+0.06\text{m}$

**Precise leveling:**Precise levelling aims at establishing the RL of a point with highest precision.The objective of providing such high order of precision in the measurement is to establish network of Bench marks.Precise leveling employs precise level,precise leveling staff and all possible corrections in order to attain accuracy of highest order in the Instrument.

**Field Work:**1)Back sights and fore sights are taken with instrument equidistant from the staffs for eliminationof collimation errors,error due to curvature and refraction.(2)More than one setting at the same instrument position will help in the reduction of error.(3)Reading in the staff are taken in three levels of stadia hairs.

### 1.14Difficulties in leveling:

**1.When the staff is too near the staff:**if the staff is held very near the leveling instrument, the graduations of the staff are not visible.In such acse a piece of paper is moved up and down along the staff until the edge of the paper is bisected by the line of collimation.Then the reading is noted from the staff with nacked eye.Sometimes the reading is taken by looking through the object glass.

**2.Levelling across a large pond or lake:**As the water surface is level,all the points on it will have the same RL.Two pegs A and B are fixed on opposite banks of the lake or Pond.The tops of the pegs are just flush with the water surface.The level is set up at O<sub>1</sub>and the RL of A is determined by taking the FS on A.The RL of B is assumed to be equal to that of A. Now the level is shifted and set up at O<sub>2</sub>.Then by taking the BS on Peg B,leveling is continued (Ref:Fig.)



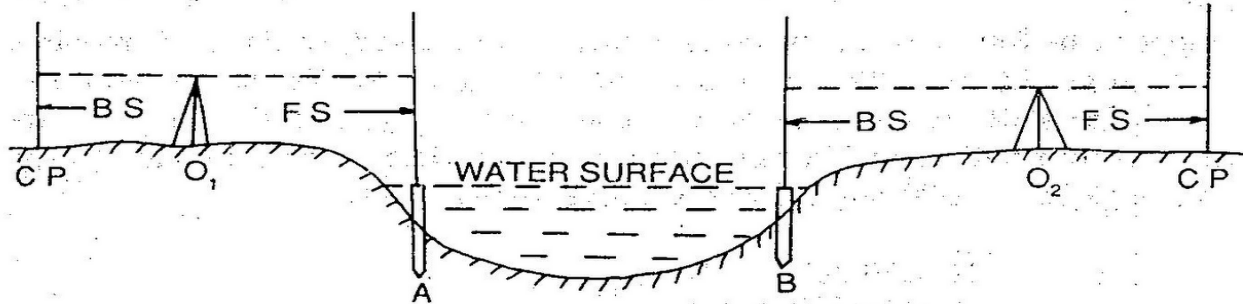

Fig.

Fig:1.14

**3. Levelling across a River:** In case of a flowing water the surface cannot be considered to be level. The water levels on opposite edges will be different. In this case the method of Reciprocal leveling is followed.

**4. Levelling across a Solid wall:** When leveling is carried across a brick wall, two pegs A and B are driven on either side of the wall just touching it. The level is setup at  $O_1$  and a staff reading is taken on A. Let this reading be  $A_c$ . Then the height of the wall is measured by staff. Let the ht. be  $AE$ . The HI is found out by taking a BS on any BM or CP. Then  $RL\ of\ A = HI - A_c$ ,  $RL\ of\ E = RL\ of\ A + AE = RL\ of\ F$  (Same level). The level is shifted to some point  $O_2$ . The staff reading  $B_d$  is noted and the Ht. measured. Thus  $RL\ of\ B = RL\ of\ F - B_d$ ,  $HI\ at\ O_2 = RL\ of\ B + B_d$ . The leveling is then continued by working out the HI of the setting (Ref. Fig)

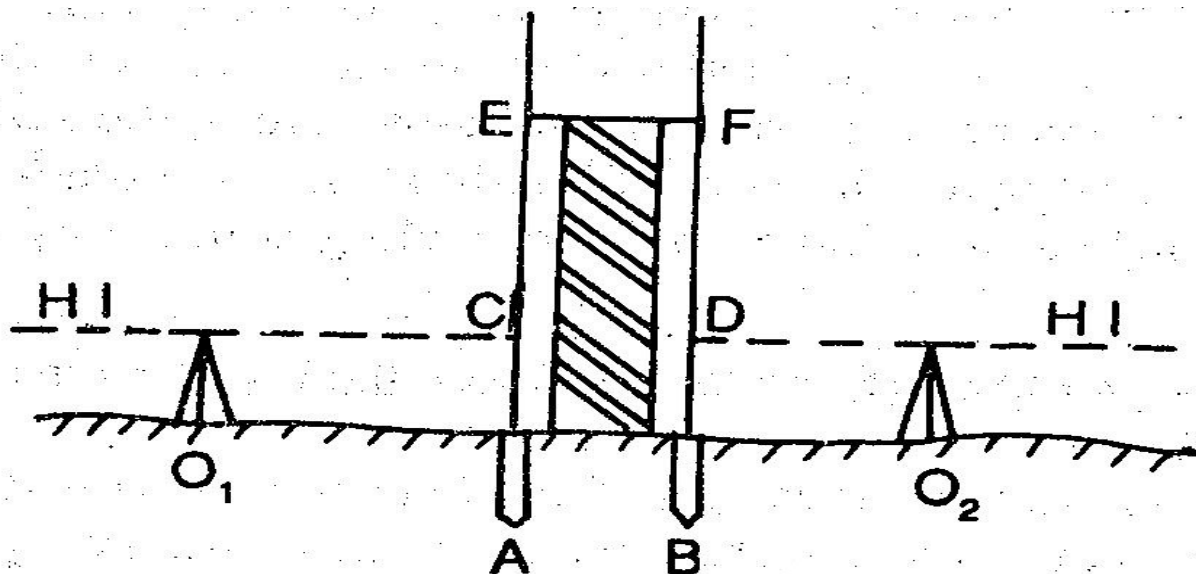
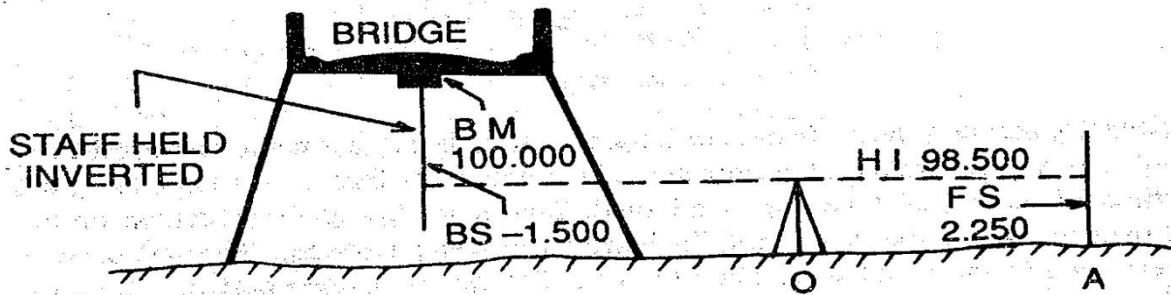

Fig.

Fig:1.14

**5. When the BM is above the Line of collimation:** This happens when the BM is at bottom of a bridge girder or on the bottom surface of a culvert. Suppose the BM exists on the bottom surface of a culvert and that is required to find out the RL of A. The level is set up at O and the staff is held inverted on the BM. The staff reading is taken and noted with a negative sign. The remark "staff held inverted" is to be entered in the appropriate column. Let the BS and FS readings be 1.500 and 2.250 respectively. Now,  $HI = 100.000 - 1.500 = 98.500$ ,  $RL \text{ of } A = 98.500 - 2.250 = 95.250$ .



Fig

Fig.1.14

**6. Levelling along a steep slope:** While leveling along a steep slope in a hilly area, it is very difficult to have equal BS and FS distances. In such cases the level should be set up along a Zig-zag path so that the BS and FS distances may be kept equal. Let AB be the direction of leveling.  $I_1, I_2, \dots$  are the positions of the level and  $S_1, S_2, S_3, \dots$  are the staff positions (Ref. Fig.). Levelling is continued in this manner and the RLs of the points are calculated.

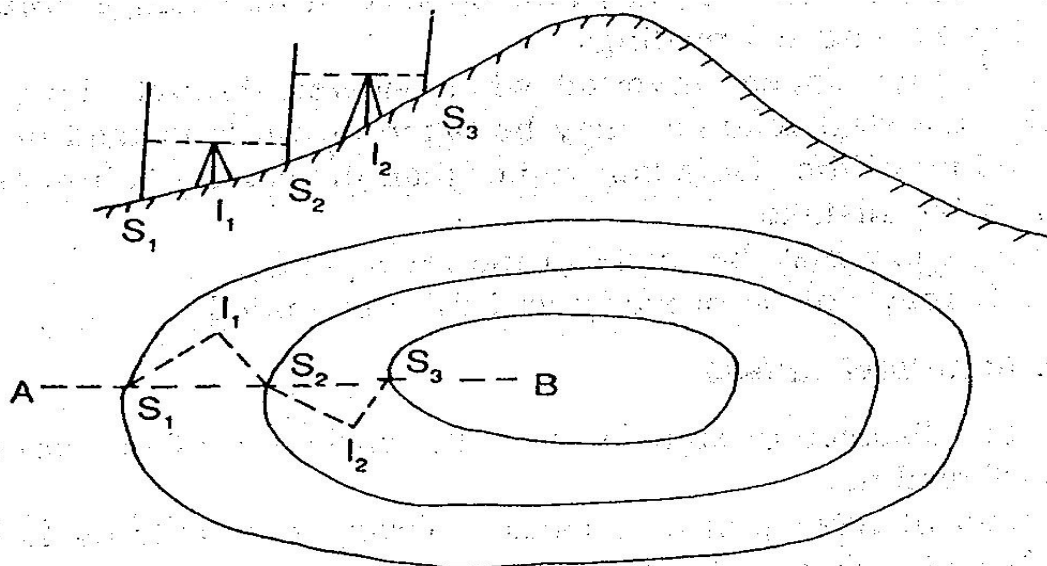

Fig.

Fig.1.14

**7. Levelling across arising ground or depression:** While levelling across high ground, the level should not be placed on top of this high ground, but on one side so that the line of collimation just passes through the apex. While leveling across a depression, the level should be set up on one side and not at the bottom of the depression. (Ref: Fig.)

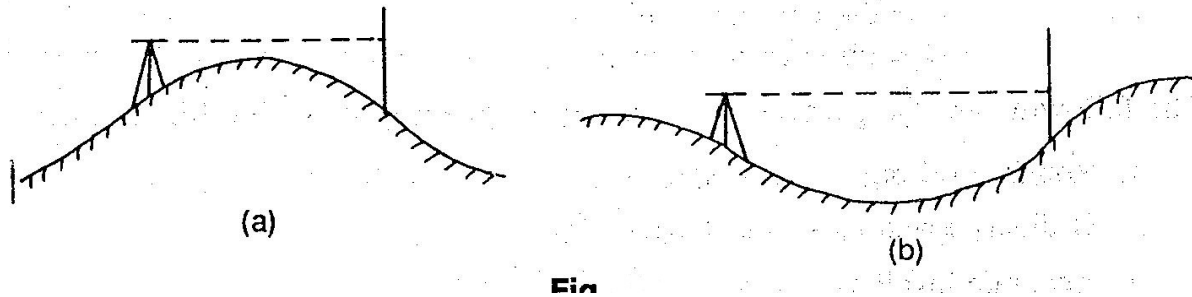

Fig:1.14

### Errors in levelling and precautions:

**1. Instrumental errors:** (a) The permanent adjustment of the instrument may not be perfect. That is the line of collimation may not be parallel to the axis of the bubble tube. (b) The internal arrangement of the focusing tube is not perfect. (c) The graduation of the leveling staff may not be perfect.

**2. Personal errors:** (a) The instrument may not be leveled perfectly. (b) The focusing of eye piece and object glass may not be perfect and the parallax may not be eliminated entirely. (c) The position of the staff may be displaced at the change point at the time of taking FS and BS readings. (d) The staff may appear inverted when viewed through the telescope. By mistake, the staff readings may be taken upwards instead of downwards. (e) The reading of the stadia hair rather than the central collimation hair may be taken by mistake. (f) A wrong entry may be made in the level book. (g) The staff may not be properly and fully extended.

**3. Errors due to natural Causes:** (a) When the distance of sight is too long, the curvature of the earth may effect the staff reading. (b) The effect of refraction may cause a wrong staff reading to be taken. (c) The effect of high winds and a shining Sun may result in a wrong staff reading.

### Permissible Errors in Levelling:

The precision of levelling is ascertained according to the error of closure. The permissible limit of closing error depends upon the nature of work for which the leveling is to be made. It is expressed as:  $E = C\sqrt{D}$ , Where,  $E$  = closing error in meter,  $C$  = the constant,  $D$  = distance in Km. The following are the permissible errors for different types of leveling:

1) Rough leveling- $E=\pm 0.100\sqrt{D}$ , (2) Ordinary leveling:  $-E=\pm 0.025\sqrt{D}$ , (3) Accurate Levelling:  $-E=\pm 0.012\sqrt{D}$ , (4) Precise Levelling:  $-E=\pm 0.006\sqrt{D}$

### 1.15 Sensitiveness of bubble tube, determination of sensitiveness:

The sensitivity of the level tube depends on the Radius of curvature ( R ) and usually expressed as  $\theta$  per unit division ( d ). This angle may vary from 1" to 2" in the case of precise level, up to 10" to 30" on engineer's level. This can be determined by in the field by observing the staff readings at a known distance from the level by changing the bubble position by means of a foot screw as shown in Fig.

$\tan n\theta = S/l$ , Since  $\theta$  is very small,  $\tan n\theta \approx n\theta$ ,  $n\theta_{rad} = S/l$ ,  $\theta_{rad} = S/nl$ ,  $\theta_{sec} = 206265 S/nl$ , Where S = diff. in staff reading a and b, n = no. of divisions the bubble is displaced between readings, l = distance of staff from instrument. If d = length of one division of the bubble tube then,  $d = R \theta_{rad}$ ,

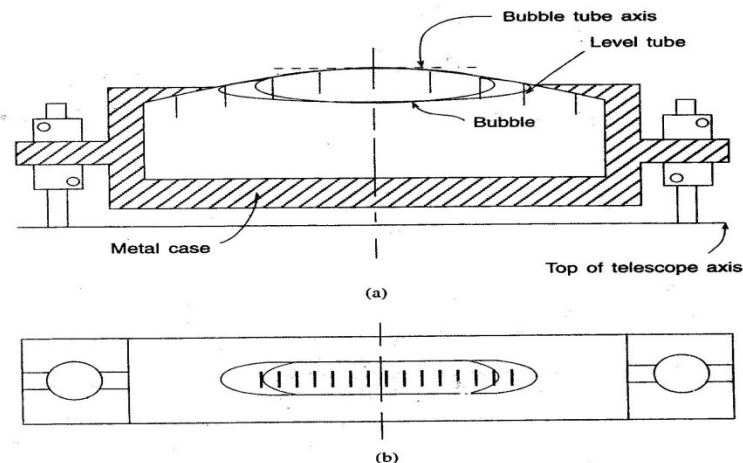

Fig. A bubble tube: (a) Cross section. (b) plan.

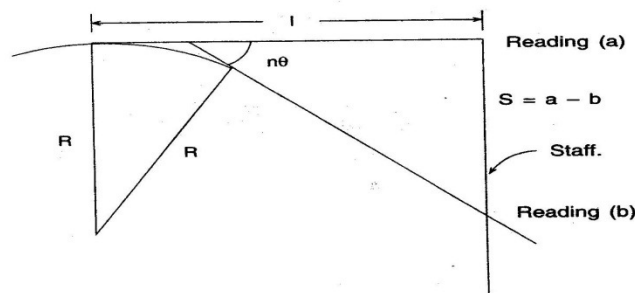

Fig. Sensitivity of bubble tube.

Fig:1.15

or  $R = d/\theta = ndl/S$ , A tube is said to be more sensitive, if the bubble moves by more divisions for a given change in the angle. The sensitivity of a bubble tube can be increased by:

a) Increasing internal radius of the tube, (b) Increasing diameter of the tube, (c) Increasing the length of the bubble, (d) decreasing the roughness of wall, (e) decreasing viscosity of the liquid. The

sensitivity of the bubble tube should tally with the accuracy achievable with other parts of the equipment. If the bubble is graduated from the centre than an accurate reading is possible by taking readings at the objective and eye piece ends (ref Fig.)

Let  $L$  = length of bubble =  $O_1 + E_1 = O_2 + E_2$ ,  $XX = \frac{(O_1 + E_1)}{2} - E_2$ ,  $YY = \frac{(O_2 + E_2)}{2} - O_2$ , Total movement =  $\frac{(O_1 - E_1)}{2} + \frac{(E_2 - O_2)}{2}$

Example: A three screw dumpy level, set up with the telescope parallel to two foot screws is sighted on a staff 100m away. The line of sight is depressed by manipulating the foot screws until the bubble on the telescope reads 4.1 at the object glass end and 14.4 at the eye piece end, these readings representing divisions from a zero at the centre of the bubble tube. The reading on the staff was 0.930m. By similarly elevating the sight the bubble readings were 12.6, 5.7 and staff reading 1.025m

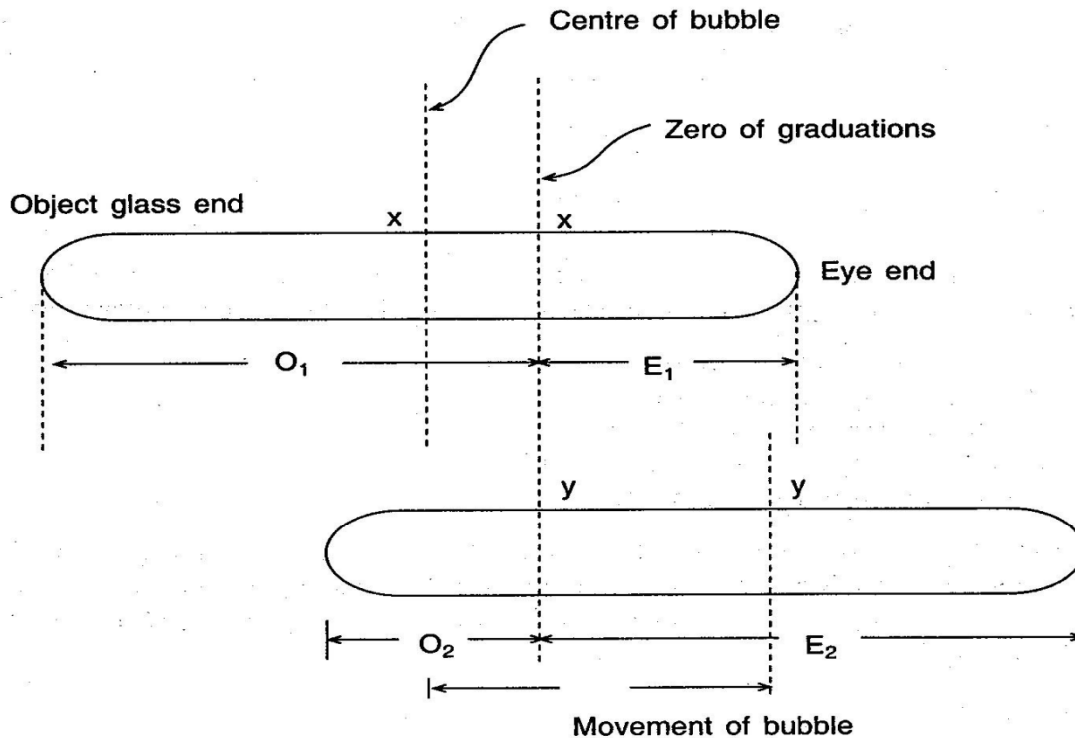

Fig.

Determine the sensitivity of the bubble and the radius of curvature of the bubble tube if the length of one division is 2.50 mm.

**Solution**

$$\begin{aligned}
 n &= \frac{O_1 - E_1}{2} + \frac{E_2 - O_2}{2} \\
 &= \frac{4.1 - 14.4}{2} + \frac{5.7 - 12.6}{2} \\
 &= - \frac{10.3 + 6.9}{2} = - \frac{17.2}{2} = - 8.6 \text{ divisions}
 \end{aligned}$$

(Negative because the line of sight is depressed and the bubble moves to the eyepiece end initially.)

$$\begin{aligned}
 \text{Sensitivity of bubble } \theta_{\text{sec}} &= \frac{206265S}{nl} \\
 &= \frac{206265(1.025 - 0.930)}{8.6(100)} \\
 &= 22.78''
 \end{aligned}$$

### 1.16 Permanent adjustment of different types of levels:

The establishment of desired relationship between fundamental lines of a levelling instrument is termed as permanent adjustment. So, permanent adjustment indicates the rectification of instrumental errors.

The fundamental lines are as follows:

1. The line of collimation, (2) The axis of the bubble tube, (3) The vertical axis, (4) The axis of telescope.

The relationships between the lines are as follows:-

1. The line of collimation should be parallel to the axis of bubble tube, (2) The line of collimation should coincide with the telescope, (3) The axis of the bubble should be perpendicular to the vertical axis. i.e., the bubble should remain in the central position for all directions of the telescope.

Principle of reversal: If there is any error in a certain part of the instrument, then it will be doubled by reversing, i.e. by revolving the telescope through  $180^\circ$ . Thus the apparent error becomes twice the actual error on reversal. In a right angled triangle ABC, the angle ACB is not exactly  $90^\circ$  but less by  $\theta$ . If this triangle is reversed as  $A_1B_1C$ , then the angle between the faces BC and  $B_1C$  becomes  $2\theta$ . This is the principle of reversal. By this principle, the relationship between the fundamental lines can be determined and hence necessary correction can be applied.

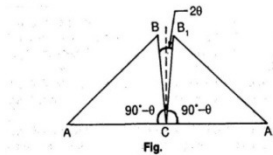

Fig:1.16

Permanent adjustment of dumpy level: (1) To make the axis of the bubble tube perpendicular to the vertical axis.

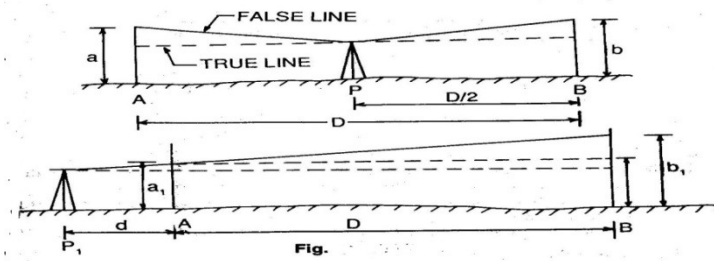

Fig:1.16

a)The level is set up on fairly level and firm ground,with its legs well apart.it is firmly fixed to the ground.(b)The telescope is placed parallel to any pair of foot screws and by turning the foot screws either both inward or both outward,the bubble is brought to the centre.(c)The telescope is the turned through  $90^\circ$ ,so that it lies over the third foot screw.Then by turning the third foot screw the bubble is brought to the centre,(d)The process is repeated several times until the bubble is in central position in both the directions,(e)Now the telescope is turned through  $180^\circ$  and the position of the bubble is noted.If the bubble still remains in the central position,the desired relationship is perfect.If not,the amount of deviation of the bubble is noted.,(f)suppose the deviation is  $2n$  divisions.Now by turning the capstan headed nut(which is at one end of the tube),the bubble is brought half-way back(i.e  $n$  division).The remaining half division is adjusted by the foot screw or screw just below the telescope.(g)The procedure of adjustment is continued till the bubble remains central position of the telescope.

(2)Two peg method(1)Two pegs A and B are driven at a known distance apart(Say  $D$ )on level and firm ground.The level is set up at P,just mid way between A and B.After bringing the bubble to the centre of its run(usual),the staff readings on A and B are taken.the staff readings are  $a$  and  $b$ .Now the difference of level between A and B is calculated, this difference is the true difference, as the level is set up just mid-way between BS and FS.Then the rise or fall is determined by comparing the staff readings.(b)The level is shifted and set up at  $P_1$ (very near to A),say at a distance  $d$  from A.Then after proper leveling(following usual method),staff readings at A and B are taken.Suppose the readings are  $a_1$  and  $b_1$ .Then the apparent difference of level is calculated.(c)If the true difference and apparent difference are equal,the line of collimation is in adjustment.If not, the line of collimation is inclined.,(d)In the second set up,let  $e$  be the staff reading on B at the same level of the staff reading  $a_1$ . Then  $e = a_1 \pm$  true difference(use the positive sign in case of a fall and negative sign in case of Rise)

(e)If  $b_1$  is greater than  $e$ , the line of collimation is inclined upwards and if  $b_1$  is less than  $e$ ,it is inclined downwards.Collimation errors= $b_1 - e$ (in a distance  $D$ )(f) By applying the principle of similar triangle,Correction to near peg, $C_1 = \frac{d}{D} (b_1 - e)$ ,correction to far peg, $C_2 = \frac{D + d}{D} (b_1 - e)$ ,Correct staff reading on A =  $a_1 \pm C_1$ ,correct staff reading on B =  $b_1 \pm C_2$  (use the positive sign when the line of collimation is inclined downwards,and the negative sign when it is inclined upwards)(g)Then the cross hair is brought to the calculated correct reading by raising or lowering the diaphragm by means of the diaphragm screw.

Field procedures:(1)If the correct reading is seen below the collimation hair on looking through the telescope, the cross hair is to be lowered. This is done by loosening the upper screw and tightening the lower screw of the diaphragm.(2)If the correct reading is seen above the collimation hair, on looking through the telescope,the cross hair should be raised. This is done by loosening the lower screw and tightening the upper screw of the diaphragm.



### 1.17 Setting grades and stakes:

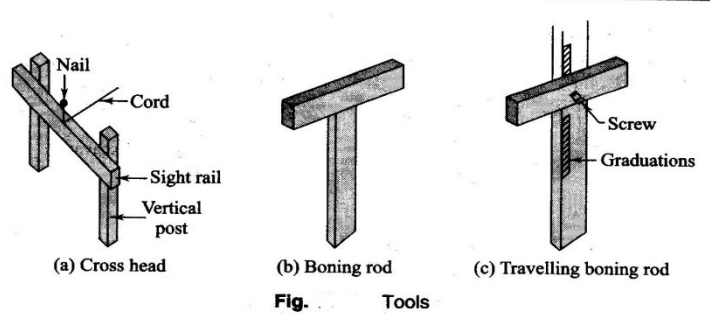

Fig:1.17

Setting out of sewer Lines: Underground pipelines and sewer pipes have to be laid to a particular gradient designed for the ease of flow of water or sewage. The inside bottom of the sewer pipe is known as invert. Some special tools are required to set the line gradient.

**Cross head:** It consists of two posts and a horizontal bar. The posts are of suitable heavy cross section and the horizontal member, known as the sight rail, has an area of 50mmX150mm. Cross heads are kept at the top and bottom of the gradient. The top of the sight rail is kept at a convenient height, 2-5m.

**Boning rod:** It resembles a cross. A vertical wooden piece measuring 100mm long, and is plotted at a convenient height depending upon the setting of the sight rail. The top of the boning rod is a reference for determining the depth of excavation in a section. One boning rod is required for a particular gradient. Different boning rods are required for different gradients.

**Travelling Rod:** It is an adjustable boning rod. The horizontal piece can be moved over the vertical piece thus varying the height of the rod.

#### Setting out:

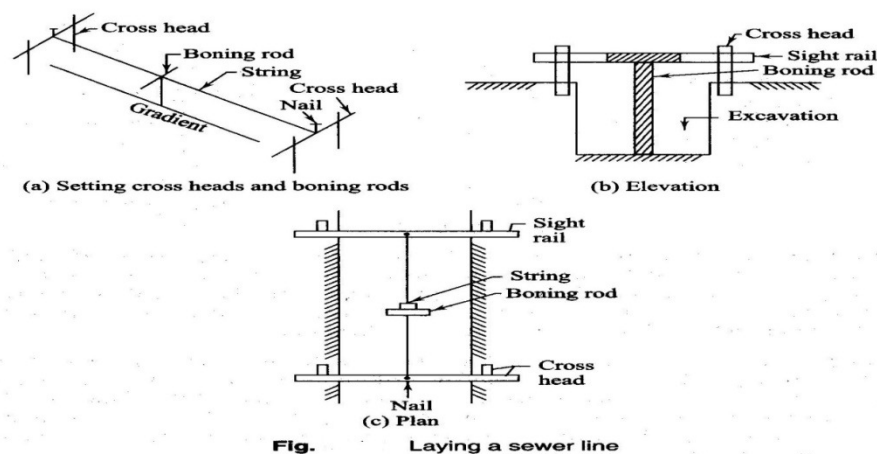

Fig:1.17

To set out the sewer on the gradient, the following procedure is adopted.

- 1) Set the alignment of the line on the surface with reference to the control points brought near the site. Also establish the vertical control points for setting out the grade.
- 2) Lay a line parallel to the alignment for reference, as the first line will be lost once the excavation starts.
- 3) Start work from the lower point. Place the sight rails at the bottom and top of the gradient line. Drive nails at the centre of the cross piece of the cross heads. Stretch a string between the nails to act as a reference for vertical distances.
- 4) Drive the cross heads in such a way that the top of the sight rail is 2-5m above the invert of the sewer. This may be done with a level and take the readings. The boning rod is used of same length as the setting of the sight rail in the gradient section.
- 5) The string stretched between the nails on the sight rails should have the same gradient as that of the sewer line.
- 6) Check the proper depth of the excavation at any intermediate point using the boning rod.

## CHAPTER-2

### CONTOURING:

2.1 Definitions of related terms, concepts of contours, characteristics of contours:

1) Contour line: The line of intersection of a level surface with the ground surface is known as the contour line or simply the contour. It can also be defined as a line passing through points of equal reduced levels.

**1) Contour line:** The line of intersection of a level surface with the ground surface is known as the contour line or simply the contour. It can also be defined as a line passing through points of equal reduced levels.

For example, a contour of 100 indicates that all the points on this line have an RL of 100 m.

Similarly, in a contour of 99 m, all the points have an RL of 99 m, and so on (Fig.). A map showing only the contour lines of an area is called a contour map.

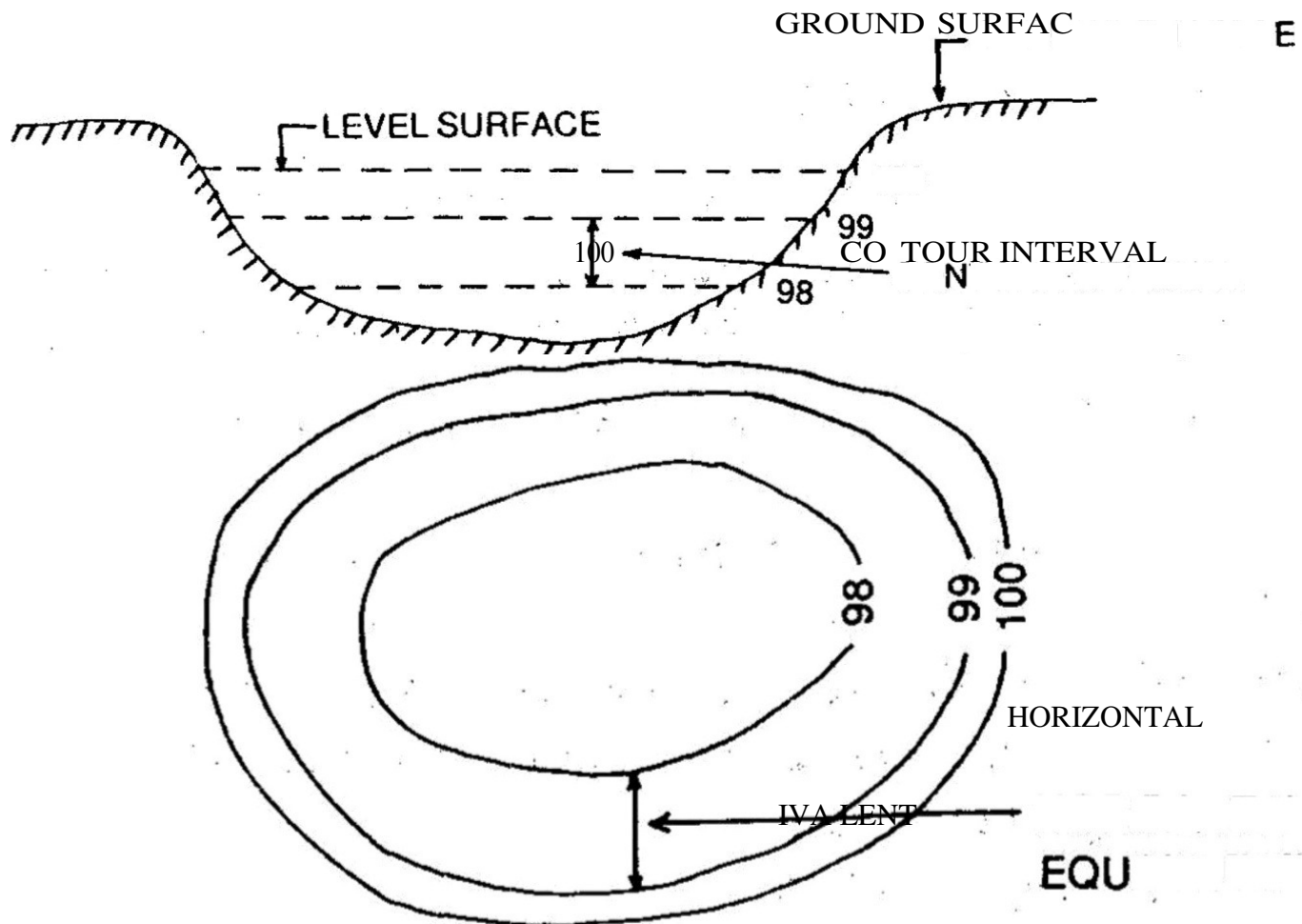

Fig.2.1

**2. Contour Interval:** The vertical distance between any two consecutive contours is known as a contour interval. Suppose a map includes contour lines of 100 m, 98 m, 96 m, and so on. The contour interval here is 2 m. This interval depends upon: (i) the nature of the ground (i.e. whether flat or steep), (ii) the scale of the map, and (iii) the purpose of the survey.

Contour intervals for flat country are generally small, e.g. 0.25 m, 0.50 m, 0.75 m, etc. The contour interval for a steep slope in a hilly area is generally greater, e.g. 5 m, 10 m, 15 m, etc.

Again for a small-scale map, the interval may be of 1 m, 2 m, 3 m, etc. and for Large scale map it may be of 0.25 m, 0.50 m, 0.75 m etc. It should be remembered that the contour interval for a particular map is constant. The horizontal distance between any two consecutive contours is known as horizontal equivalent. It is not constant. It varies according to the steepness of the ground. For steep slopes, the contour lines run closer together, and for flatter slopes they are widely spread.

## 2.1: Methods of contouring, plotting contour maps

### OBJECT OF PREPARING CONTOUR MAP:

The general map of a country includes the locations of roads, railways, rivers, Villages, towns, and so on. But the nature of the ground surface cannot be realised, from such a map. However, for all engineering projects involving roads, railways, and so on, a knowledge of the nature of the ground surface is required for locating suitable alignments and estimating the volume of earth work. Therefore, the contour map is essential for all engineering project. This is why contour maps are prepared.

### USES OF CONTOUR MAP:

The following are the specific uses of the contour map:

The nature of the ground surface of a country can be understood by studying a contour map. Hence, the possible route of communication between different places can be demarcated.

A suitable site or an economical alignment can be selected for any engineering project. The capacity of a reservoir or the area of a catchment can be approximately computed.

The intervisibility or otherwise of different points can be established. A suitable route for a given gradient can be marked on the map.

A section of the ground surface can be drawn in any direction from the contour map. Quantities of earth work can be approximately computed.

**Characteristics of Contours:** 1. (Ref Fig. ) the contour lines are closer near the top of a hill or high ground and wide apart near the foot. This indicates a very steep slope towards the peak and a flatter slope towards the foot.

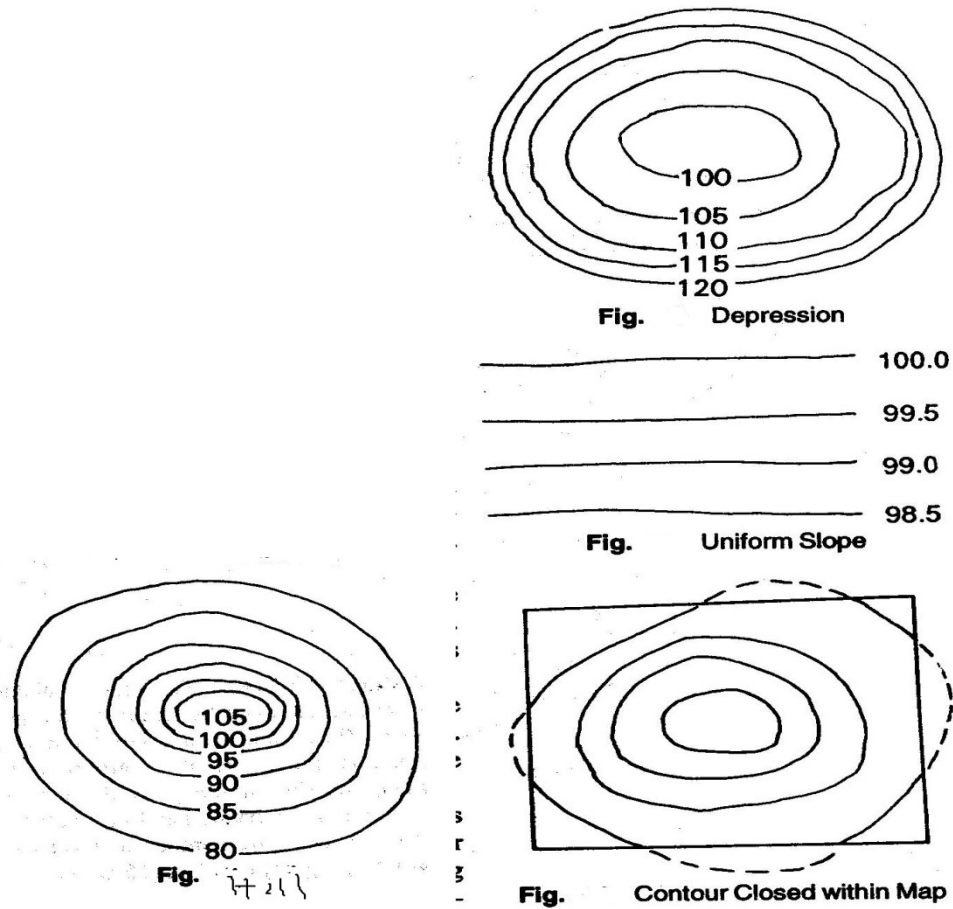

Fig:2.1

2. In Fig. the contour lines are closer near the bank of a pond or depression and wide apart towards the centre. This indicates a steep slope near the bank and a flatter slope at the centre.

3. Uniformly spaced, contour lines indicate a uniform slope (Fig. ).

4. Contour lines always form a closed circuit. But these may be within or outside the limits of the map (Fig. ).

5. Contour lines cannot cross one another, except in the case of an overhanging cliff. But the over-lapping portion must be shown by a dotted line (Fig. ).

6. When the higher values are inside the loop, it indicates a ridge line. Contour lines cross ridge lines at right angles (Fig. ).

7. When the lower values are inside the loop, it indicates a valley line. Contour lines cross the valley line at right angles (Fig. ).

8. A series of closed contours always indicates a depression or summit. The lower values being inside the loop indicates a depression and the higher values being inside the loop indicates a summit. (Fig. ).

9. Depressions between summits are called saddles (Fig.)

10. Contour lines meeting at a point indicate a vertical cliff.

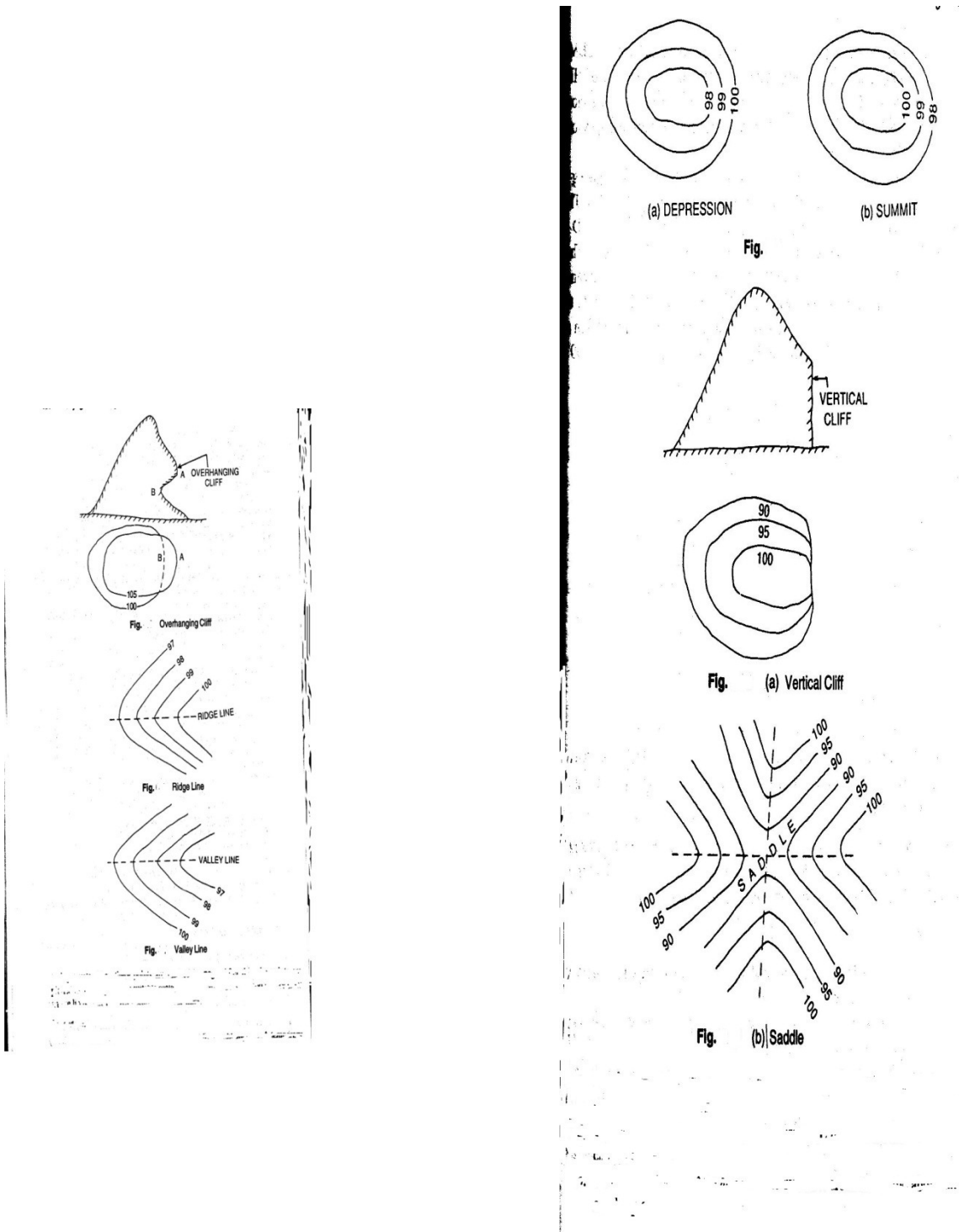

Fig:2.1

METHODS OF CONTOURING

There are two methods of contouring----direct and indirect.

A) Direct Method:

There may be two cases, as outlined below.

**Case-I:** When the area is oblong and cannot be controlled from a single station: In this method, the various points on any contour are located on the ground by taking levels. Then these points are marked by pegs. After this, the points are plotted on the map to any suitable scale, by plane table. This method is very slow and tedious. But it gives accurate contour lines.

**Procedure:** 1) Suppose a contour map is to be prepared for an oblong area. A temporary Bench mark is set up near the site by taking fly level readings from a permanent bench mark. (2) The level is then set up at a suitable position L from where maximum area can be covered. (3) The Plane table is set up at a suitable station P from where the above area can be plotted. (4) A back sight reading is taken on the TBM. Suppose the RL of the TBM is 249.500 m and that the BS reading is 2.250 m. then the RL of HI is 251.750 m. If a contour of 250.000 is required, the staff reading should be 1.750 m. If a contour of 249.000 m is required, the staff reading should be 2.750 m, and so on. (5) The staff man holds the staff at different points of the area by moving up and down, or left and right, until the staff reading is exactly 1.750. Then, the points are marked by pegs. Suppose, these points are A, B, C, D,....

6) A suitable point p is selected on the sheet to represent the station P. With the alidade touching p, rays are drawn to A, B, C and D. The distances PA, PB, PC and PD are measured and plotted to a suitable scale. In this manner, the points a, b, c and d of the contour line of RL 250.000 m are obtained. These points are joined to obtain the contour of 250.000 m

7) Similarly, the points of the other contours are fixated. (8) When required, the levelling instrument and the plane table are shifted and set up in a new position in order to continue the operation along the oblong area.



**Case-II:**When the area is small and can be controlled from a single station: In this case, the method of radial lines is adopted to obtain contour map. This is also very slow and tedious, but gives the actual contour lines.

**Direct Method:**

1)The plane table is set up at a suitable station P from where the whole area can be commanded.

2)A point p is suitably selected on the sheet to represent the station P. Radial lines are then drawn in different directions.

3) A temporary bench-mark is established near the site. The level is set up at a suitable position L and a BS reading is taken on the TBM. Let the HI in this setting be 153.250 m. So, to Find the contour of RL, 152.000 in a staff reading of 1.250 in is required at a particular point, so that the RL of contour of that point comes to 152.000 m.

$$\begin{aligned} \text{RL} &= \text{HI} - \text{Staff reading} \\ &= 153.250 - 1.250 = 152.000 \text{ in} \end{aligned}$$

4.The staff man holds the staff along the rays drawn from the plane table station in such a way that the staff reading on that point is exactly 1.25. In this manner, points A, B, C, D and E are located on the ground, where the staff readings are exactly 1.250.(5)The distances PA, PB, PC, PD and PE are measured and plotted to any suitable scale. Thus the points a, b, c, d and e are obtained which are joined in order to obtain a contour of 152.000.(6)The other contours may be located in similar fashion (Fig. ).

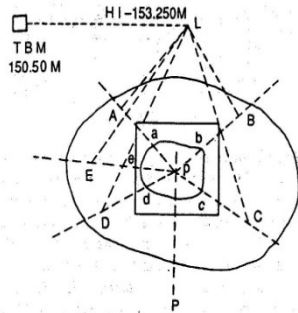

Fig.

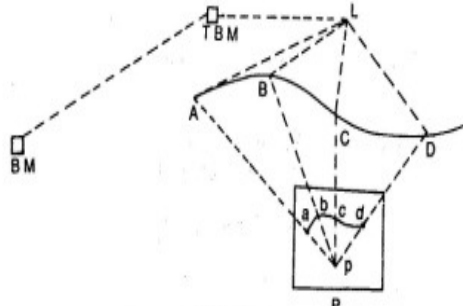

Fig.

Fig:2.2

**Indirect Method:** In this method, the RLs of different points (spot levels) are taken at regular intervals along a series of lines set up on the ground. The positions of these points are plotted on a sheet to any suitable scale. The spot levels are noted at the respective points. Then the points of contour lines are found out by interpolation, after which they are joined to get the required contour lines. Although very quick, this method gives only the approximate positions of the contour lines. This method can be adopted in two ways, (i) cross-sections, and (ii) squares.

**(a)Using Cross-sections:** In this method, a base line, centre line or profile line is considered. Cross-sections are taken perpendicular to this line at regular intervals (say 50 m, 100m etc.). After this, points are marked along the cross-sections at regular intervals (say, 5m, 10m, etc). A temporary bench-mark is set up near the site. Staff readings are taken along the base line and the cross-sections. The readings are entered in the level book; the base line and the cross-sections should also be mentioned. The RL of each of the points calculated. Then the base line and cross-sections are plotted to a suitable scale. Subsequently the RLs of the respective points are noted on the map, after which the required contour line is drawn by interpolation. This method is suitable for route survey, when the cross sections are taken transverse to the longitudinal section.

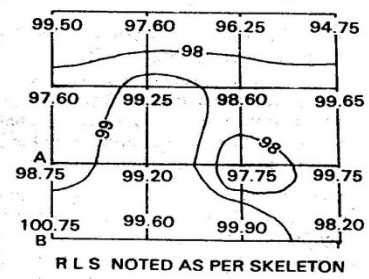
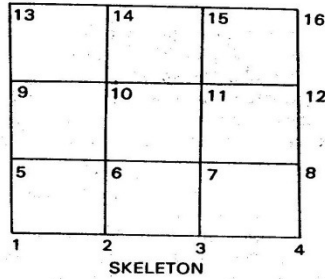
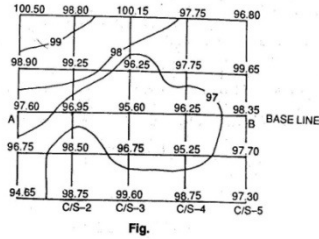

Fig:2.2

**(b)Using Squares:** In this method, the area is divided into a number of squares. The size of these squares depends upon the nature and extent of the ground. Generally they have a sides varying from 5 to 20m. The corners of the squares are numbered serially, as 1,2,3,.....A temporary bench mark is set up near the site, and the level is set up at a suitable position. The staff readings on the corners of the squares are taken and noted in the level book maintaining the sequence of the serial numbers of the corners. The RLs of all the corners are calculated. The skeletons of the squares are plotted to a suitable scale. The respective RLs on the corners, after which the contour lines are drawn by interpolation.

### 2.3 Interpretation of contour maps, toposheets:

**Method of Interpolation of Contours:** The process of locating the contours proportionately between the plotted points is termed interpolation. This can be done by:

(1) **Arithmetical Calculation:** Let A and B be two corners of the squares. The RL of A is 98.75m, and that of B 100.75m. The horizontal distance between A and B is 10m, Horizontal distance between A and B = 10m, Vertical distance between A and B = 100.75 - 98.75 = 2m, Let a contour of 99.00m be required. Then, difference of level between A and 99.00m contour = 99.00 - 98.75 = 0.25m, ∴ Distance of 99.00m contour line from A =  $\frac{10}{2} \times 0.25 = 1.25$ m. This calculated distance is plotted to the same scale in which the skeleton was plotted, to obtain a point of RL of 99.00m, Similarly the other point is located.

(2) **By graphical method:** On a sheet of tracing paper, a line AB is drawn and divided into equal parts. AB is bisected at C, and a perpendicular is drawn at this point. A point O is selected on this perpendicular. Then radial lines are drawn from O to the divisions on AB. These lines serve as guide

lines. The boundary line and every fifth line is marked with a thick or red line. Suppose we have to interpolate a 2m contour interval between two points a and b of RLs 92.5 and 100.75m. Let us consider the lowest radial line OB to represent an RL of 90.00. So every fifth line (which is bold red or red) will represent 95.100, 105, etc. The tracing paper is moved over the plan until a lies at 92.5 and b at 100.25. Line ab should be parallel to AB. Now the points 94, 96, 98, 100 are picked through to obtain the positions of the required contour.

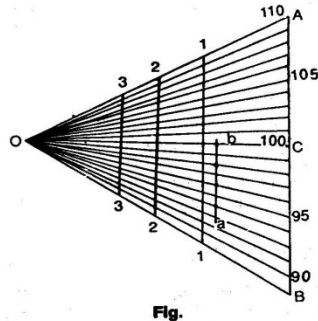

Fig:2.3

2.4 Use of contour maps on civil engineering projects-drawing cross-sections from contour maps, locating:

Since a contour map is a three dimensional representation of the earth's surface. it furnishes a lot of information. Some of the uses that a contour map can be put to are as follows.

**Determination of intervisibility:** Let it be required to ascertain the intervisibility of two stations A and B having elevations 62m and 90m, respectively, as shown in the contour map (Ref: fig.). Join A and B is 28m ( $90-62=28$ ). The line of sight will have an inclination of 28m in the distance ab. draw projections to mark points of elevation of 90, 85, ..., 62 on the line ab. Compare these points with the corresponding points in which the contours cut the line ab. At the point e, the ground has an elevation of 75 and 70m, whereas line of sight will have an elevation less than 75m (between 75 and 70m). It can be seen that there will be obstruction in the range CD. Similarly, checks can be made for the other points.

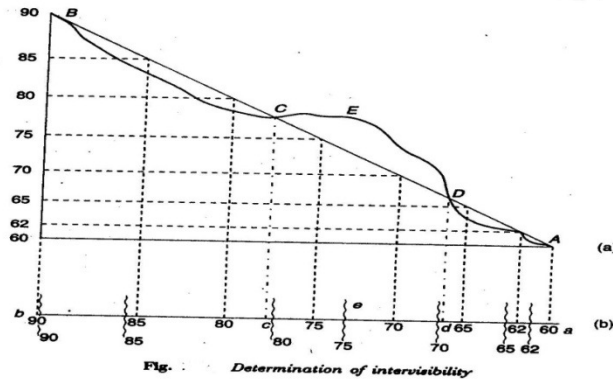

Fig:2.4

**Drainage area:**The extent of drainage area may be estimated on a contour map by locating the ridge line around the watershed.The ridge line should be located in such apposition that the ground slopes are down on either side of it.The area is found out by Planimetric measurements.

**Capacity of reservoirs:**Reservoirs are made for water supply and for power or irrigation projects.A contour map is very useful to study the possible location of a dam and the volume of water to be confined.All the contours are closed lines within the reservoir area.

**Site of structures:**The most economical and suitable site for structures such as buildings,bridges,dams etc. can be found from large –scale contour maps.

**Earthquake estimates:**On the contour line of the original surface,the contours of the desired altered surface are drawn.By joining the intersections of the original contours and new ones of equal value,the line in which the new surface cuts the original is obtained.Exacavation is required within this line,whereas the surrounding parts will be in the embankment.The volume of cut or a fill is found by multiplying the average by the contour interval.

**Route Location:**By inspecting a contour map the most sitable site for a road,railway,canal etc. can be selected.By following the contour lines,steep gradients,cutting and filling,etc.may be avoided.

## CHAPTER-3

### INTRODUCTION

An instrument used for measuring horizontal and vertical angles accurately, is known as a theodolite. Theodolite is also used for prolongation or survey line, finding difference in elevation and setting out engineering work requiring higher precision i.e. ranging the highway and railway curves, aligning tunnels, etc.

### PARTS OF A TRANSIT THEODOLITE: -

A transit theodolite consists of the following essential parts:

- 1) **Leveling head:** - It consists of two parts i.e. upper tribarch and lower tribarch.
  - (i) **The upper tribarch:** - It has three arms. Each arm carries a leveling screw. Leveling screws are provided for supporting leveling the instrument. The boss of the upper tribarch is pierced with a female axis in which lower male vertical axis operates.
  - (ii) **The lower tribarch:** - It has a circular hole through which a plumb bob may be suspended for centering the instrument quickly and accurately.

The three distinct functions of a leveling head are:

- (i) To support the main part of the instrument.
  - (ii) To attach the theodolite to the tripod.
  - (iii) To provide a means for leveling the theodolite.
- 2) **Lower plates (or scale plate).** The lower plate which is attached to the outer spindle carries a horizontal graduated circle at its beveled edge. It is therefore sometimes known as the scale plate. It is divided into  $360^\circ$ . Each degree is further divided into ten minutes or twenty minutes arc intervals. Scale plate can be clamped at any position by clamping screw and a corresponding slow motion can be made with a tangential screw or slow motion screw. When the lower clamp is tightened, the lower plate is fixed to the upper tribarch of the leveling head. The size of the theodolite is determined by the size of the diameter of the lower plate.
- 3) **Upper plate (or vernier plate):** - The upper plate or vernier plate is attached to the inner spindle axis. Two verniers are screwed to the upper plate diametrically opposite. This plate is so constructed that it overlaps and protects the lower plate containing the horizontal circle completely except at the parts exposed just below the verniers. The verniers are fitted with magnifiers. The upper plate supports the Ys or As which provide the bearings to the pivots of the telescope. It carries an upper clamp screw and a corresponding tangent screw for accurately fixing to the lower plate on clamping the upper clamp and unclamping the lower clamp, the instrument may be rotate on this outer spindle without any relative motion between two plates. On the other hand if the lower clamp screw is tightened and upper clamp screw is unclamped, the instrument may be rotate about the inner spindle with a relative

motion between the vernier and the graduated scale of the lower plate. This property is utilized for measuring the angle between two settings of the instrument. It may be ensured that the clamping screws are properly tightened before using the tangent screws for a finer setting.

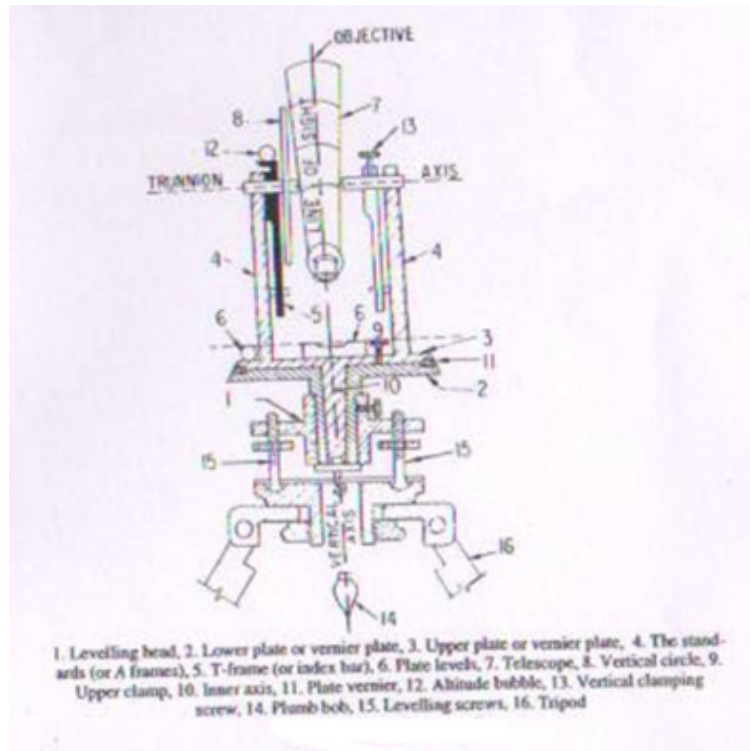

Fig.3.1 Shows parts of transit theodolite

- 4) **The standards (or A frame):** - Two standards resembling the English letter A are firmly attached to the upper plate. The tops of these standards form the bearing of the pivots of the telescope. The standards are made sufficiently high to allow the rotation of the telescope on its horizontal axis in vertical plane. The T-frame and the arm of vertical circle clamp are also attached to the standards.
- 5) **T-frame or index bar:-** It is T-shaped and is centered on the horizontal axis of the telescope in the frame of the vertical circle. The two verniers C and D are provided on it at the ends of the horizontal arms, called the index arm. A vertical leg known as clipping arm is provided with a fork and two clipping screw at its lower extremity. The index and clipping arms together are known as T-frame. At the top of this frame, if attached a bubble tube which is called the altitude bubble tube.
- 6) **Plate levels:** - The upper plate carries two plate levels placed at right angles to each other. One of the plate bubbles is kept parallel to the trunnion axis. The plate levels can be centered with the help of the foot screws. In some theodolites only one plate level is provided.
- 7) **Telescope:** - The telescopes may be classified as
  - (i) The external focusing telescope

- (ii) The internal focusing telescope.

## DEFINITIONS AND OTHER TECHNICAL TERMS

Following terms are used while making observations with a theodolite.

1. **Vertical axis:-** The axis about which the theodolite, may be rotated in a horizontal plane, is called vertical axis. Both upper and lower plates may be rotated about vertical axis.
2. **Horizontal axis:-** The axis about which the telescope along with the vertical circle of a theodolite, may be rotated in vertical plane, is called horizontal axis. It is also sometimes called trunnion axis or traverse axis.
3. **Line of collimation:-** The line which passes through the intersection of the cross hair of the eye piece and optical center of the objective and its continuation is called line of collimation. The angle between the line of collimation and the line perpendicular to the horizontal axis is called error of collimation.

The line passing through the eye piece and any point on the objective is called line of sight.

4. **Axis of telescope:-** The axis about which the telescope may be rotated is called axis of telescope.
5. **Axis of the level tube:-** The straight line which is tangential to longitudinal curve of the level tube at its center is called the axis of the level tube. When the bubble of the level tube is central, the axis of the level tube becomes horizontal.

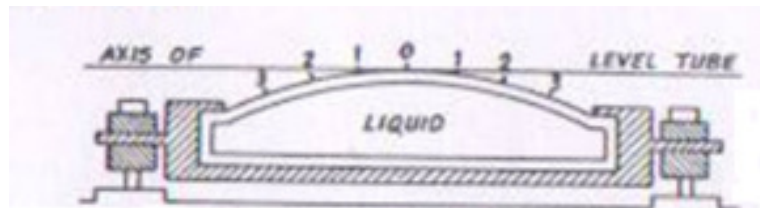

Fig.3.2 Cross section of level tube

6. **Centering:-** The process of setting up a theodolite exactly over the ground station mark, is known as centering. It is achieved when the vertical axis of the theodolite is made to pass through the ground station mark.
7. **Transiting:-** The process of turning the telescope in vertical plane through  $180^\circ$  about its horizontal axis is known as transiting. The process is also sometimes known as reversing or plunging.
8. **Swing:-** A continuous motion of the telescope about the vertical axis in horizontal plane is called swing. The swing may be in either direction i.e. left or right. When the telescope is rotated in the clockwise right direction, it is known as right swing. If it is rotated in the anticlockwise left direction it is known as left swing.



9. **Face left observations:** - When the vertical circle is on the left. of the telescope at the time of observations, the observations of the angles are known as face left observations.
10. **Face right observations:** - When the vertical circle is on the right of the telescope at the time of observations, the observations of the angles are known as face right observations.
11. **Changing face:-** It is the operation of changing the face of the telescope from left tom right and vice-versa.
12. **Telescope normal:** - Telescope is said to be normal when its vertical circle is to its left and the bubble of the telescope is up.
13. **Telescope inverted:** - A telescope is said to be inverted or reversed when its vertical circle is to its right and the bubble of the telescope is down.

### FUNDAMENTAL LINES OF A TRANSIT THEODOLITE

The fundamental lines of a transit theodolite are:

- 1) The vertical axis
- 2) The axis of plate bubble
- 3) The line of collimation which is also sometimes called line of sight.
- 4) The horizontal axis, transverse axis or trunnion axis.
- 5) The bubble line of telescope bubble or altitude bubble.

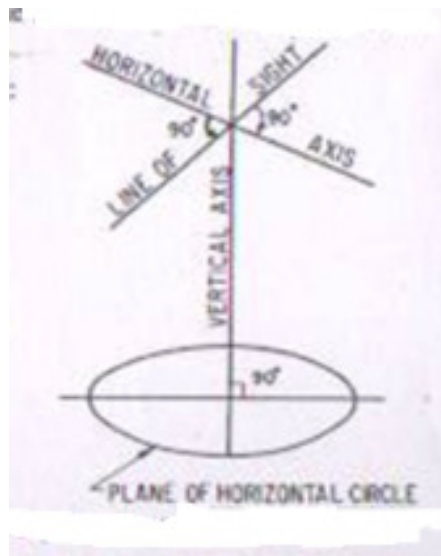

Fig.3.3 Fundamental lines of transit theodolite

### ADJUSTMENTS OF THEODOLITE

The adjustments of theodolites are of two kinds.

1. Temporary adjustment
2. Permanent adjustment

**Temporary adjustments:** The adjustments which are required to be made at every instrument station before making observations are known as temporary adjustments.

The temporary adjustments of a theodolite include the following:

- i. Setting up the theodolite over the station.
- ii. Leveling of the theodolite
- iii. Elimination of the parallax.
  - 1) **Setting up:** - The operation of setting up a theodolite includes the centering of the theodolite over the ground mark and also approximate leveling with the help of tripod legs.
  - 2) **Centering:** - The operation with which vertical axis of the theodolite represented by a plumb line, is made to pass through the ground station mark is called centering.

The operation of centering is carried out in following steps:

- i. Suspend the plumb bob with a string attached to the hook fitted to the bottom of the instrument to define the vertical axis.
- ii. Place the theodolite over the station mark by spreading the legs well apart so that telescope is at a convenient height.
- iii. The centering may be done by moving the legs radially and circumferentially till the plumb bob hangs within 1cm horizontally of the station mark.
- iv. By unclamping the center shifting arrangement, the finer centering may now be made.

#### **Approximate leveling with the help of the tripod:**

It is very necessary to ensure that the level of the tripod head is approximately level before centering is done. In case there is a considerable dislevelment, the centering will be disturbed when leveling is done. The approximate levelling may be done either with reference to a small circular bubble provided on the tribarch or by eye judgment.

**Levelling of a theodolite:** The operation of the making the vertical axis of a theodolite truly vertical is known as leveling of the theodolite.

After having leveled approximately and centered accurately, accurate leveling is done with the help of plate levels. Two methods of leveling are adopted to the theodolites, depending upon the number of leveling screws.

**Levelling with three screw head:** - The following steps are involved

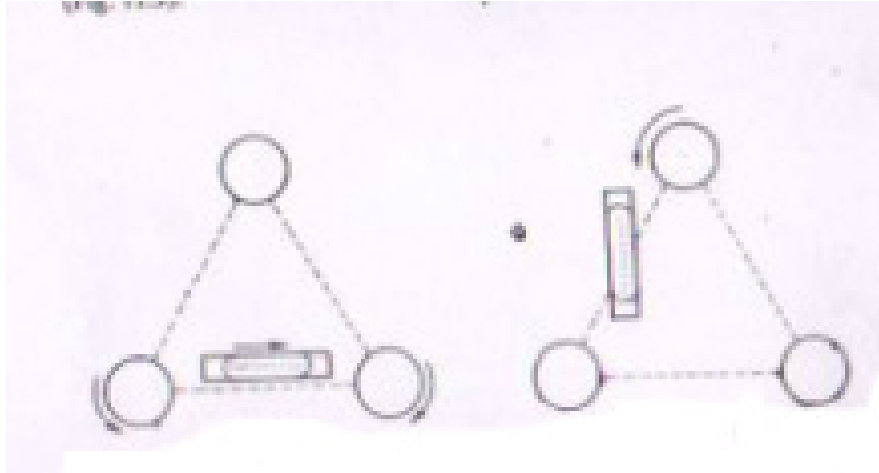

Fig.3.4 Leveling of a theodolite with a three screw head

- 1) Turn the horizontal plate until the longitudinal axis of the plate level is approximately parallel to line joining any two leveling screws [fig (a)].
- 2) Bring the bubble to the center of its run by turning both foot screws simultaneously in opposite directions either inwards or outwards. The movement of the left thumb indicates the direction of movement of the bubble.
- 3) Turn the instrument through  $180^\circ$  in azimuth.
- 4) Note the position of the bubble. If it occupies a different position, move it by means of the same foot screws to the approximate mean of the two positions.
- 5) Turn the theodolite through  $90^\circ$  in a azimuth so that the plate level becomes perpendicular to the previous position [fig. (b)].
- 6) With the help of the third foot screw move the bubble to the approximate mean position already indicated.
- 7) Repeat the process until the bubble retains the same position for every setting of the instrument in azimuth.

The mean position of the bubble is called the zero of the level tube. If the theodolite is provided with two plate levels placed perpendicular to each other, the instrument is not required to be turned through  $90^\circ$ . In this case, the longer plate level is kept parallel to any two foot screws and the bubble is brought to central position by turning both the foot screws simultaneously. Now with the help of the third foot screw, bring the bubble of second plate level central. Repeat the process till both the plate bubbles occupy the central position of their run for all the positions of the instrument.

**ELEMENTATION OF PARALLAX:** - An apparent change in the position of the object caused by change in position of the surveyor's eye is known as parallax.

In a telescope parallax is caused when the image formed by the objective is not situated in the plane of the cross hairs. Unless parallax is removed accurate bisections and sighting of objects become difficult.

Elimination of parallax may be done by focusing the eye piece for distinct vision of cross hairs and focusing the objective to bring the image of the object in the plane of the cross-hairs as discussed below.

**Focusing the eye piece:** To focus the eye-piece for distinct vision of cross hairs, either holds a white paper in front of the objective or sight the telescope towards the sky. Move the eye piece in or out till the cross hairs are seen sharp and distinct.

**Focusing the objective:** After cross hairs have been properly focused, direct the telescope on a well defined distant object and intersect it with vertical wire. Focus the objective till a sharp image is seen. Removal of the parallax may be checked by moving the eye slowly to one side. If the object still appears intersected, there is no parallax.

If, on moving the eye laterally, the image of the object appears to move in the same direction as the eye, the observer's eye and the image of the object are on the opposite sides of the vertical wire. The image of the object and the eye are brought nearer to eliminate the parallax. This parallax is called far parallax.

If, on the other hand, the image appears to move in reverse direction to the movement of the eye, the observer's eye and the image of the object are on the same side of the vertical wire and the parallax is then called near parallax. It may be removed by increasing the distance between the image and the eye.

### **MISCELLANEOUS USES OF THEODOLITE:**

Theodolites are commonly used for the following operations.

- i. Measurements of horizontal angles.
- ii. Measurements of vertical angles.
- iii. Measurements of magnetic bearing of lines.
- iv. Measurements of direct angles.
- v. Measurements of deflection angels.
- vi. Prolongation of straight lines.
- vii. Running a straight line between two points.
- viii. Laying off an angle by repetition method.

#### **1. Measurement of horizontal angles**

- 1) **To measure the angle by method of repetition: -**

Let ABC be the required angle between sides BA and BC to be measured by repetition method as shown in Fig 3.5. When the measure of an angle is small, slight error in its sine value introduce a considerable error in the computed sides as the sine value of the angle changes rapidly. Therefore, for accurate and precise work, the method of repetition is generally used. In this method, The value of the angle is added several times mechanically and the accurate value of the angular measure is determined by dividing the accumulated reading by the number of repetition.

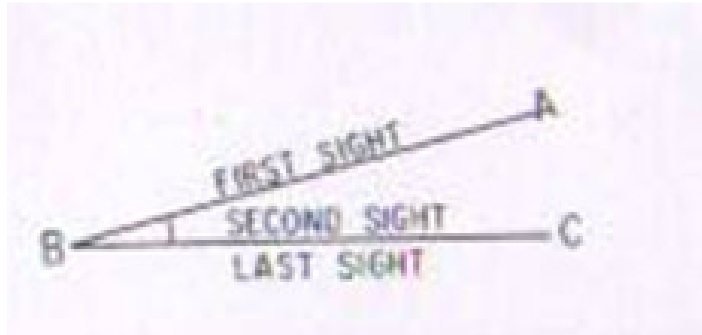

Fig. 3.5 Method of repetition

- 2) **To measure the angle by reiteration method:** When several angles having a common vertex, are to be measured the reiteration method is generally adopted. In this method angles are measured successively starting from a reference station and finally closing on the same station. The operation of making last observation on the starting station is known as closing horizon. Making observations on the starting station twice provides a check on the sum of all angles around a station. The sum should invariably be equal to  $360^\circ$ , provided the instrument is not disturbed during observations. As the angles are measured by sighting the stations in turn, this method is sometimes known as direction method of observation of the horizontal angles.
2. **Measurement of vertical angles:** A vertical angle may be defined as the angle subtended by the inclined line of sight and the horizontal line of sight at the station in vertical plane. If the point sighted is above the horizontal axis of the theodolite, the vertical angle is known as angle of elevation and if it is below, it is known as angle of depression.

**Procedure:** To measure a vertical angle subtended by the station B at the instrument station A, The following steps are involved:

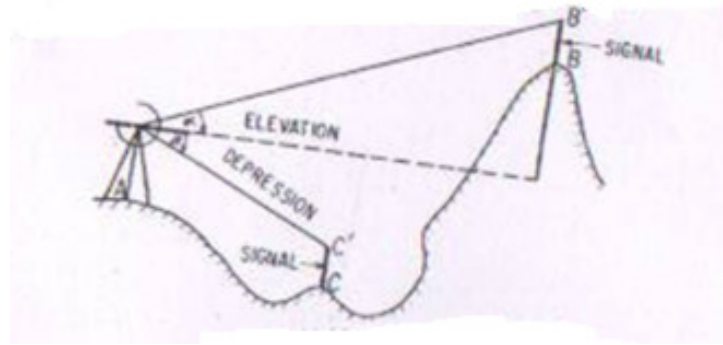

Fig. 3.6. Measurement of vertical angle.

- i. Set up the theodolite over the ground station mark A. Level it accurately by using the altitude bubble.
- ii. Set the zero of the vertical vernier exactly in coincidence with zero of the vertical scale using vertical clamp and vertical tangent screw. Check up whether the bubble of the altitude level is central of its run. If not, bring it to the centre of its run by means of the clip screw. In this position, the line of collimation of the telescope is horizontal and the verniers read to zero.
- iii. Loosen the vertical circle clamp and move the telescope in vertical plane until the station B is brought in field of view. Use vertical circle tangent screw for accurate bisection.
- iv. Read both the verniers of the vertical circle. The mean of two vernier readings gives the value of the vertical angle.
- v. Change the face of the instrument and make the observations exactly in similar way as on the face left.
- vi. The average of two values of the vertical angle is the required value of the vertical angle.

**3. Measurement of magnetic bearing of a line:** To measure the magnetic bearing of a line AB, the theodolite should be provided with either a circular or a trough compass.

The following steps are involved:

- (i) Centre and level the instrument accurately on station A.
- (ii) Set the vernier to read zero.
- (iii) Loosen the lower plate and also release the magnetic needle.
- (iv) Swing the telescope about its vertical axis until the magnetic needle points S-N graduations of the compass box scale.
- (v) Clamp the lower plate. Using the lower tangent screw bring the needle exactly against the zero graduation in exact coincidence with the north end of the needle.
- (vi) In this position, the line of collimation of the telescope lies in the magnetic meridian at the place while verniers still reads to zero. The setting of the instrument is now said to be oriented on the magnetic meridian.

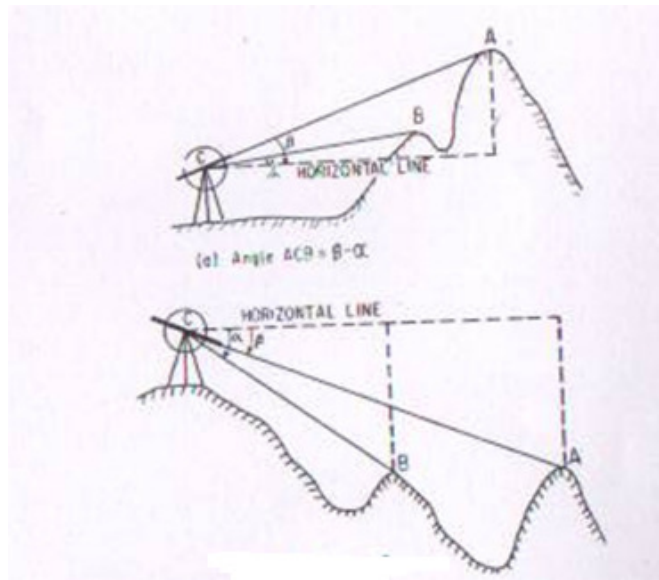

(b) Angle  $ACB = \alpha - \beta$

Fig. 3.7 Measurement of vertical angle

- (vii) Loosen the upper plate, swing the instrument and bisect B accurately, using the upper tangent screw.

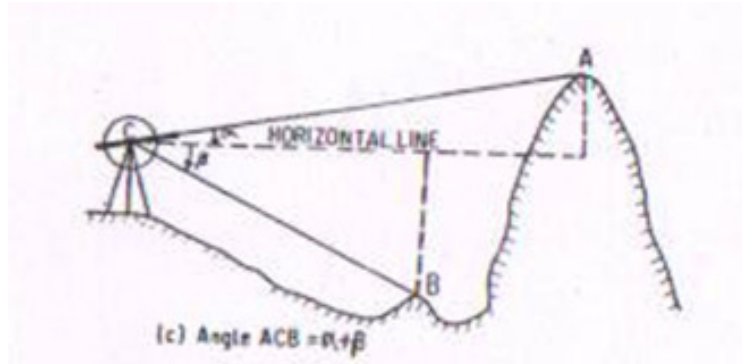

Fig. 3.7 Measurement of vertical angle

- (viii) Read both the vernier. The means of the two readings is the required magnetic bearing of the line AB.
- (ix) Change the face of the instrument and observe the magnetic bearing exactly in a similar way as on the left face.
- (x) The mean of magnetic bearings observed on both faces is the accurate value of the magnetic bearing of line AB.
4. **Measurement of direct angles:** The angle measured clockwise from the preceding line to the following line is called a direct angle. These angles are also sometimes known as azimuths from the back line, or angles to the right and may vary from  $0^\circ$  to  $360^\circ$ .

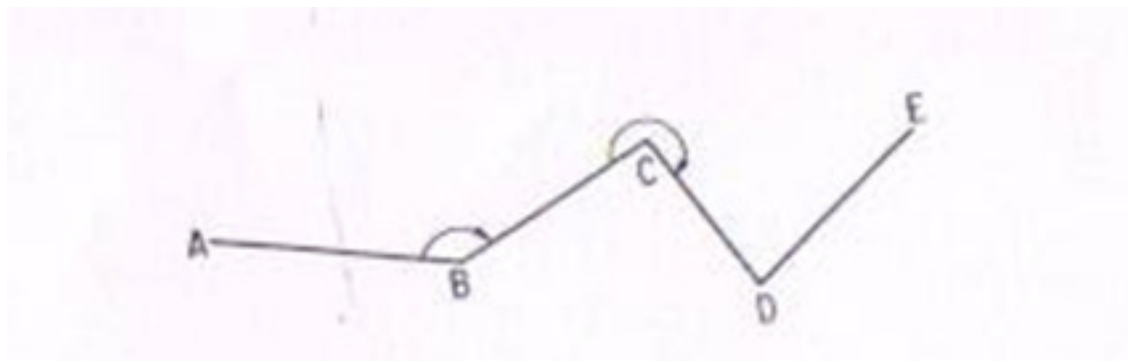

Fig. 3.8 Measurement of direct angles

5. **Measurement of deflection angles:** The angle which any survey line makes with the prolongation of the preceding line is called deflection angle. Its value may vary from  $0^\circ$  to  $180^\circ$  and is designated as right deflection angle if it is measured in clockwise direction and as left deflection angle if it is measured in an anticlockwise direction. In fig. the deflection angles  $\alpha$  and  $\delta$  at stations B and E respectively are left deflection angles whereas angles  $\beta$  and  $\gamma$  at stations C and D are right deflection angles.

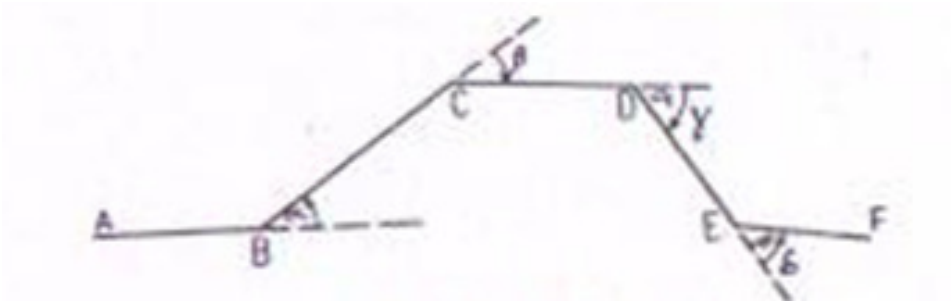

Fig. 3.9 Measurement of deflection angles

6. **Prolongation of a straight line:** Prolongation of any straight line AB to a point F may be done by any one of the following methods:

**First method: -**

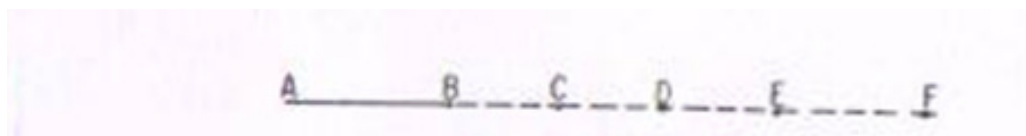

Fig. 3.10 Prolongation of a line

The following steps are involved:

- i. Set up the theodolite at A, center and level it accurately.



- ii. Bisect an arrow centered over the mark at B.
- iii. Establish a point C in the line of sight at a convenient distance.
- iv. Shift the instrument to B.
- v. Centered the theodolite over B, level it and sight C. Establish another point D.
- vi. Proceed in a similar manner until the desire point F is established.

**Second method:-**

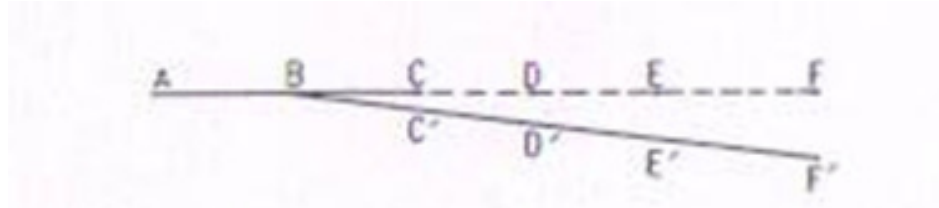

Fig. 3.11 Prolongation of a line

The following steps are involved:

- I. Set up the theodolite at B and centered it carefully.
- II. Bisect A accurately and clamp both the plates.
- III. Plunge the telescope and establish a point C in the line of sight.
- IV. Shift the instrument to C and center it carefully.
- V. Bisect B and clamp both the plates.
- VI. Plunge the telescope and establish the point D in the line of sight.
- VII. Continue the process till the last point F is established.

NOTE: -

The following points may be noted.

- I. If the instrument is in perfect adjustment, the points B, C, D, E and F will lie in a straight line.
- II. If the line of collimation is not perpendicular to the horizontal axis, the established point C', D', E' and F' would lie on a curve.

**Third method: -**

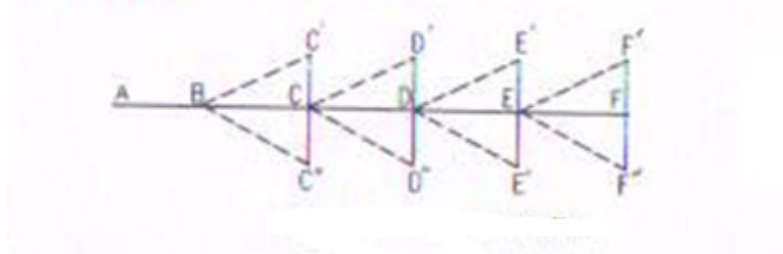

Fig. 3.12 Prolongation of a line

Following steps are involved

- I. Set up the theodolite at B and center it carefully.
- II. Bisect A on face left and clamp both the plates.
- III. Plunge the telescope and establish a point C'.
- IV. Change the face and bisect A again.
- V. Plunge the telescope and establish a point C'' at the same distance as C' from B.
- VI. If the instrument is in adjustment, the point C' and C'' will coincide.
- VII. If not, establish a point C midway between C' and C''.
- VIII. Shift the instrument to C and repeat the process to establish a point D.
- IX. Repeat the process until the required point F is established.

NOTE: - The following points may be noted.

- I. This method of prolongation of a line requires two sightings and as such it is known as double sighting method.
- II. This method is used only when greater precision is required with a poorly adjusted instrument.

**SOURCES OF ERROR IN THEODOLITE WORK:** The sources of error in theodolite work may be broadly divided into three categories, i.e.

1. Instrument error.
2. Personal error
3. Natural errors

**Instrumental errors:** - The theodolites are very delicate and sophisticated surveying instrument. In spite of best efforts during manufacturing perfect adjustment of fundamental axes of the theodolite, is not possible. The unadjusted errors of the instrument are called residual errors. We shall now discuss how best to avoid the effect of these residual error while making field observations. Instrumental errors may also be divided into different types as discussed below:

1. **Error due to imperfect adjustment of plate level:** - If the plate bubbles are not adjusted properly, the vertical axis of the instrument does not remain vertical even if plate bubbles remain at the center of their run. Non verticality of the vertical axis introduced error in the measurements of both the horizontal and vertical angles. Due to non verticality of vertical axis the horizontal plate gets inclined and it does not remain in horizontal plane. The error is especially important while measuring the horizontal angles between stations at considerable different elevations.  
**Elimination of the error:** - this error can be eliminated only by leveling the instrument carefully, with the help of the altitude or telescope bubble, before starting the observations.
2. **Error due to line of collimation not being perpendicular to the trunnion axis:** - If the line of collimation of the telescope is not truly perpendicular to the trunnion axis, it generates a cone when it is rotated about the horizontal axis. The trace of the intersection of the conical surface with the vertical plane containing the station sighted the hyperbolic. This imperfect adjustment introduces errors in horizontal angles measured between stations at different elevations.

#### **Personal errors:**

Personal errors are due to mainly following causes.

- (i) inaccurate centring over a station
- (ii) slip of instrument when not put firmly on the tripod
- (iii) faulty manipulation of instrument controls like clamping the instrument and operating wrong tangent screw
- (iv) inaccurate leveling, inaccurate bisection of target
- (v) non-verticality of ranging rod
- (vi) displacement of target stations, parallax
- (vii) errors in sighting, reading and recording

#### **Natural errors**

Errors due to natural causes include the followings.

- (i) settlement of tripod due to soft soil
- (ii) wind causing vibrations and turning
- (iii) high temperature causing faults in reading due to refraction, differential expansion of different parts
- (iv) direct sunlight on the instrument making sighting and reading difficult.

## CHAPTER-4

### TRAVERSE COMPUTATIONS

After the field work is over, the positions of different points are plotted on a map with reference to lines  $XX_1$  and  $YY_1$  as shown in fig. which are perpendicular and parallel to the meridian and are called “axes of coordinates”. The point of intersection of these lines,  $O$ , is called the “origin”. This origin may either be any traverse station or entirely outside the survey area. The distances of various points from  $YY_1$  and  $XX_1$  are called the “x-coordinates” and “y-coordinates” respectively. The coordinates of various traverse stations can be used for calculations of the area of the closed traverse and also for checking the field measurements

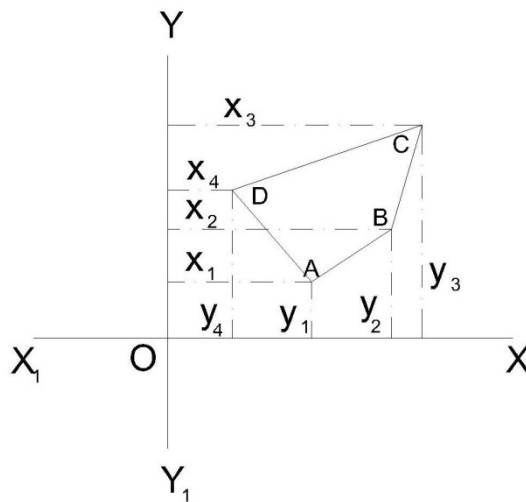

Traverse computation

If the length and bearing of a line are known, the projection of such a traverse line may be obtained on the line parallel to the meridian  $YY_1$ , and on the line perpendicular to the meridian  $XX_1$ .

#### Latitude:

The projection of the line parallel to the meridian (N-S line) is called the “latitude” of the line.

#### Departure:

The projection of the line perpendicular to meridian (N-S line) is called the “departure” of the line.

The latitude when measured upward or northward along the meridian, is positive and termed as “northing” and when it is measured downward or southward along the meridian it is negative and is called “southing”.

The departure when measured eastward or towards right, is positive and is known as “easting” and when it is measured westward or to the left, it is negative and is known as “westing”.

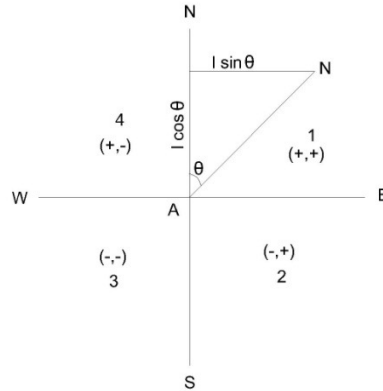

### Traverse computation

if the length of line AB is known and its reduced bearing from meridian (i.e,  $\theta$ ) is known, the latitude and the departure may be determined.

Latitude of a line = Length of line x The cosine of reduced bearing of line  
 = Length x  $\cos \theta$

Departure of a line = Length of line x The sine of reduced bearing of line  
 = Length x  $\sin \theta$

The letter N or S of the reduced bearing will give the sign of the latitude as +ve or -ve respectively and the letter E or W will give the sign of the departure as +ve or -ve, respectively. If the bearings of various traverse lines have been measured as whole circle bearings, the same should be expressed in the form of reduced bearings and consequently can be utilized in determining the latitudes and the departures.

The following table in such a case, may be used.

Whole circle bearing (WOB)	Quadrant	Sign of	
		Latitude	Departure
0° to 90°	(1) or NE	+	+
90° to 180°	(2) or SE	-	+
180° to 270°	(3) or SW	-	-
270° to 360°	(4)	+	-

### Consecutive and independent coordinates

The latitude and departure of any point with reference to the preceding point are known as “consecutive coordinates”. And the coordinates of any point with reference to a common origin are called the “independent coordinates” of the point. The independent coordinates are also known as “total latitude” and “total departure” of the points.

The independent coordinates of any point may be determined by adding (algebraically) the latitudes and departures of the lines between that point and the origin. Thus,

x-coordinate (or total = x-coordinate of the first point of the departure) of any point

traverse+ Algebraic sum of the departures of the lines between the first point and that point

y-coordinate (or total = y-coordinate of the first point of the latitude) of any point  
 traverse + Algebraic sum of latitudes of the lines between the first point  
 and that point

The above rule follows that

x-or y-coordinate of last = x. or y-coordinate of the first point  
 point of the traverse + Algebraic sum of all departures or  
 Latitudes

Note

The theodolite traverse should always be plotted with the help of rectangular coordinates.

**Adjustment of closing errors in a closed traverse:**

If the survey work is correct, in a closed traverse, the algebraic sum of latitudes (I e,  $\Sigma L$ ) should be equal to zero and also the algebraic sum of latitudes (I e,  $\Sigma D$ ) should be equal to zero. It follows that the sum of northings should be equal to sum of southings and the sum of eastings should be equal to sum of westings.

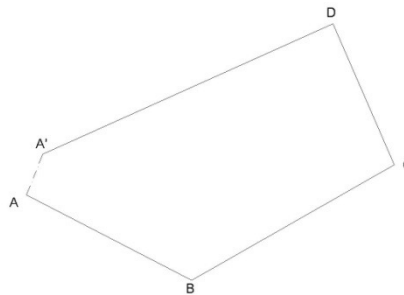

closing errors in a closed traverse

There are always errors in a theodolite traverse mainly due to two sources, viz :

- (1) the angles between the sides, and
- (2) the lengths of the sides.

Out these, the first is usually less important than the second. The traverse is plotted according to the field measurements, the same will not close on paper and the end point of the traverse will not coincide exactly with the starting point. The distance by which the last point of the traverse falls short to coincide with the starting point is called the “error of closure” or “closing error”. As per the Fig shows plotting of traverse ABCD. The traverse is not closing at A but instead it ends at some other point A1 and thus AA1 is the closing error. The components of this error A1A2 and AA2 as in Fig parallel and perpendicular to the meridian may be obtained by finding the algebraic sum of the latitudes  $\Sigma L$ , and the algebraic sum of departures  $\Sigma D$ .

$\Delta AA1A2$  is right-angle at A2 .

Linear error of closure  $AA1 = \sqrt{\dots}$

Where  $\Phi$  is the reduced bearing.

The signs of  $\Sigma L$  and  $\Sigma D$  will determine the position of closing in a particular quadrant.

The closing error is usually expressed as a fraction having the numerator as unity and is called the relative error of closure.

**Note**

The errors in lengths of sides are more likely to occur along the longest sides of the traverse.

**Angular error**

If the angles of a traverse do not add up correctly, ie, a difference exists between the sum of the measured angles and the theoretical sum of  $(2n\pm 4)$  right angles, where n is the number of sides of closed traverse ; necessary correction to the angles nearest the short sides (since these are the angles most likely to be slightly more in error) is to be applied. If the angular error is small, the same may be arbitrarily distributed to two or three angles. If the survey work is carried out with ordinary precision, the correction applied to any angle is not less than the least count of the vernier.

**.3 Adjustment of error in bearings**

The closing error in bearing may be obtained by comparing the two bearings of the last line as observed at the first and the last stations of the traverse or if the traverse ends on a line of known bearing, the closing error can be obtained by finding the difference between its observed bearing and known bearing. This error ..... then, should be distributed among the sides of the traverse. If n is the number of sides, the corrections to the bearings of the sides will be as given below :

- Correction to the first bearing =
- Correction to the second bearing =
- Correction to the third bearing =
- Correction to the last bearing =

**BALANCING THE TRAVERSE**

When the closing error in latitude and in departure is determined, the latitudes, and departures should be adjusted such that the algebraic sum of the latitudes should be adjusted such that the algebraic sum of the latitudes and departures should each be equal to zero. This operation of applying correction to the latitudes and the departures is called the “balancing of the traverse”. If one or more sides of a traverse have not been measured with equal care due to some typical field conditions, the whole or the largest part of the error may be adjusted to the same side or sides. But, if all the sides have been measured with equal precision and care, the following rules may be applied to determine the corrections for balancing the traverse.

(1) Bowditch’s rule

The Bowditch’s Rule or the “compass rule” is generally used to balance the traverse when the angular as well as linear measurements are taken with equal precision. By this rule, the total error in latitude and in departure is distributed in proportion to the length of the sides.

Correction to the latitude or to the departure of any line

= Total error in latitude or departure

X Length of the line

Perimeter of the traverse

The traverse can also be adjusted as it is explained in “compass traverse adjustment”.

(2) Transit rule

The transit rule may be applied to balance the traverse when the angular measurements are taken with greater care and precision than the linear measurements as in the case of a theodolite and stadia traverse. According to this rule,

Correction to latitude of any line

= Total error in latitude X Latitude of that line

Arithmetical sum of all the latitudes

Similarly,

Correction to departure of any line

= Total error in departure X Departure of that line

Arithmetical sum of all the departure

(3) Third rule

According to the third rule,

Correction to northing of any side

= Total error in latitude X Northing of that side

Sum of all northings

Correction to southing of any line

= Total error in latitude X southing of that side

Sum of all southings

Similarly,

Correction to easting of any side

= Total error in departure X Easting of that side

Sum of all easting

Correction to westing of any side

= Total error in departure X Westing of that side

Sum of all wrstings

When the traverse is thus balanced, the lengths and bearings of lines are changed.

Note

In case the traverse adjustments are made by the Bowditch’s Rule, angles are changed more and the lengths are charged less than when the adjustment is made by the transit rule.

**Gales Traverse Table:**

The following steps may observed.

- (1) Find out the sum of the observed included angles which should be equal to  $(2n \pm 4)$  right angles according as the interior or exterior angles are measured. If they are not



- equal, apply the necessary corrections to the angles so that the sum of the corrected angles is exactly equal to  $(2n \pm 4)$  right angles.
- (2) From the observed bearing of the first line AB and the corrected included angles, calculate the WCB of all the other lines BC, CD, etc. As a check, find out the bearing of the first line which should be equal to its observed bearing.
  - (3) Calculate the reduced bearings of lines from the whole circle bearing and find out the respective quadrants.
  - (4) Compute the latitudes and departures of lines, I e, the consecutive coordinates (coordinates with respect to preceding point, e g, in a closed traverse ABCD, the coordinates of A, with respect to D and coordinates of B with respect to station A, and so on) from their observed lengths and corrected reduced bearings. For example in the above traverse, to compute the coordinates of A, the length and reduced bearing of line DA should be taken, and similarly for point B, the length and reduced bearing of line AB should be considered.
  - (5) Find out the algebraic sum of latitudes ( $\Sigma L$ ) and that of departures ( $\Sigma D$ ). Apply necessary corrections to the latitudes and departures so that their sum is equal to zero for closed traverse.
  - (6) From the corrected consecutive coordinates, obtain the independent coordinates of the lines such that they are all positive and the whole traverse lies in the first quadrant (NE).

#### Example

The following corrected latitudes and departures correspond to the sides of a traverse ABCDE. Compute the independent coordinates.

Lines	Latitude		Departure	
	Northing	Southing	Easting	Westing
AB		325.16	620.24	
BC	449.35		946.24	
CD	980.25			742.60
DE		536.89		797.80
EA		567.55		26.08

The independent coordinates of an origin or the starting point A of the survey should be so chosen that the coordinates of all other Station points are positive, i.e. all the points of the traverse lie in the first quadrant.

Also the chosen independent coordinates should be in multiples of 100 and 1000.

Here, the coordinates of point A may be chosen as (400,0). Applying the rule,

North coordinate of point A	= 400.00
Deduct southing of point B	= 325.16
North coordinate of point B	= 78.84
Add northing of point C	= 449.35

North coordinate of point C	= 524.19
Add northing of point D	= 980.25
North coordinate of point D	= 1504.44
Deduct southing of point E	= 536.89
North coordinate of point E	= 967.55
Deduct southing of point A	= 567.55
North coordinate of point A	= 400.00 (same as assumed)
East coordinate of point A	= 0.00
Add easting of point B	= 620.24
East coordinate of point B	= 620.24
Add easting point C	= 946.24
East coordinate of point C	= 1 566.48
Deduct westing of point D	= 742.60
East coordinate of point D	= 823.88
Deduct westing of point E	= 797.80
East coordinate of point E	= 26.08
Deduct westing of point A	= 26.08
East coordinate of point A	= 0.00 (same as assumed)

**Area of closed traverses:**

The following methods are generally used for calculating the area of closed traverses :

- a) Area from coordinates (y and x).
- b) Area from latitudes and double meridian.
- c) Area from departures and total latitudes.

**a) Area of closed traverses from coordinates:**

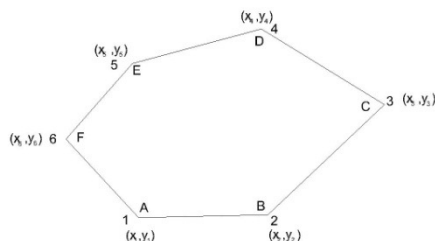

If the coordinates  $(x_1, y_1)$ ,  $(x_2, y_2)$ , etc. of various points in a closed traverse are known, the area can be easily calculated.

In Fig ABCDEF is a closed traverse of six sides and the coordinates are also indicated for each station.

To find the area, multiply (ordinate/abscissa) by the difference of (abscissae/ordinates) of the points before and after the point considered, e.g., when point A is considered, the ordinate of point A is multiplied by the difference of abscissae of points B and F, i.e.,  $y_1(x_2 - x_6)$ .

Always the preceding abscissae/ordinates are subtracted from the following abscissae/ordinates.

Find the sum of all such products which is equal to twice the area of the traverse.

Half of this sum gives the required area of the traverse.

Thus, the area of closed traverse is given below:

$$\text{Area} = \frac{1}{2}[y_1(x_2 - x_6) + y_2(x_3 - x_1) + y_3(x_4 - x_2) + y_4(x_5 - x_3) + y_5(x_6 - x_4) + y_6(x_1 - x_5)]$$

$$\text{Area} = \frac{1}{2}[y_1(x_2 - x_6) + y_2(x_3 - x_1) + y_3(x_4 - x_2) + \dots + y_n(x_{n+1} - x_{n-1})]$$

Where  $x_1, x_2, x_3$ , etc. are the abscissae and  $y_1, y_2, y_3$  etc. are the ordinates.

The abscissae or x-coordinates are along X-axis or east-west line.

The ordinates or y-coordinates are along Y-axis or north-south line.

**b) Area of closed traverse from latitudes and double meridian distances (DMD):**

The meridian distance (MD) of a line or “longitude” is the perpendicular distance of the middle point of the line from the reference meridian.

The double meridian distance (DMD) or the double longitude of a line is equal to the sum of the meridian distance of the two ends of the lines. The MD of various lines can be calculated by the following principles:

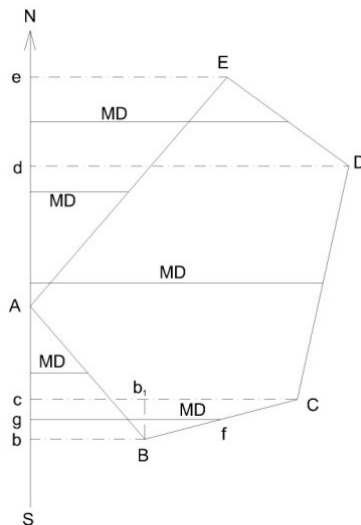

(1) The DMD of first line is equal to the departure of that line.

- (2) The DMD of each succeeding line is equal to DMD of the preceding line plus the departure of the line itself.
- (3) The DMD of the last line is numerically equal to the departure of the last line but with opposite sign.

**Rule**

To find out the area of the closed traverse by latitudes and DMD, multiply each DMD by the latitude of that line.

Find the algebraic sum of all these products which gives twice the area of the traverse.

Half of this sum is equal to the required area of traverse.

The figure clearly shows the meridian distance from the reference meridian.

For example, the meridian distance of line BC will be fg and the DMD of line BC is  $(Cc + Bb) \cdot (Cc + Bb) = Cb_1 + b_1c + Bb$   
 $= Cb_1 + Bb + Bb = (Bb + Bb + b_1C)$

DMD of line BC = DMD of line AB + Departure of line AB + Departure of line BC

It proves the given principal.

**c) Area of closed traversed from departures and total latitudes:**

To find out the area of closed traverse by this principal proceed as follows:

- (1) Find out the total latitude of each station of the traverse.
- (2) Find the algebraic sum of departures of the two lines meeting at that station.
- (3) Multiply the total latitude of that station by the corresponding algebraic sum of the departures.
- (4) Find the algebraic sum of these products which is equal to twice the area of the traverse.

**Example**

The latitudes and departures of the survey lines of a traverse ABCD are given as follows:

Line	Latitude		Departure	
	N	S	E	W
AB	204.6		113.9	
BC		234.9	205.8	
CD		150.7	86.0	
DA	181.0	233.7		

Calculate its area if the sides are measured in meters.

**(1) Area of traverse ABCD by coordinates (independent):**

The independent coordinates can be calculated as already explained. Here, the independent coordinates of A can be assumed as (200,0) so that all the coordinates are positive and the traverse may lie in first quadrant only. The coordinates can be tabulated as given below.

Line	Latitude	Departure	Station	Independent coordinates	
				North, Y	East, x
AB	+ 204.6	+ 113.9	A	200.0	0.0
BC	- 234.9	+ 205.8	B	404.6	113.9
CD	- 150.7	- 86.0	C	169.7	319.7
DA	+ 181.0	- 233.7	D	19.0	233.7
		Cheek :	A	200.0	0.0

Now, the area of the traverse

$$\begin{aligned} &= \frac{1}{2}[y_1(x_2 - x_4) + y_2(x_3 - x_1) + y_3(x_4 - x_2) + y_4(x_1 - x_3)] \\ &= \frac{1}{2}[200(113.9 - 233.7) + 404.6(319.7 - 0.0) \\ &+ 169.7(233.7 - 113.9) + 19(0.0 - 319.7)] \\ &= \frac{1}{2}[200 \times -119.8 + 404.6 \times 319.7 + 169.7 \times 119.8 + 19 \times -319.7] \\ &= \frac{1}{2}[-23\,960.0 + 129\,350.62 + 20\,330.06 - 6\,074.30] \\ &= \frac{1}{2}[149\,680.68 - 30\,034.30] = \frac{1}{2}[119\,646.38] = 59\,823.19 \\ \therefore \text{Area of the traverse ABCD} &= 59\,823.19 \text{ m}^2 \end{aligned}$$

**(2) Area of traverse ABCD by latitudes and double meridian distance:**

In this method, first of all the DMD of each line should be calculated.

$$\text{DMD of line AB} = \text{Departure of line AB} = 113.9$$

$$\begin{aligned} \text{MD of line BC} &= \text{DMD of line AB} + \text{Departure of line B} + \text{Departure of BC} \\ &= 113.9 + 113.9 + 205.8 = 433.6 \end{aligned}$$

$$\begin{aligned} \text{DMD of line CD} &= \text{DMD of line BC} + \text{Departure of line BC} + \text{Departure of line Cd} \\ &= 433.6 + 205.8 - 86.0 = 639.4 - 86.0 = 553.4 \end{aligned}$$

$$\begin{aligned} \text{DMD of line DA} &= \text{DMD of line CD} + \text{Departure of line CD} + \text{Departure of line DA} \\ &= 553.4 - 86.0 - 233.7 = 553.4 - 319.7 \\ &= 233.7 \end{aligned}$$

Check

The DMD of last line DA should be numerically equal to its departure but should be of opposite sign.

Hence, the above calculations are correct.

Now, the results may be tabulated as follows:

Line	Latitude	Departure	Twice the area (Column 2 X Column 4)		
			+	-	
1	2	3	4	5	6
AB	+ 204.6	+ 113.9	113.9	23 303.94	
BC	- 234.9	+ 205.8	433.6		101 852.64
CD	- 150.7	- 86.0	553.4		83 379.38
DA	+ 181.0	- 233.7	233.7	42 299.70	
		Total		65 603.64	185 250.02
		Algebraic sum		119 646.38	

∴ Area of traverse ABCD =  $\frac{1}{2}$  X Algebraic sum

$$= \frac{1}{2} \times 119\,646.38 = 59\,823.19 \text{ m}^2$$

Note

The negative sign of the has no significance.

**(3) Area of traverse ABCD from departures and total latitudes:**

Here, station A can be assumed as the reference station and the total latitudes of other stations B, C and D are calculated.

Total latitude of station A =  $\Sigma L = 00$

Total latitude of station B =  $\Sigma L = + 204.6$

Total latitude of station C =  $\Sigma L = 204.6 - 234.9 = -30.3$

Total latitude of station D =  $\Sigma L = 204.6 - 234.9 - 105.7 = - 181.0$

Check.

Total latitude of station A =  $\Sigma L = 204.6 - 234.9 - 105.7 + 181.0 = 0.0$

The results may be tabulated as under:

Line	Latitude	Departure	Total latitude	Algebraic sum of adjoining departure			
1	2	3	4	5	6	7	8
AB	+204.6	+113.9	B	+204.6	+319.7	65 410.62	
BC	-234.9	+205.8	C	-30.3	+119.8		3 629.94
CD	-150.7	-86.0	D	-181.0	-319.7	57 865.70	
DA	+181.0	-233.7	A	0.0	-119.8		0.0
						Total	
						123 276.32	3 629.94

Algebraic sum 119 646.38

∴ Area of the traverse =  $\frac{1}{2} \times$  Algebraic sum

$$= \frac{1}{2} \times 119\,646.38$$

$$= 59\,823.19 \text{ m}^2$$

Types of problems in traversing

While solving the problems, the following trigonometrically relationship should be remember and employed according to need.

The trigonometrically relationship of the course of a line together with its latitude and departure are employed are follows:

(1) Latitude = Length  $\times$  cosine of reduced bearing

(2) Departure = Length  $\times$  sine of reduced bearing

(3) Tangent of reduce bearing =  $\frac{\text{Departure}}{\text{Latitude}}$

(4) Length =  $\sqrt{(\text{Latitude})^2 + (\text{Departure})^2}$

Length = Latitude  $\times$  secant of reduced bearing

Length = Departure  $\times$  cosecant of reduced bearing

The various types of problems may be as follows :

(a) To find out the length and bearing of a line joining two-points whose independent coordinates are given :

In such a case proceed as given below:

(1) Find the difference between the north coordinates ;

- (2) Find the difference between the east coordinates ;
- (3) Then, if  $\theta$  be the reduced bearing of the line joining the two points,

$$\begin{aligned} \tan \theta &= \frac{\text{Departure of the line}}{\text{Latitude of the line}} \\ &= \frac{\text{Difference between the east coordinates}}{\text{Difference between the north coordinates}} \end{aligned}$$

### **Omitted or missing measurements:**

If the length and bearing of each side of the closed traverse are known, the traverse may be said to be completely surveyed. The bearing of all the sides may either be observed in the field or these may be computed from the observed bearing of any one line and the deflection angles or included angles of the traverse. It is always advisable to find out the length and bearings of the sides of a closed traverse by field measurements. But it is not always possible and due to certain obstacles direct measurements cannot be taken sometimes. For example such a difficulty may be experienced in direct observation of length and bearing of a line joining two points which are not inter visible owing to an intervening obstruction like a building. Similar difficulty may also be experienced if omissions occur in the field notes. To overcome these difficulties, the method of latitudes and departures may be readily employed to determine the omitted measurements provided the omitted measurements are not more than two in number. If the omitted measurements are more than two in number, the problem becomes indeterminate.

The sides of which the length or bearing or both are omitted, are called “affected sides”. The solution of problems of missing measurements is based on the principle that in a closed traverse the algebraic sum of the latitudes ( $\Sigma L$ ) and that of departures ( $\Sigma D$ ) should each be equal to zero.

Mainly there are two types of problems, viz :

- (1) In which only one side is affected, e g :
  - (a) The bearing of one side may be missing ;
  - (b) The length of one side may be missing ; and
  - (c) The length and bearing of one side may be missing.
- (2) In which two sides are affected, e g :
  - (a) The length of one side and bearing of another side may be missing;
  - (b) The bearings of two sides may be missing ; and
  - (c) The lengths of two sides may be missing.

To solve all such problems, the trigonometrical relationships, which are already given, should be used.

The following procedure may be adopted for these cases:

Case 1



In this case, the bearing, or length, or bearing and length of one side is missing. Let in Fig the length or the bearings or both the length and bearing of line ED be missing. Then, to determine the missing parts, adopt the following procedure.

Calculate the latitudes and departures of the other known sides EA, AB, BC and CD taking into account the correct signs. Find out the sum of latitudes ( $\Sigma L$ ) and that of departures ( $\Sigma D$ ). Then from the condition of closed traverse, the latitude and departure of the affected side will be  $-\Sigma L$ , and  $-\Sigma D$  respectively. Calculate the bearing of the affected side from the relationship, tangent of RB  $= \frac{\Sigma \text{Departure}}{-\Sigma \text{Latitude}}$ .

and the length of the affected side from the relationships,  $\text{Length} = \sqrt{(\Sigma \text{Latitude})^2 + (\Sigma \text{Departure})^2}$ , or  $\text{Length} = \text{Latitude} \times \text{secant of RB}$ , or  $\text{Length} = \text{Departure} \times \text{cosecant of RB}$ .

Case 2

(a) Length of one side and bearing of another side omitted

Let in Fig 7.69, the length of line BC and bearing of line CD be omitted. To solve such problems proceed as given below:

- (1) Join B and D to form a closed polygon DEAB, leaving the affected sides. Calculate the length and bearing of closing line BD as in case 1.
- (2) Compute the angle ( $\alpha$ ) between the closing line BD and line BC from their calculated and known bearings respectively.
- (3) Now, in  $\Delta BCD$ , the lengths of sides BD and CD are known and angle  $\alpha$  is known. Angle  $\Upsilon$  and length of side BC may be calculated by applying the sine rule.

When  $\Upsilon$  is calculated from the above relationships, angle  $\beta$  may also be calculated,  $\beta = 180^\circ - (\alpha + \Upsilon)$

- (4) From the known bearing of side BC and the calculated value of angle  $\Upsilon$ , calculate the required bearing of line CD. Check the result by calculating the bearing of line CD from the calculated values of bearing of line DB and angle  $\beta$ .

(b) Bearing of two sides missing

Refer Fig 7.69 and let BC and CD be the sides whose bearings are not known. Proceed as given below:

(2) Now since the lengths of all the sides in  $\Delta BCD$  are known the area of triangle BCD may be calculated easily by the well-known formula:

$$\text{Area, } \Delta = \sqrt{s(s-a)(s-b)(s-c)}$$

Where  $s$  is half the perimeter of the triangle and  $a, b, c$  are the lengths of the sides of the triangle.

- (3) Since the bearings of sides BC and CD are not known, angles  $\alpha, \beta$  and  $\Upsilon$  cannot be calculated with the help of bearings. First of all, the angles should be found out and then the bearings can be easily calculated. Determine the angles by equating the calculated area to half the products of any two sides and the sine of the angle between them, e.g., to find out angle  $\alpha$ , the relationship  $\Delta = \frac{1}{2} BD \times BC \times \sin \alpha$  may be used and so on.
- (4) Next, find out the bearings of sides BC and CD from the known bearing of closing line BD and the calculated angles  $\alpha$  and  $\beta$ .

(c) Lengths of two sides missing

Refer Fig and let sides BC and CD be affected, I e, let their lengths be not known.

(1) Ignoring the affected sides, close the polygon and calculate the length and bearing of closing line BD.

(2) Here, since the bearings of all the sides in  $\Delta BCD$  are known, angles  $\alpha$ ,  $\beta$  and  $\Upsilon$  can be calculated easily. After calculations apply the check :

$$\alpha + \beta + \Upsilon = 180^{\circ}$$

(3) Next, compute the lengths of sides BC and CD by applying the sine rule :

$$BC = \frac{BD \times \sin \beta}{\sin \Upsilon}$$

$$CD = \frac{BD \times \sin \alpha}{\sin \Upsilon}$$

Notes

(1) In case, the two sides of a traverse are affected and are not adjacent as shown in Fig (sides 1 and 4), the following procedure should be adopted.

Shift the known sides 5 and 6 parallel to themselves and in the direction parallel to one of the unknown sides and close the polygon by dotted closing line as shown in the figure. The affected side 4 will be thus shifted towards side 1 and will be adjacent to each other. The length and bearing of a line does not change when it is moved parallel to itself.

## CHAPTER- 5

### General

Tachometry is the branch of angular surveying in which the horizontal and vertical distances of points are obtained by optical means as opposed to the ordinary slower process of measurements by tape or chain. The method is very rapid and convenient. Although the accuracy of Tachometry in general compares un-favourably with that of chaining, it is best adapted in obstacles such as steep and broken ground, deep ravines, stretches of water or swamp and so on, which make chaining difficult or impossible.

The primary object of tachometry is the preparation of contoured maps or plans requiring both horizontal as well as vertical control. Also, on surveys of higher accuracy, it provides a check on distances measured with the tape.

### Tacheometer:

1. A tacheometer is nothing more than a theodolite fitted with stadia hair.
2. The stadia hairs are kept in the same vertical plane as the horizontal and vertical cross hair.
3. For short distance up to 100 m, ordinary leveling stadia may used.
4. According to measurement process system, it is classified under two categories

*i.e.* 1. Stadia hair system

2. Tangential system

5. The stadia hair system again divided into two categories

*i.e.* 1. Fixed hair method

2. Movable hair method

### Fixed hair method:

In this method, the distance between the upper hair and lower hair, i.e. stadia interval  $i$ , on the diaphragm of the lens system is fixed. The staff intercept  $s$ , therefore, changes according to the distance  $D$  and vertical angle  $\theta$ .

### Movable hair method:

In this method, the stadia interval ' $i$ ' can be changed. The stadia hairs can be moved vertically up and down by using micrometer screws. The staff intercept  $s$ , in this case, is kept fixed. Two vanes (targets) are fixed on the staff at a fixed interval of 2 m or 3 m.

The fixed hair method is the one which is commonly used and, unless otherwise mentioned, stadia method means fixed hair method. Movable hair method is not in common use due to difficulties in determining the value of  $i$  accurately.

### Principle of Stadia Method

The stadia method is based on the principle that the ratio of the perpendicular to the base is constant in similar isosceles triangles. In figure (a), let two rays  $OA$  and  $OB$  be equally inclined to the central ray  $OC$ . Let  $A_2B_2$ ,  $A_1B_1$  and  $AB$  be the staff intercepts.

Evidently,

$$\frac{OC_2}{A_2B_2} = \frac{OC_1}{A_1B_1} = \frac{OC}{AB} = \text{constant } k = \frac{1}{2} \cot \frac{\beta}{2}$$

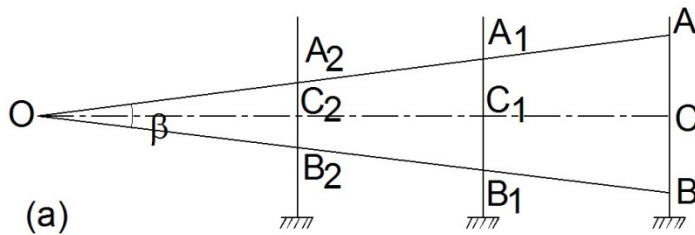

We will derive distance and elevation formulae for fixed hair method assuming line of sight as horizontal and considering an external focusing type telescope. In Figure below,  $O$  is the optical centre of the object glass. The three stadia hairs are  $a$ ,  $b$  and  $c$  and the corresponding readings on staff are  $A$ ,  $B$  and  $C$ . Length of image of  $AB$  is  $ab$ . The other terms used in this figure are

$f$  = focal length of the object glass,

$i$  = stadia hair interval =  $ab$ ,

$s$  = staff intercept =  $AB$ ,

$c$  = distance from  $O$  to the vertical axis of the instrument,

$d$  = distance from  $O$  to the staff,

$d'$  = distance from  $O$  to the plane of the diaphragm, and

$D$  = horizontal distance from the vertical axis to the staff.

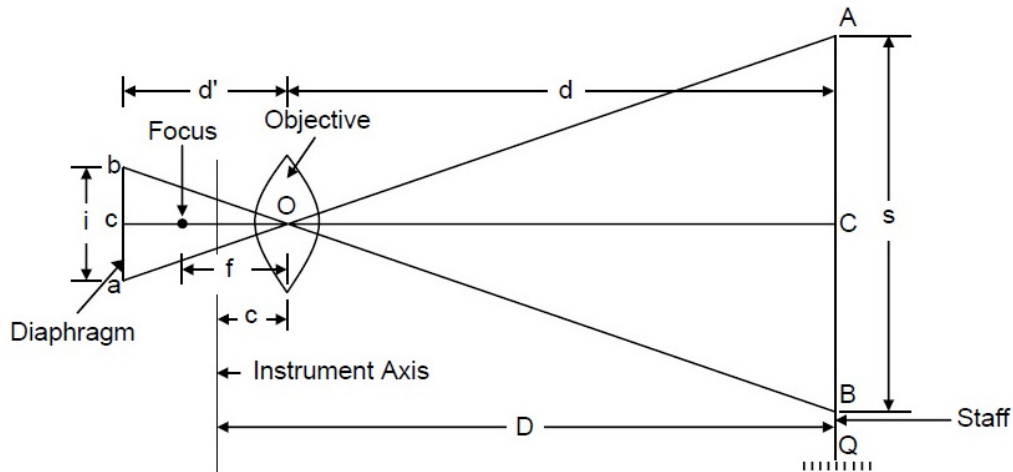

**Principle of Stadia Method**

From similar  $\Delta^s$ ,  $AOB$  and  $aOb$ , we get

$$\frac{d}{d'} = \frac{s}{i}$$

And from lens formula,

$$\frac{1}{f} = \frac{1}{d'} + \frac{1}{d}$$

Combining the two equations, we get

$$d = \frac{fs}{i} + f$$

Adding  $c$  to both the sides

$$D = \frac{fs}{i} + (f + c)$$

$$\text{Or } D = Ks + C$$

where the constant  $K$  is equal to  $(f/i)$ . It is called **multiplying constant** of the tacheometer and is generally kept as 100. The constant  $C$  is equal to  $(f + c)$ . It is called **additive constant** whose value ranges from 30 cm to 50 cm for external focusing telescopes and 10 cm to 20 cm for internal focusing telescopes. For telescopes fitted with anallactic lens,  $C$  equals zero.

### **Anallactic Lens**

The basic formula for determination of horizontal distance in stadia tacheometry is

$$D = \frac{fs}{i} + (f + c)$$

$$\text{Or } D = Ks + C$$

Due to the presence of the additive constant  $C$ ,  $D$  is not directly proportional to  $s$ . This is accomplished by the introduction of an additional convex lens in the telescope, called an *anallactic lens*, placed between the eyepiece and object glass, and at a fixed distance from the latter.

The anallactic lens is provided in external focusing telescope. Its use simplifies the reduction of observations since the additive constant ( $f + c$ ) is made zero and the multiplying constant  $k$  is made 100. However, there is objection to its use also as it increases the absorption of light in the telescope thereby causing reduction in brilliancy of the image. Anallactic lens is not fitted in internal focusing telescopes.

### **Determination of Tacheometric Constants**

The stadia interval factor ( $K$ ) and the stadia constant ( $C$ ) are known as tacheometric constants. Before using a tacheometer for surveying work, it is required to determine these constants. These can be computed from field observation by adopting following procedure.

**Step 1 :** Set up the tacheometer at any station say P on a flat ground.

**Step 2 :** Select another point say Q about 200 m away. Measure the distance between P and Q accurately with a precise tape. Then, drive pegs at a uniform interval, say 50 m, along PQ. Mark the peg points as 1, 2, 3 and last peg -4 at station Q.

**Step 3 :** Keep the staff on the peg-1, and obtain the staff intercept say  $s_1$  .

**Step 4 :** Likewise, obtain the staff intercepts say  $s_2$ , when the staff is kept at the peg-2,

**Step 5 :** Form the simultaneous equations,

$$D_1 = K \cdot s_1 + C \text{ -----(i)}$$

$$\text{and } D_2 = K \cdot s_2 + C \text{ -----(ii)}$$

Solving Equations (i) and (ii), determine the values of  $K$  and  $C$  say  $K_1$  and  $C_1$  .

**Step 6 :** Form another set of observations to the pegs 3 & 4, Simultaneous equations can be obtained from the staff intercepts  $s_3$  and  $s_4$  at the peg-3 and point Q respectively. Solving those equations, determine the values of  $K$  and  $C$  again say  $K_2$  and  $C_2$ .

**Step 7 :** The average of the values obtained in steps (5) and (6), provide the tacheometric constants  $K$  and  $C$  of the instrument.

## Stadia tacheometry

### Case 1 When staff held vertical and with line of collimation horizontal

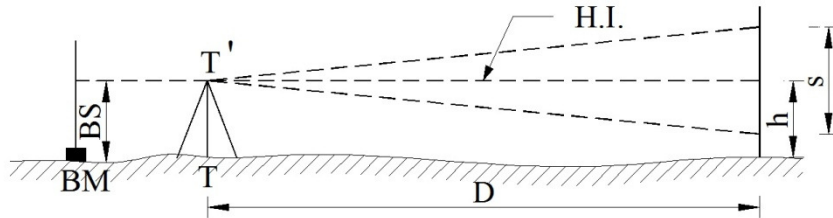

When the line of sight is horizontal, the general tacheometric equation for distance is given by

$$D = \frac{fs}{i} + (f + c)$$

The multiplying constant  $\left(\frac{f}{i}\right)$  is 100, and additive constant  $(f + c)$  is generally zero.

RL of staff station P = HI - h

Where HI = RL of BM + BS

h = central hair reading

BS = Back sight

HI = height of instrument

### Case 2 When staff held vertical and with line of collimation inclined

(a) Considering Angle of elevation

Let

T = Instrument station

$T_1$  = axis of instrument

P = staff station

A, B, C = position of staff cut by hairs

S = AC = staff intercept

h = central hair reading

V = vertical distance instrument axis and

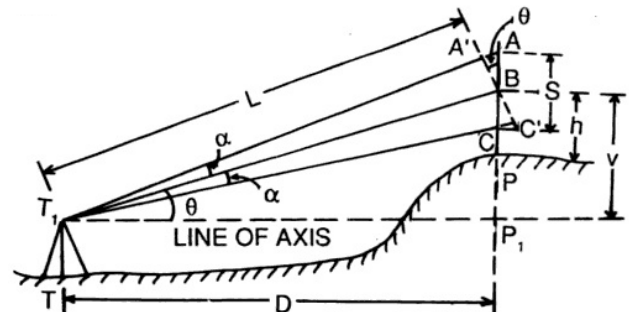

central hair

$D$  = horizontal distance between instrument and staff

$L$  = inclined distance between instrument axis and B

$\theta$  = angle of elevation

$\alpha$  = angle made by outer and inner rays with central ray

$A'C'$  is drawn perpendicular to the central ray  $T_1B$

Now, internal distance,  $L = \frac{f}{i}(A'C') + (f + c)$

Horizontal distance,  $D = L \cos\theta$

$$= \frac{f}{i}(A'C') \cos\theta + (f + c) \cos\theta \quad (1)$$

Now  $A'C'$  is to be expressed in terms of  $AC$  (i. e.  $S$ )

In  $\Delta s ABA'$  and  $CBC'$

$$\angle ABA' = \angle CBC' = \theta$$

$$\angle AA'B = 90^\circ + \alpha$$

$$\angle BC'C = 90^\circ - \alpha$$

The angle  $\alpha$  is very small

$\angle AA'B$  and  $\angle BC'C$  may be taken equal to  $90^\circ$

So  $A'C' = AC \cos\theta = S \cos\theta$

From equation (1)

$$D = \frac{f}{i}(S \cos\theta) \cos\theta + (f + c) \cos\theta$$

$$D = \frac{f}{i} \times S \cos^2\theta + (f + c) \cos\theta$$

Again  $V = L \sin\theta$

$$= \left\{ \frac{f}{i} \times S \cos\theta + (f + c) \right\} \sin\theta$$

$$= \frac{f}{i} \times S \cos\theta \sin\theta + (f + c) \sin\theta$$

$$V = \frac{f}{i} \times \frac{S \times \sin 2\theta}{2} + (f + c) \sin\theta$$

Also  $V = D \tan\theta$

$RL$  of staff station  $P = RL$  of axis of instrument +  $V - h$

(b) Considering Angle of depression



In this case also the expressions for D and V are same. That is

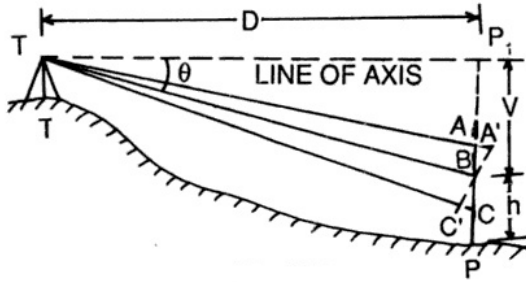

$$D = \frac{f}{i} \times S \cos^2 \theta + (f + c) \cos \theta$$

$$V = \frac{f}{i} \times \frac{S \sin 2\theta}{2} + (f + c) \sin \theta$$

$$RL \text{ of staff station } P = RL \text{ of axis of instrument} - V - h$$

### Problem

A tacheometer was set up at a station C and the following readings were obtained on a staff vertically held.

Inst. station	Staff station	Vertical angle	Hair readings	Remarks
C	BM	$-5^{\circ} 20'$	1.500 , 1.800, 2.450	RL of BM =
C	D	$+8^{\circ} 12'$	0.750, 1.500, 2.250	750.50 m

Calculate the horizontal distance CD and RL of D, when the constants of instrument are 100 and 0.15 .

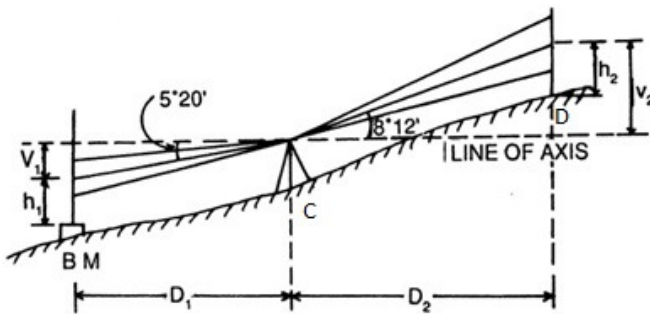

### Solution

When the staff is held vertically, the horizontal and vertical distances are given by the relations

$$D = \frac{f}{i} \times S \cos^2 \theta + (f + c) \cos \theta$$

$$V = \frac{f}{i} \times \frac{S \times \sin 2\theta}{2} + (f + c) \sin \theta$$

Here  $\frac{f}{i} = 100$  and  $(f + c) = 0.15$

In the first observation,  $S_1 = 2.450 - 1.150 = 1.300 \text{ m}$

$\theta_1 = 5^\circ 20'$  (depression)

$$V_1 = 100 \times 1.300 \times \frac{\sin 10^\circ 40'}{2} + 0.15 \times \sin 5^\circ 20' = 12.045 \text{ m}$$

In the second observation,  $S_2 = 2.250 - 0.750 = 1.500 \text{ m}$

$\theta_2 = 8^\circ 12'$  (elevation)

$$V_2 = 100 \times 1.500 \times \frac{\sin 16^\circ 24'}{2} + 0.15 \times \sin 8^\circ 12' = 21.197 \text{ m}$$

$$D_2 = 100 \times 1.50 \times \cos^2 8^\circ 12' + 0.15 \times \cos 8^\circ 12' = 147.097 \text{ m}$$

$$RL \text{ of axis of instrument} = RL \text{ of BM} + h_1 + V_1$$

$$= 750.500 + 1.800 + 12.045 = 764.345 \text{ m}$$

$$RL \text{ of D} = RL \text{ of axis of instrument} + V_2 - h_2$$

$$= 764.345 + 21.197 - 1.500 = 784.042 \text{ m}$$

So, the distance CD = 147.097 m and RL of D = 784.042 m

## CHAPTER-6

### Introduction:

Curves are required to be introduced where it is necessary to change the direction of motion from one straight section of a highway or a railway to another. These are provided due to the nature of terrain or other avoidable reasons to enable smooth passage of vehicles.

### CLASSIFICATION OF CURVES

For survey purposes, curves are classified as horizontal or vertical, depending on whether they are introduced in the horizontal or vertical plane.

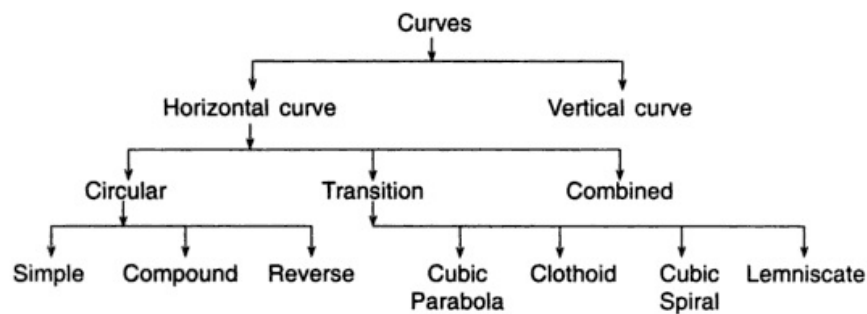

### Horizontal Curves

Horizontal curves can be circular or non-circular (transitional) curves. Different types of horizontal curve are shown in figure below.

#### *Simple Circular Curve*

When a curve consists of a single arc with a constant radius connecting the two straights or tangents, it is said to be a circular curve.

#### *Compound Curve*

When a curve consists of two or more arcs with different radii, it is called a compound curve. Such a curve lies on the same side of a common tangent and the centres of the different arcs lie on the same side of their respective tangents.

#### *Reverse Curve*

A reverse curve consists of two arc bending in opposite directions. Their centres lie on opposite sides of the curve. Their radii may be either equal or different, and they have one common tangent.

#### *Transition Curve*

A curve of variable radius is known as a transition curve. It is also called a easement curve. Such a curve is provided between a straight and a circular curve, or between branches of a compound or reverse curve to avoid an abrupt change in direction when the alignment

changes. In railways, such curve is used on both sides of a circular curve to minimize superelevation.

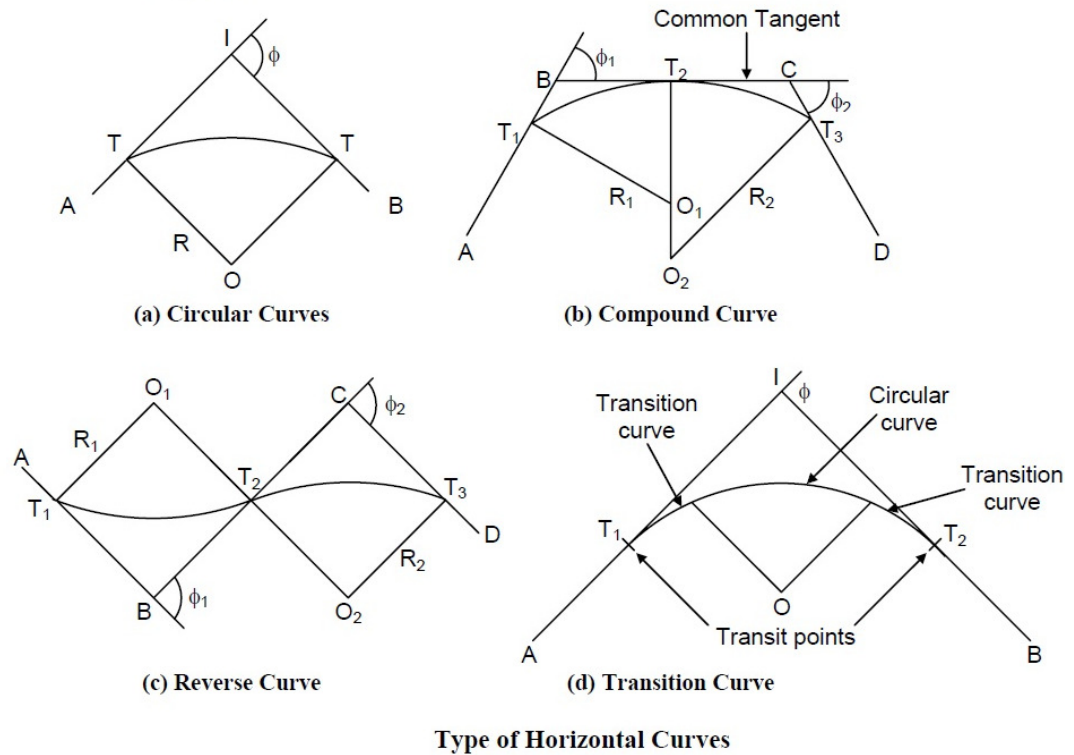

### SIMPLE CIRCULAR CURVE

Figure shows a simple circular curve with two straight lines  $AI$  and  $IB$  intersect at the point  $I$ . The curve  $T_1 C T_2$  of radius  $R$  is inserted to make a smooth change of direction from  $AI$  to  $IB$ . A

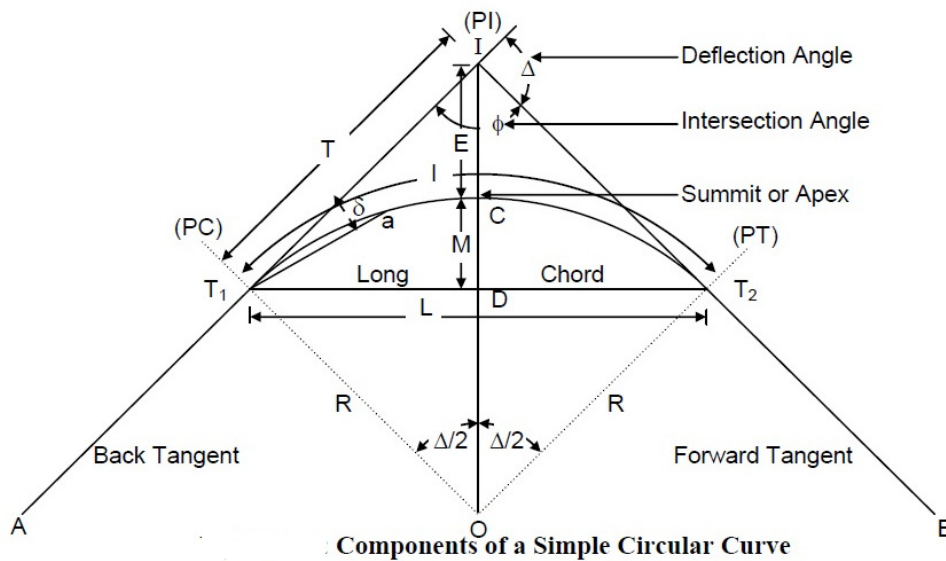

simple circular curve has various components whose definitions are given below.

## **Definition of Various Components**

### **Back Tangent**

The tangent ( $AT_1$ ) previous to the curve is called the back tangent or first tangent.

### **Forward Tangent**

The tangent ( $T_2B$ ) following the curve is called the forward tangent or second tangent.

### **Point of Intersection**

If the two tangents  $AT_1$  and  $BT_2$  are produced, they will meet in a point  $I$  called the point of intersection (PI) or vertex.

### **Point of Curve (PC)**

It is the beginning of the curve ( $T_1$ ) where the alignment changes from a tangent to a curve.

### **Point of Tangency (PT)**

It is the end of the curve ( $T_2$ ) where the alignment changes from a curve to tangent.

### **Intersection Angle**

The angle between the tangent  $AT_1$  and  $BT_2$  is called the intersection angle ( $\phi$ ).

### **Deflection Angle**

The angle  $\Delta$  through which the forward tangent deflects is called the deflection angle of the curve. It may be either to the left or the right.

### **Deflection Angle to any Point**

The deflection angle  $\delta$  to any point  $a$  on the curve is the angle at PC between the back tangent and the chord  $T_1a$  from PC to point on the curve.

### **Tangent Distance (T)**

It is the distance between PC to PI (also the distance from PI to PT).

### **External Distance (E)**

It is distance from the mid-point of the curve to PI. It is also known as the apex distance.

### **Length of the Curve (l)**

$L$  is the total length of the curve from PC to PT.

### **Long Chord (L)**

It is the chord joining PC to PT.

### **Mid Ordinate (M)**

It is the ordinate from the mid-point of the long chord to the mid-point of the curve. It is also called the versine of the curve.

### **Normal Chord (C)**

A chord between two successive regular stations on a curve is called a normal chord.

### **Sub-Chord (c)**

Sub-chord is any chord shorter than the normal chord. These generally occur at the beginning or at the end of the curve.

### **Right-hand Curve**

If the curve deflects to the right of the direction of the progress of survey, it is called the right-hand curve.

### **Left-hand Curve**

If the curve deflects to the left of the direction of the progress of survey, it is called the left-hand curve.

## **Elements of Simple Circular Curve**

### **Length of the Curve ( $l$ )**

$$\begin{aligned} \text{Length } l &= T_1 C T_2 = R \Delta, \text{ where } \Delta \text{ is in radians} \\ &= (\pi R) \Delta / 180^\circ, \text{ where } \Delta \text{ is in degrees.} \end{aligned}$$

### **Tangent Length ( $T$ )**

$$\begin{aligned} \text{Tangent length, } T &= T_1 I = I T_2 \\ &= O T_1 \tan \Delta/2 = R \tan \Delta/2 \end{aligned}$$

### **Length of the Long Chord ( $L$ )**

$$\begin{aligned} L &= T_1 T_2 = 2 O T_1 \sin \Delta/2 \\ &= 2 R \sin \Delta/2 \end{aligned}$$

### **Apex Distance or External Distance ( $E$ )**

$$\begin{aligned} E &= CI = IO - CO \\ &= R \sec \Delta/2 - R \\ &= R (\sec \Delta/2 - 1) \\ &= R \operatorname{exsec} \Delta/2 \end{aligned}$$

### **Mid-ordinate ( $M$ )**

$$\begin{aligned} M &= CD = CO - DO \\ &= R - R \cos \Delta/2 \\ &= R (1 - \cos \Delta/2) = R \operatorname{versin} \Delta/2 \end{aligned}$$

**Problem :**

Two tangents intersect at a chainage of 1250.50 m having deflection angle of  $60^\circ$ . If the radius of the curve to be laid out is 375 m, calculate the Length of the curve, Tangent distance, Length of the long chord, Apex distance, Mid-ordinate, Degree of curve and Chainage of P.C. and P.T.

**Solution :**

Length of the curve,  $l = (\pi R) \Delta / 180^\circ$ , where  $\Delta$  is in degrees.

$$\begin{aligned} &= \pi \times 375 \times 60 / 180^\circ \\ &= 392.69 \text{ m} \end{aligned}$$

Tangent Length,  $T = R \tan \Delta/2$

$$\begin{aligned} &= 375 \times \tan 60^\circ / 2 \\ &= 216.50 \text{ m} \end{aligned}$$

Length of the long chord,  $L = 2 R \sin \Delta/2$

$$\begin{aligned} &= 2 \times 375 \times \sin 60^\circ / 2 \\ &= 375.00 \text{ m} \end{aligned}$$

Apex distance,  $E = R (\sec \Delta/2 - 1)$

$$\begin{aligned} &= 375 \times (\sec 60^\circ / 2 - 1) \\ &= 58.01 \text{ m} \end{aligned}$$

Mid-ordinate,  $M = R (1 - \cos \Delta/2)$

$$\begin{aligned} &= 375 \times (1 - \cos 60^\circ / 2) \\ &= 50.24 \text{ m} \end{aligned}$$

Degree of Arc,  $D_a^\circ = 1718.9/R$

$$\begin{aligned} &= 1718.9/375 \\ &= 4.58^\circ \end{aligned}$$

Chainage of PC = Chainage of  $I - T$

$$\begin{aligned} &= 1250.50 - 216.50 \\ &= 1034.00 \text{ m} \end{aligned}$$

Chainage of PT = Chainage of  $I + l$

$$\begin{aligned} &= 1250.50 + 392.69 \\ &= 1634.19 \text{ m} \end{aligned}$$

## Designation of Curve

The *sharpness* of the curve is designated either by its *radius* or by its *degree of curvature*. The degree of curvature has several slightly different definitions. According to the *arc definition* generally used in highway practice, the degree of the curve ( $D_a^\circ$ ) is defined as the central angle of the curve that is subtended by an arc  $AB$  of 30 m length .

If the degree of curve ( $D_a^\circ$ ) is taken in degrees, for a curve of radius  $R$  meter, then

$$D_a^\circ : 30 = 360^\circ : 2\pi R$$

or 
$$D_a^\circ = 10800 / 2\pi R$$

$$= 1718.9 / R \text{ (approximate)}$$

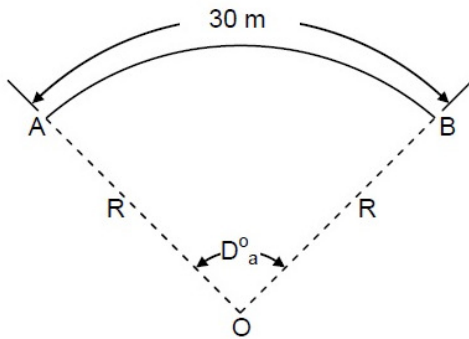

(a) Arc Definition

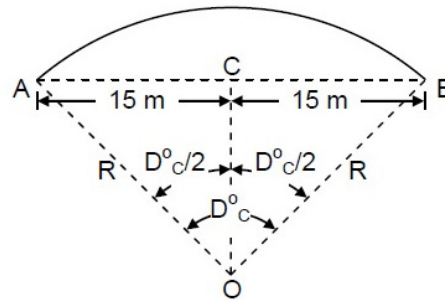

(b) Chord Definition

to

### Degree of Curve

According to the *chord definition* generally

used in railway practice, the degree of the curve ( $D_c^\circ$ ) is defined as the central angle of the curve that is subtended by its chord  $AB$  of 30 m length.

$$\sin(D_c^\circ/2) = AC/AO$$

$$= 15/R$$

$$R = 15 / \sin(D_c^\circ/2)$$

Radius of curvature varies inversely as the degree of curve. A sharp curve has a larger degree of curve whereas a flat curve has a smaller degree of curve.

## SETTING OUT SIMPLE CIRCULAR CURVE

A circular curve can be set out in the field by linear method and angular method. These are described below.

- (a) Linear method is also called chain and tape method. In this method, only tape and chains are used and no angular measurement is carried out.
- (b) In angular method or Instrumental method, a theodolite, tacheometer or a total station instrument is used for angular measurement.



## Linear Method

Listed below are some of the linear methods of setting out simple circular curve followed by their description :

- (a) Offsets from the long chord
- (b) Successive bisection of chord
- (c) Offsets from the tangents
- (d) Offsets from the chords produced

### Offsets from the Long Chord

The method is suitable for setting out circular curves of small radius, such as those at road intersections in a city or in boundary walls. In Figure below, the offset  $O_{xa}$  to the point  $a$  on the curve is the perpendicular distance of point  $a$  from the long chord  $T_1T_2$ , at a distance  $x_a$  from  $D$  along the long chord. Considering the origin at  $D$ ,  $O_{xa}$  is the y-coordinate of point  $a$ .

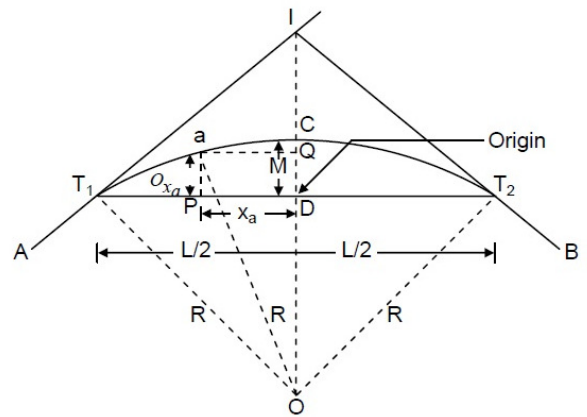

Offsets from the Long Chord

From  $\Delta OT_1D$ ,

$$(DO)^2 = (T_1O)^2 - (T_1D)^2$$

$$\text{Or } (OC - DC)^2 = (T_1O)^2 - (T_1D)^2$$

$$\text{Or } (R - M)^2 = R^2 - \left(\frac{L}{2}\right)^2$$

$$\text{Or } M = R - \sqrt{R^2 - \left(\frac{L}{2}\right)^2}$$

Draw a line  $Qa$  parallel to  $DT_1$  cutting  $DC$  at  $Q$

From  $\Delta O a Q$

$$OQ = \sqrt{(Oa)^2 - (Qa)^2} = \sqrt{R^2 - x_a^2}$$

$$OQ = OD + DQ = OD + O_{xa}$$

$$OQ = OD + O_{xa} = \sqrt{R^2 - x_a^2}$$

$$O_{x_a} = \sqrt{R^2 - x_a^2} - OD$$

$$O_{x_a} = \sqrt{R^2 - x_a^2} - (R - M)$$

$$O_{x_a} = \sqrt{R^2 - x_a^2} - \sqrt{R^2 - \left(\frac{L}{2}\right)^2}$$

$$\text{In general } O_x = \sqrt{R^2 - x^2} - \sqrt{R^2 - \left(\frac{L}{2}\right)^2}$$

The long chord is divided into equal parts of suitable length. The offset  $O_{x_a}$  corresponding to the distances  $x_a$  from  $D$  are calculated for different points on the long chord. These offsets are measured perpendicular to the long chord with the help of an optical square and points are located. Joining these points will produce the desired curve. The points on the right side of  $CD$  are set out by symmetry.

### Successive Bisection of Chords

The method being approximate is suitable for small curves. It involves the location of points on the curve by bisecting the chords and erecting perpendiculars at the midpoint of the chords.

In Figure,  $T_1T_2$  is the long chord and  $D$  is its midpoint.  $C$  is the point of intersection of the perpendicular line at  $D$ , with the curve.  $Dc$  is the mid-ordinate, which is equal to

$$M = R \left( 1 - \cos \left( \frac{\Delta}{2} \right) \right) = R - \sqrt{R^2 - \left(\frac{L}{2}\right)^2}$$

At  $D$ , a perpendicular offset equal to  $M$  is erected and the position  $C$  is located. Now consider the chords  $T_1C$  and  $T_2C$ , locate their midpoints  $d_1$  and  $d_2$  respectively. Erect two perpendiculars at  $d_1$  and  $d_2$  and measure the offsets equal to  $d_1c_1$  and  $d_2c_2$ , respectively. The offsets  $d_1c_1$  and  $d_2c_2$  are computed from the following formula :

$$d_1c_1 = d_2c_2 = R \left( 1 - \cos \left( \frac{\Delta}{2} \right) \right)$$

Now, by the successive bisection of these chords, more points can be located in a similar manner.

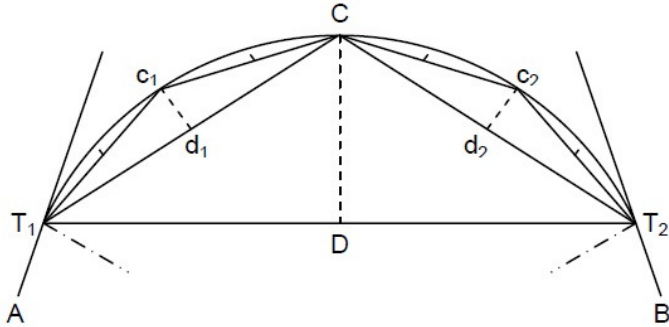

**Successive Bisection of Chords**

After locating  $T_1$  and  $T_2$ , the midpoint  $D$  of  $T_1T_2$  is obtained, by measuring  $T_1T_2$ . The perpendicular offset  $DC$  is set out at  $D$  with an optical square and point  $C$  is located. Measure  $T_1C$ , and  $T_2C$ , and locate their midpoints  $d_1$  and  $d_2$ . The perpendicular offsets  $d_1c_1$  and  $d_2c_2$  are set out at  $d_1$  and  $d_2$ , and the points  $c_1$  and  $c_2$  are established on the curve. The process is continued till sufficient numbers of points on the curve are fixed.

### Offsets from the Tangents

This method is used when the deflection angle and the radius of curvature both are comparatively small. In this method, the curve is set out by measuring offsets from the tangent. The offsets from the tangent can be either perpendicular or radial to the tangent.

### Perpendicular Offsets Method

Let the point  $a$  be on the curve and the perpendicular offset from the tangent  $T_1$  to it at  $P$  be  $O_{x_a}$ . Let the distance of  $P$  from  $T_1$  be  $x_a$ . Draw a line  $Qa$  perpendicular to  $T_1O$ , intersecting  $OT_1$  at  $Q$ .

From  $\Delta QaO$

$$OQ = \sqrt{(Oa)^2 - (Qa)^2}$$

$$R - O_{x_a} = \sqrt{R^2 - x_a^2}$$

$$R - O_{x_a} = R - \sqrt{R^2 - x_a^2}$$

$$\text{In general } O_x = R - \sqrt{R^2 - x^2}$$

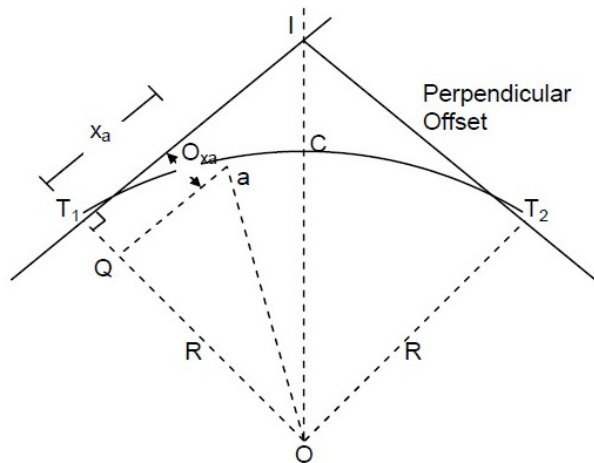

**Perpendicular Offsets**

Before setting out a curve, a table of offsets for different values of  $x$  (e.g., 10 m, 20 m, 30 m, etc.) is made. Then from  $T_1$  the distances  $x_1, x_2, x_3$  etc., are measured along the tangent and the corresponding offsets are measured on the perpendiculars to the tangent with the help of an optical square.

Since the offsets of points equidistant from  $T_1$  and  $T_2$ , are equal, the same table is used for offsets from both the tangents.

### Radial Offsets Method

Let the radial offset to the point  $a$  on the curve be  $O_{x_a}$  from the point  $P$  at a distance of  $x_a$  from  $T_1$ .

From  $\Delta OPT_1$

$$OP = \sqrt{(OT_1)^2 + (T_1P)^2}$$

$$R + O_{x_a} = \sqrt{R^2 + x_a^2}$$

$$O_{x_a} = \sqrt{R^2 + x_a^2} - R$$

$$\text{In general } O_x = \sqrt{R^2 + x^2} - R$$

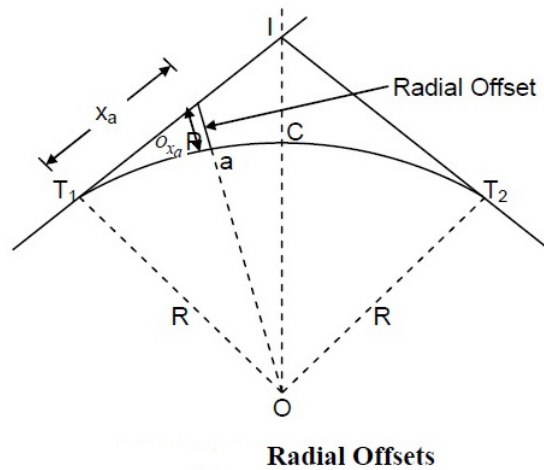

### Offsets from the Chord Produced

The method has the advantage that not all the land between the tangents points  $T_1$  and  $T_2$  need be accessible. However to have reasonable accuracy the length of the chord chosen should not exceed  $R/20$ . The method has a drawback that error in locating is carried forward to other points. This method is based on the premise that for small chords, the chord length is small and approximately equal to the arc length.

For setting out the curve, it is divided into a number of chords normally 20 to 30 m in length. For the continuous chainage required along the curve, the two sub-chords are taken, one at the beginning and the other at the end of the curve. The first sub-chord length is such that a full number of chainage is obtained on the curve near  $T_1$  and the second sub-chord length near  $T_2$ .

From the property of a circle, if the angle  $\angle FT_1a = \delta_1$

The angle at the centre  $\angle T_1Oa = 2\delta_1$

$$T_1Oa = 2\delta_1$$

$$C_1 = \text{chord } T_1a \approx \text{arc } T_1a \\ = 2\delta_1 R$$

$$\text{Or } \delta_1 = \frac{C_1}{2R}$$

The first offset  $O_1 = C_1\delta_1$

$$O_1 = C_1 \frac{C_1}{2R} = \frac{C_1^2}{2R}$$

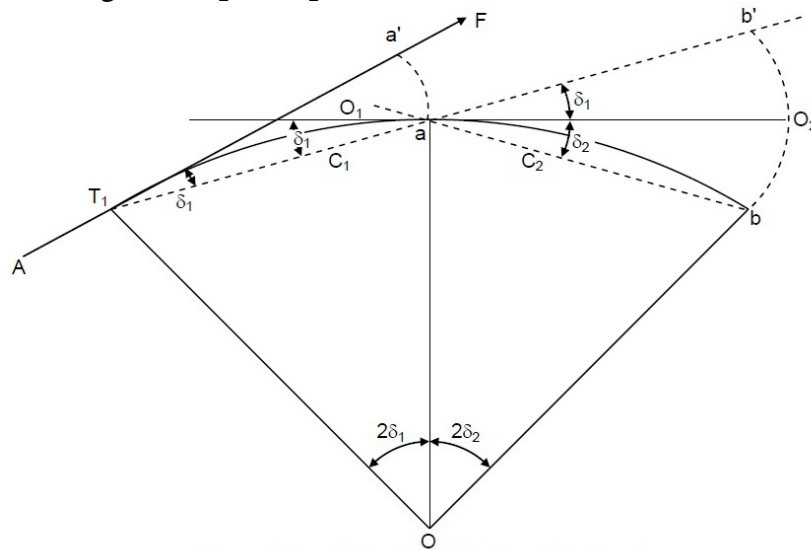

Offsets from the Chord Produced

The first chord  $C$  is called the sub-chord. The length of the sub-chord is so adjusted that the chord length when added to the chainage of  $T_1$  makes the chainage of point  $a$  as full chain.

Subsequent chord lengths  $C_2, C_3, C_4 \dots \dots \dots$  are full chains.  $T_1a$  is then produced to  $b'$  such that a full chain  $ab' = C_2$ , a full chain.

The second offset

$$O_2 = C_2(\delta_1 + \delta_2)$$

$$= C_2 \left( \frac{C_1}{2R} + \frac{C_2}{2R} \right)$$

$$= \frac{C_2}{2R} (C_1 + C_2)$$

$$\text{Similarly } O_3 = \frac{C_3}{2R} (C_2 + C_3)$$

$$\text{The last offset } O_n = \frac{C_n}{2R} (C_{n-1} + C_n)$$

where  $C_{n-1}$  is a full chain and  $C_n$  is the last sub-chord which is normally less than one chain length.

### Angular Method

Following are some of the angular method used to set out a simple circular curve :

- (a) Tape and theodolite method
- (b) Two theodolite method

(c) Tachometric method

(d) Total station Method

### Tape and Theodolite Method

In this method, a tape is used for making linear measurements and a theodolite is used for making angular measurements. The curve can be set out by the following procedures :

#### Rankine's Method

The method is known as Rankine's method of tangential angle or the deflection angle method. The method is accurate and is used in railways and highways.

Let  $T_1ab$  be a part of a circular curve with  $T_1$ , the initial tangent point. Thus,  $T_1a$  is the first sub-chord which is normally less than one chain length.

From the property of a circle

$$C_1 = 2\delta_1 R$$

$$\delta_1 = \frac{C_1}{2R} \text{radian}$$

$$= \frac{C_1}{2R} \frac{180^\circ}{\pi}$$

$$= \frac{C_1}{2R} \frac{180 \times 60}{\pi} \text{minutes}$$

$$= 1718.87 \frac{C_1}{R} \text{minutes}$$

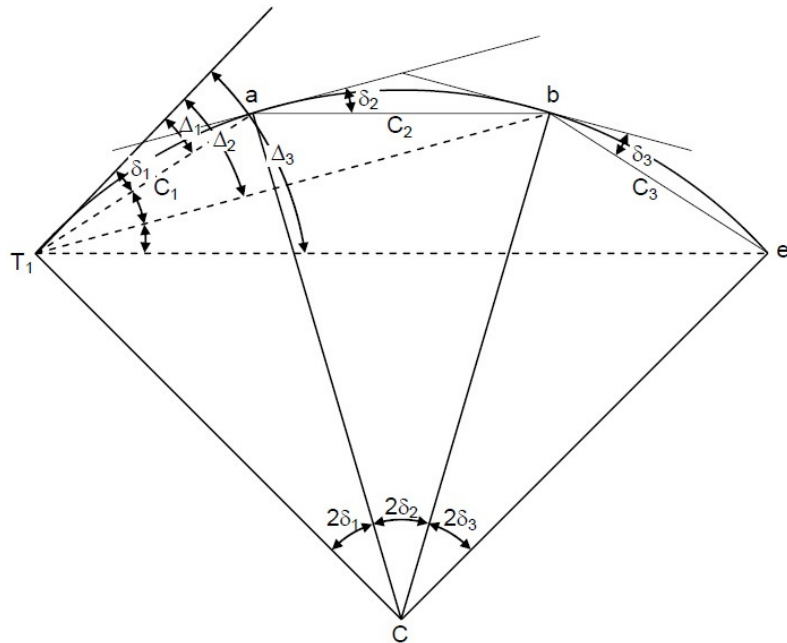

Rankine's Method

Therefore to locate the point  $a$  with the help of a theodolite and tape, the instrument is set

at  $T_1$  and the line of sight is put at an angle of  $\delta_1 = \Delta_1$  as computed above. Then with the help of a tape and ranging rod, the tape is put along the line of sight and distance  $C_1$  is then measured to locate point  $a$  along the line of sight.

Similarly,

$$\delta_2 = 1718.87 \frac{C_2}{R} \text{minutes}$$

Since the theodolite remains at  $T_1$ ,  $b$  is sighted from  $T_1$  by measuring  $\delta_1 + \delta_2 = \Delta_2$  from the tangent line. The point  $b$  is located with the help of a tape and ranging rod. The tape with the ranging rod is so adjusted that the tape measures  $ab = C_2$  and the ranging rod lies along the line of sight  $T_1 b$

Similarly,

$$\Delta_3 = \delta_1 + \delta_2 + \delta_3 = \Delta_2 + \delta_3$$

$$\Delta_n = \delta_1 + \delta_2 + \delta_3 + \dots + \delta_n = \Delta_{n-1} + \delta_n$$

In practice,  $C_1$  is the first sub-chord and  $C_n$  the last sub-chord.

$C_2 = C_3 = \dots = C_{n-1}$  are full chain lengths. As a check the deflection angle  $\Delta_n$  for the last point  $T_2$  is equal to  $\frac{\Delta}{2}$  where  $\Delta$  is the angle of intersection.

### Field Problems in Setting Out the Circular Curves

The following are some of the field problems in setting out the circular curves.

- (a) Point of curve inaccessible.
- (b) Point of tangency inaccessible.
- (c) Point of intersection inaccessible.
- (d) Curve tangential to three lines.
- (e) Both point of commencement and point of intersection inaccessible

#### Point of intersection inaccessible

If the point of intersection P.I. is inaccessible then to set out a curve, the following procedure is followed : First locate points  $P$  and  $Q$  on  $IT_1$  and  $IT_2$  respectively, then measure angles  $\alpha$  and  $\beta$  with the theodolite and length  $PQ$  with a tape .

Then  $\frac{IP}{\sin\beta} = \frac{PQ}{\sin\Delta}$

Or  $IP = \frac{PQ \sin\beta}{\sin\Delta}$

Similarly

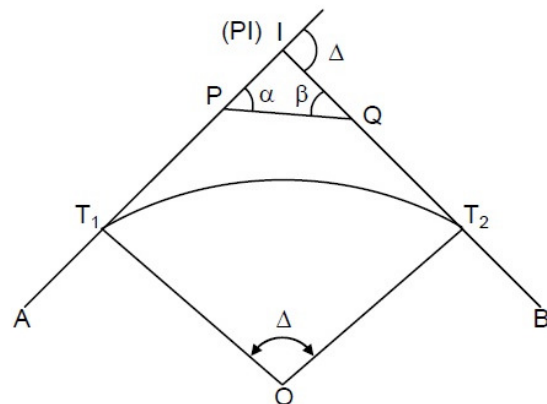

Point of Intersection Inaccessible 3

$$IQ = \frac{PQ \sin \alpha}{\sin \Delta}$$

Calculate  $PT_1 = IT_1 - IP$

$$QT_2 = IT_2 - IQ$$

Thus,  $T_1$  and  $T_2$  can be located from  $P$  and  $Q$  respectively and the curve can be plotted from  $T_1$ .

## TRANSITION CURVE

A transition or easement curve is a curve of a varying radius introduced between a straight and a circular curve, or between branches of a compound curve or reverse curve. The introduction of a transition curve between the straight and the circular arc, as indicated in Figure below, permits the gradual elevation of the outer edge or gradual introduction of *cant or super-elevation* (raising the outer edge over the inner). At the same time, it also permits gradual change of direction from straight to the circular curve and vice-versa.

On a straight track, its two edges are at the same level. On a circular arc the outer edge is elevated depending on the radius of the curve and the speed to the vehicles expected, to avoid over turning of the vehicles due to centrifugal force acting on them while moving on circular path. Also, there is an abrupt change in direction when the alignment changes from straight to circular curve and vice-versa.

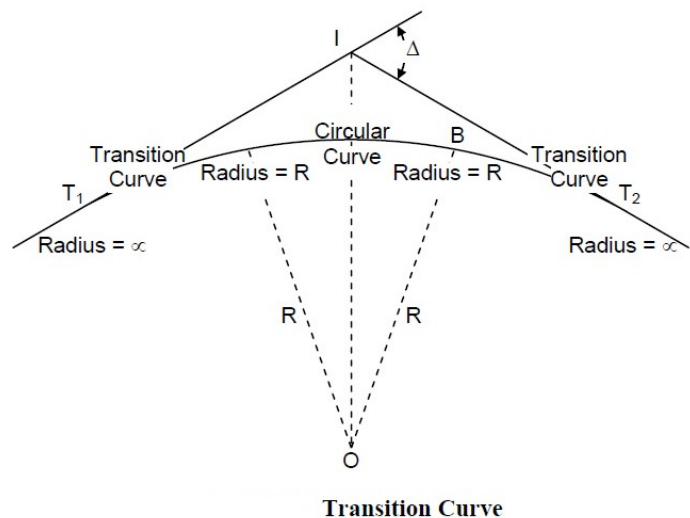

In railways, such a curve is provided on both sides of a circular curve to minimise super-elevation. Excessive super-elevation may cause wear and tear of the rail section and discomfort to passengers.

### Advantages of a Transition Curve

The introduction of a transition curve between a straight and a circular curve has the following advantages :

- The chances of overturning of the vehicles and the derailment of trains are reduced considerably.
- It provides comfort to the passengers on vehicles while negotiating a curve.
- The super-elevation is introduced gradually in proportion to the rate of change of curvature.
- It permits higher speeds at curves.



(e) It reduces the wear on the running gears

### **Characteristics of a Transition Curve**

(a) It should be tangential to the straight.

(b) It should meet the circular curve tangentially.

(c) Its curvature should be zero at the origin on tangent.

(d) Its curvature should be equal to that of the circular curve at the junction with the circular curve.

(e) The rate of change of curvature from zero to the radius of the circular curve should be the same as that of increase of cant or super-elevation.

(f) The length of the transition curve should be such that full cant or super-elevation is attained at the junction with the circular curve.

## CHAPTER-7

### SETTING OUT WORKS

Using different method of surveying, data are obtained about the ground features that are represented in maps and plans of the ground. Such drawings are prepared of various elements of the project.

Marking the outlines of excavation on the ground for the guidance of the contractor and labour is defined as **setting out of works** .

- On completion of the estimates from the approved plan excavation for the foundation is required to be made on the ground.
- In order to minimize the cost of digging foundation trenches out lines of excavation stakes should accurately marked.

#### ( i )Buildings:

To set out the building following materials are required

- (a) A foundation plan is prepared marking the centre lines and excavation width to facilitate setting out on ground.
- (b) Depending upon the method used, the instruments are selected.
- (c) For important buildings, a theodolite, tape, a cord to stretch, and marking powder, such as lime

There are two methods of setting out of building

- a) Circumscribing rectangle method
- b) Centre line method

#### (a ) Circumscribing rectangle method :

The procedure for the circumscribing rectangle method is as follows:

- Established control points A and B near the structure but at sufficiently large distance such that are not disturbed during the excavation.
- Erect perpendiculars at A and B to get points C and D of sufficient length so that they are away from the excavation limits. This can be done with a tape alone using the 3-4-5 principle, or more accurately using a prismatic compass or theodolite.
- Check the rectangle set out by measuring the diagonals AC and BD, which should equal to their calculated lengths.
- Correct any error proceeding further.
- The centre lines of the four walls of the building from the rectangle EFGH, Locate the four corners from the respective corners of ABCD.

- Check the lengths of this sides and the diagonals of EFGH.
- Set temporary stakes at points E, F, G, and H and mark these points with a nail.
- Tie cord between the nails and mark the centre line with dry lime powder.
- Mark the inner and outer boundaries of the foundation widths in the same way.
- Again mark the four corners of these rectangles with temporary stakes. Note that these stakes will go away once the excavation starts.

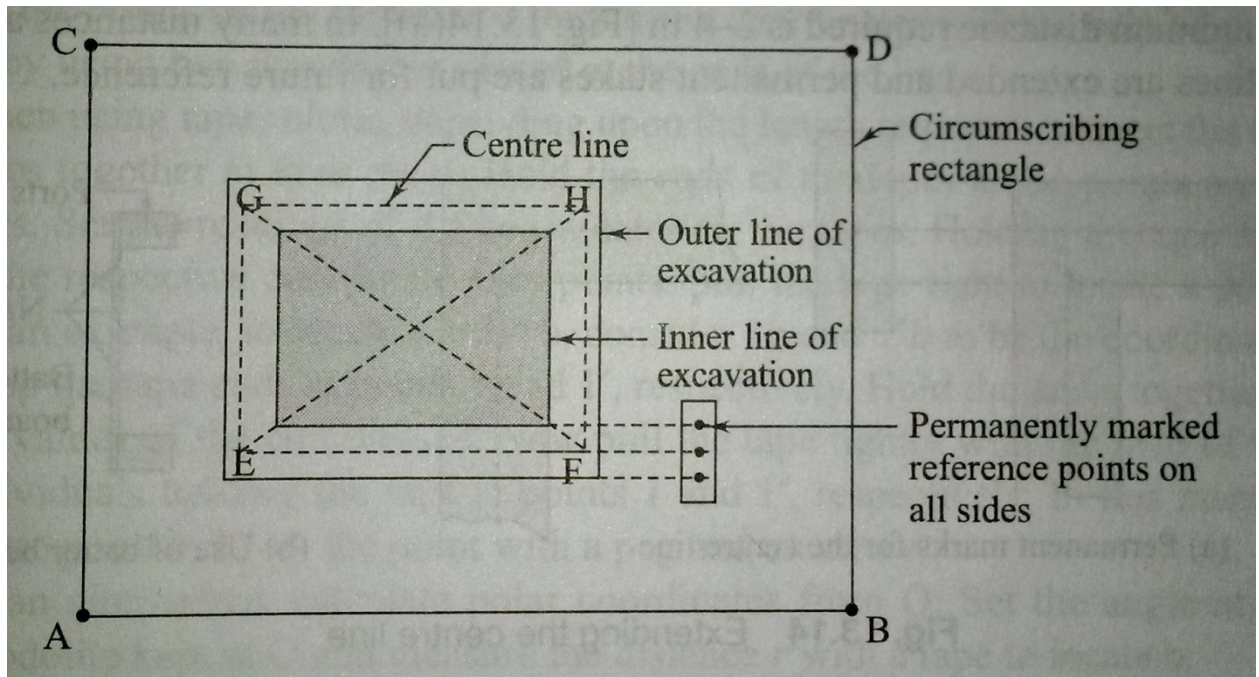

Fig. Circumscribing rectangle method

(b) Centre lines method :

- In the centre lines of the four walls of the building can be used as a reference rectangle.
- The corners of the centre line are accurately set out with respect to the control points near the site.

- In many instances all the three lines are extended and permanent stakes are put for future reference.

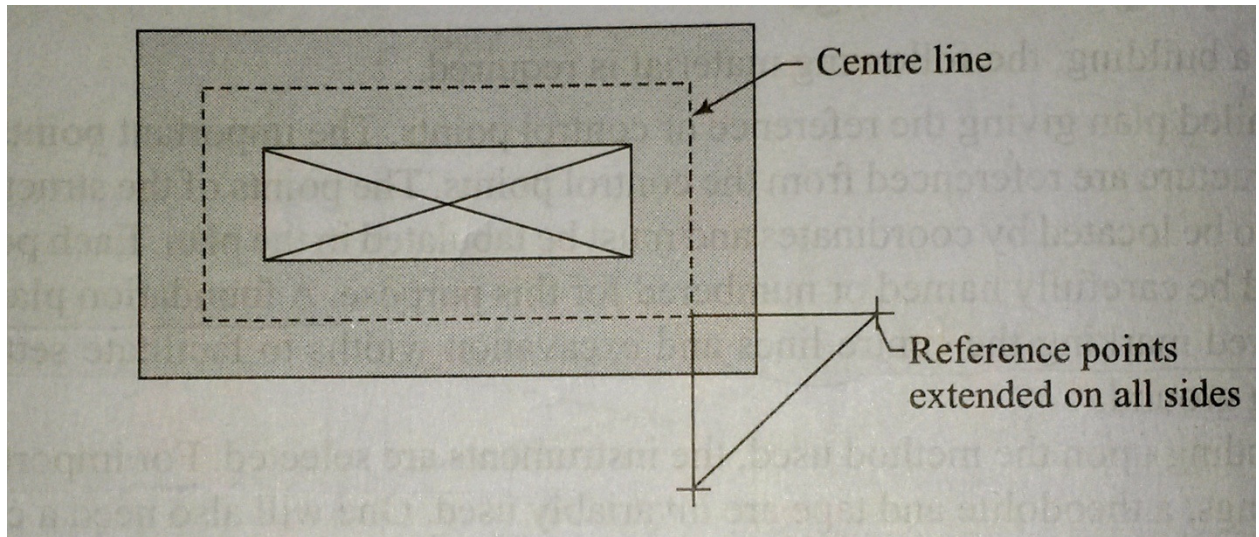

Fig. Centre line method

### Setting Out Culverts

For setting out of Culvert foundations, abutments, and wing coordinates of a number of points on the lines are required. For this purpose, the origin is selected at the intersection of the centre lines of a waterway or a road or railway line passing over it.

The following procedure is adopted.

- From the foundation plan of the culvert and the roadways, locate the two centre lines AOA' and BOB' where O being the origin as shown in fig.
- Locate these centre lines, from the control points available, near the sites coordinates.
- Check and verify that these two lines are at right angles.
- Drive a peg at O and mark it carefully.
- Set up a theodolite at O, centre and level it.
- Set up a number of points along both the lines. Assume that 1, 2, 3, 4, etc. are the points along AOA' and 1', 2', 3', 4', etc, are the points along BOB'.
- Mark the points with pegs and arrows such that a cord tied along the arrows defines the lines and the points marked on them.

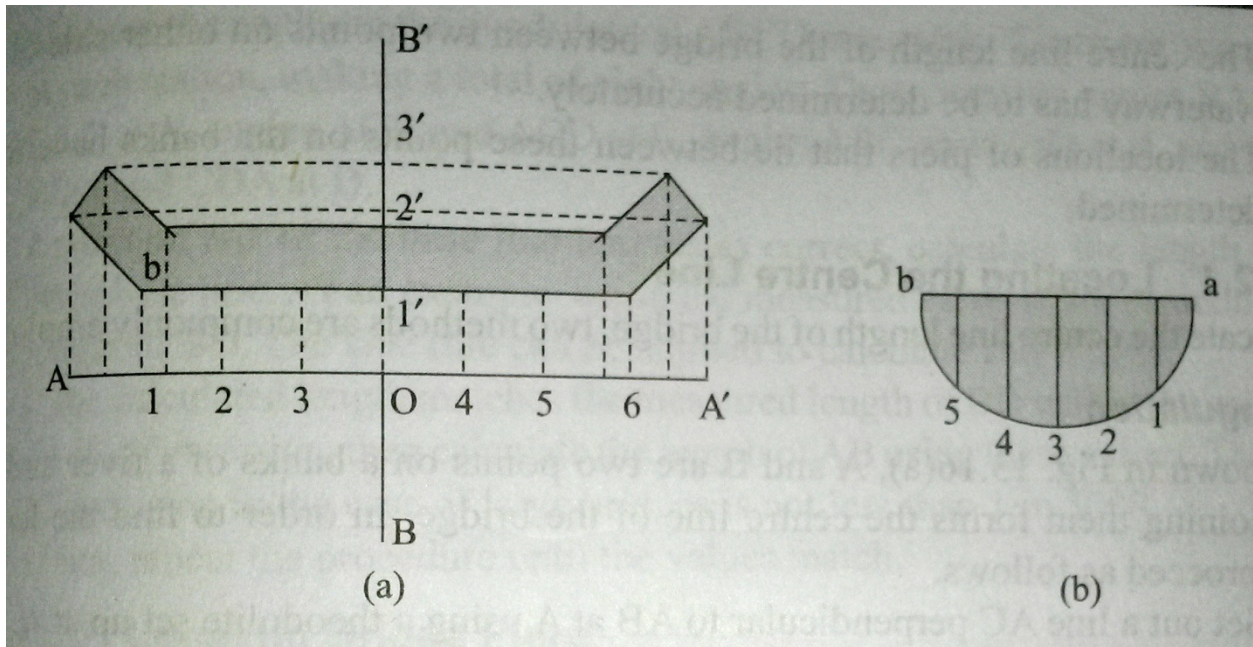

### Setting out a culvert

- Set the points on the foundation lines using coordinates with the help of a tape or by using two theodolite placed at the ends of the lines.
- When using tapes alone, depending upon the length required, connect the two tapes together at their rings. Hold the ends of the tapes at the points on the axes. Set the readings of the coordinates on the tapes. Holding the tape ends at the respective coordinate axes points, pull the tight to locate a point. As an example, to locate a point b, consider 1b and 1'b to be the coordinates. Keep the tape ends at points 1 and 1' respectively, Hold the tapes together at the values of the coordinates. Now pull the tape tightly with help of two individuals holding the tape at points 1 and 1', respectively. In this manner, locate point b. mark the point with a peg and an arrow.
- As an alternative, calculate polar coordinates from 0. Set the angle at the theodolite kept at 0 and measure the distance 'r' with a tape to locate b.
- Once all the points a, b, c, d, etc, are located, tie a string around the points located.
- Make a mark along the string with dry lime powder or make a line by nicking.
- In case any of the walls have a curved outline, locate the end points first. Then locate the curved boundary by using coordinates from the chord of the curve. As shown in fig....

## CHAPTER -8

### 8.0 COMPUTATION OF VOLUME

#### Areas of Cross Sections

The common cross section one comes across in practice are shown in figures. The following symbols will be used to indicate the various parameters of the area.

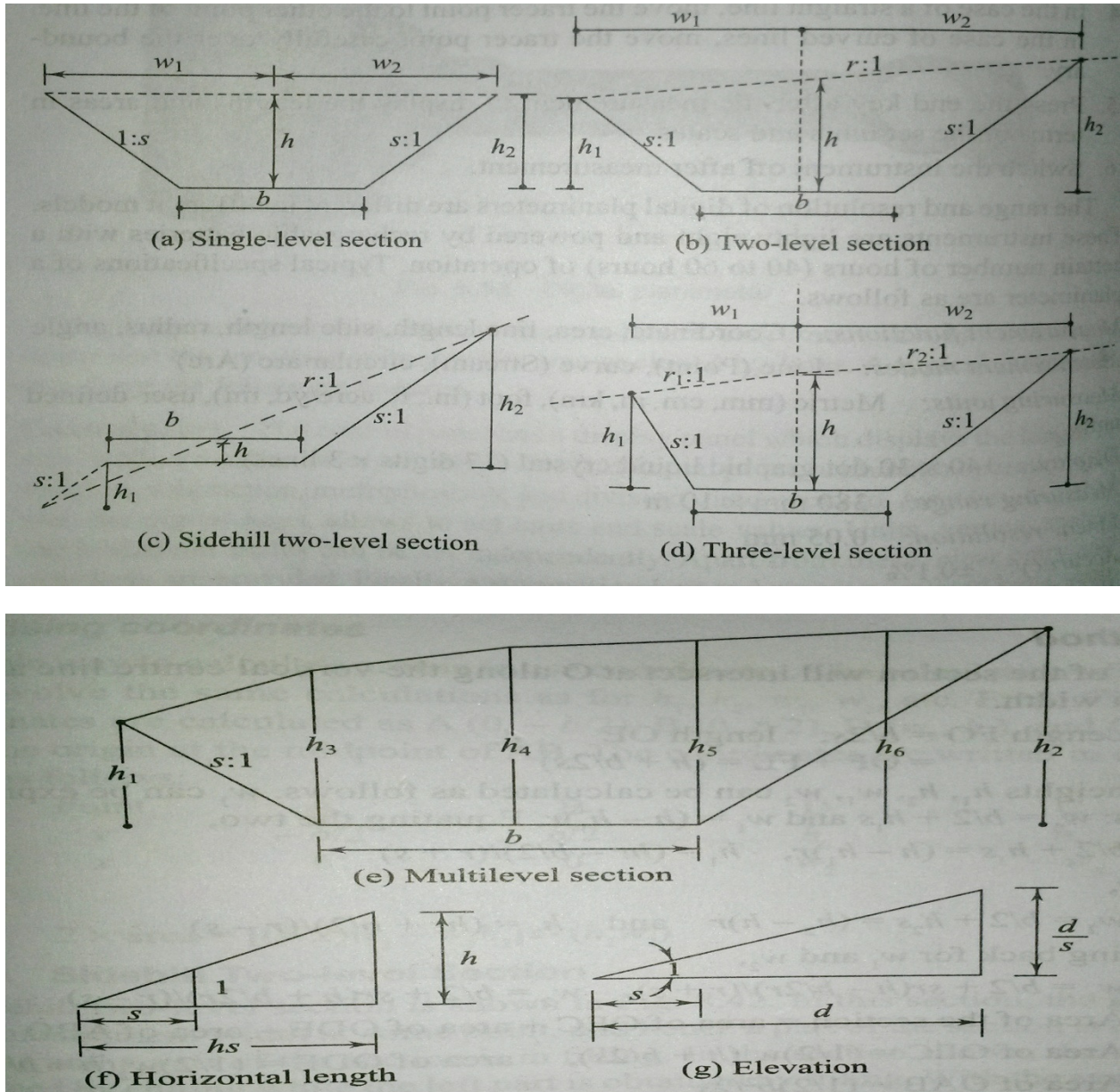

Fig

**Formation width** (width at formation level): It is the width of the sub-grade (b).

**Depth:** It is the depth of cutting or filling at the centre line (h).

Cut being denoted by a plus(+) sign and fil by a minus(-) sign.

**Half-breadth:** This is the horizontal distance from the centre to the intersection of the original ground

with the side slopes ( $d_1$  and  $d_2$ ).

**Side slope:** s to 1 is the side slope, s horizontal to vertical [i.e., the ground rises (or falls) by 1 m over a

horizontal length length of s meters].

**Transverse slope:** n to 1 is the transverse slope of the ground, n horizontal to 1 vertical [ i.e., the ground

rises (or falls) by 1 m over a horizontal length of n metres.

**Side heights:**  $h_1$  and  $h_2$  are the heights from the formation level to the side slope with the ground.

The following points must be clearly understood in dealing with slopes.

If s:1 is the slope given, then for a given height h, the horizontal distance = hs.

If s:1 is the slope given and the horizontal distance is d, then the vertical distance is given by  $d/s$ .

### 8.1 Method of Computation for different types of cross sections:

The area of each of these cross sections can be calculated as follows.

#### Single – level Section

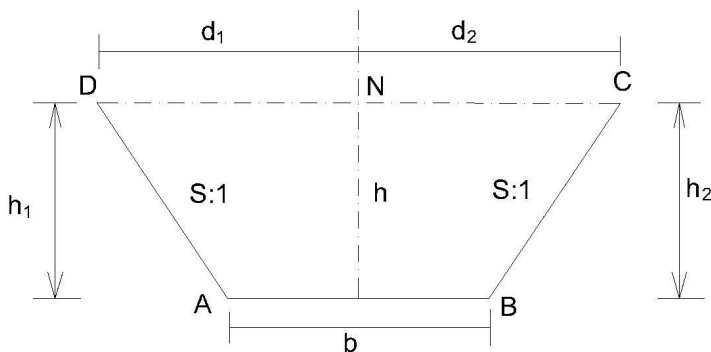

A single – level section may be formed by cutting or filling. In this type cross section the ground is assumed to be level transversely i.e the value of n approach to infinity. In this section, AB is the sub grade of width b,  $d_1$  and  $d_2$  are half-widths – equal in this section, and  $h_1$  and  $h_2$  are end heights – equal to h, the height at midsection. Therefore,  $d_1=d_2= b/2 + sh$ ,  $h_1= h_2=h$ ,

$$\text{Area of the section} = \left(\frac{1}{2}\right) [2 \times \text{half breadth} + b] \times h = \frac{[2\left(\frac{b}{2} + sh\right) + b]}{2} = bh + sh^2$$

### Two-level Section

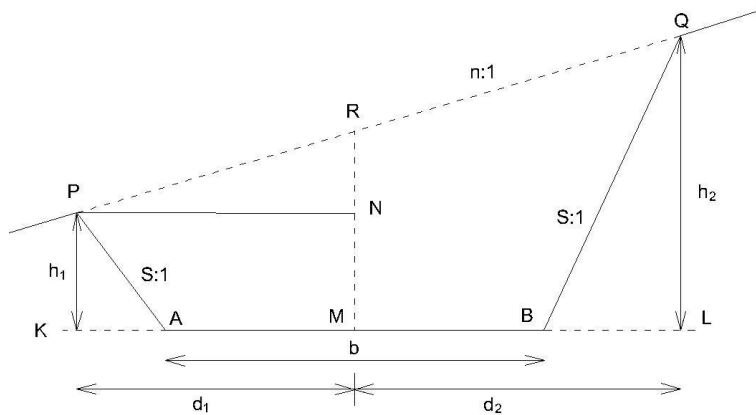

In two level section the top level is not horizontal and the original ground has a slope of  $n:1$ . The two end heights,  $h_1$  and  $h_2$ , are not equal.

$$\text{Area of the cross section} = \frac{d_1 d_2}{s} - \frac{b^2}{4s} \quad \text{Where } d_1 = \left(h + \frac{b}{2s}\right) \left(\frac{ns}{n+s}\right)$$

$$d_2 = \left(h + \frac{b}{2s}\right) \left(\frac{ns}{n-s}\right)$$

### Three Level sections:

Assume that transverse slope of the natural ground is not uniform. Let it be  $n_1$  to 1 and  $n_2$  to 1 on either side of the central line. ( as shown in Fig)

$$\text{Area of the section} = (d_1 + d_2) \left[ \frac{b^2}{4s} + \frac{h}{2} \right] - \frac{b^2}{4s} = \frac{D}{2} \left[ h + \frac{b}{2s} \right] - \frac{b^2}{4s}$$

Where  $D$  is total top width.



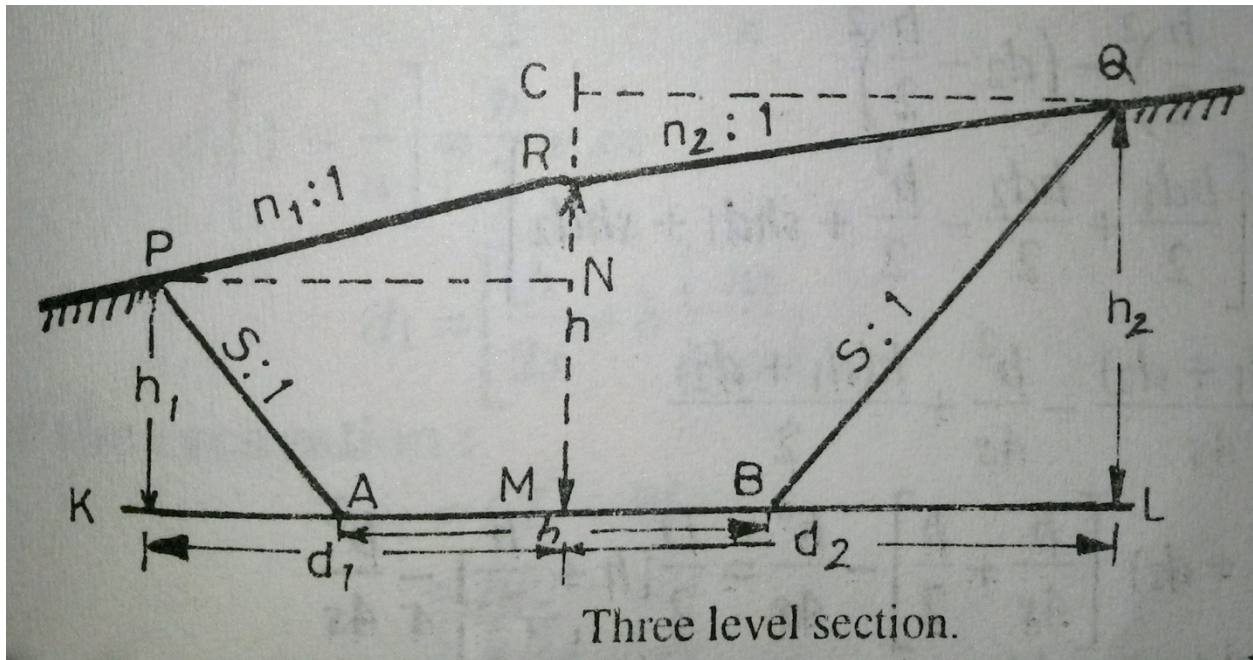

#### 4. Side hill two level section.

In this cases, the ground slopes transversely and the slope of the ground surface cuts the formation level in such a way that one portion of the area is in cutting and the other portion is in embankment i.e. the section consists of two parts one in cutting and the other in filling.

In general two cases may arise.

- (i) When the centre line of the formation is in excavation.
- (ii) When the centre line of the formation is in embankment.

(i) When centre line of the formation is in excavation:

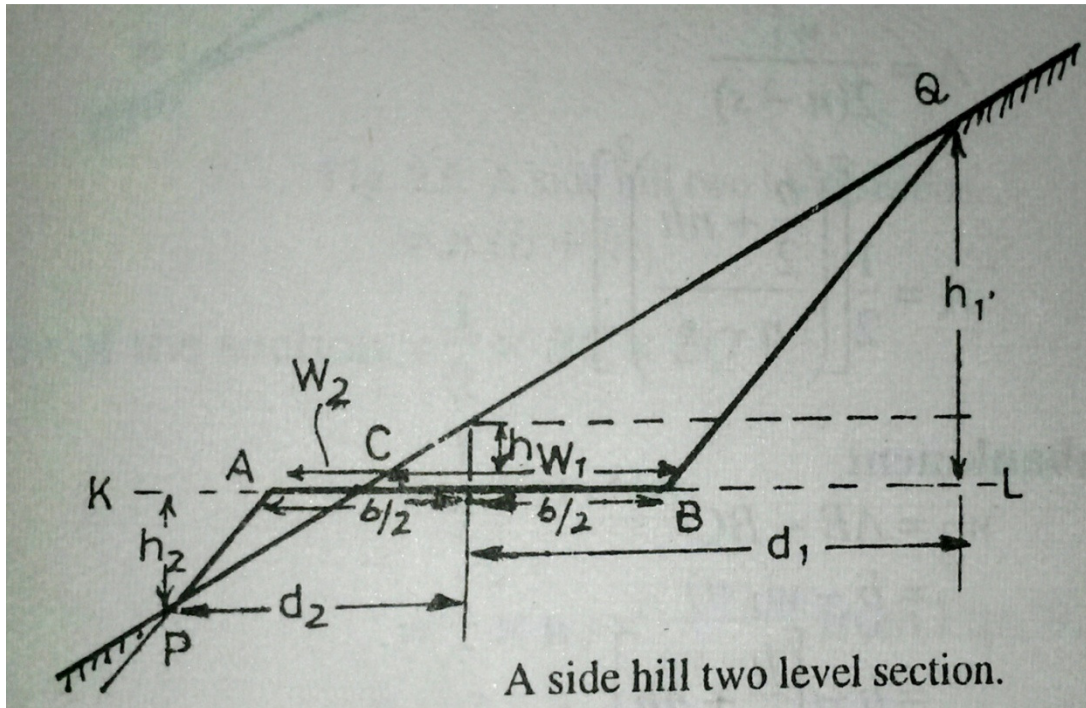

(a) For the excavation :

$$w_1 = CL - BL = nh_1 - sh_1 = h_1(n-s)$$

$$\text{Or } h_1 = \frac{w_1}{n-s}$$

Area in excavation = triangular area BCQ

$$A = \frac{1}{2} \times BC \times QL = \frac{1}{2} \times w_1 \times h_1 = \frac{1}{2} \left[ \left( \frac{b+nh}{n-s} \right)^2 \right]$$

(b) For the embankment

$$W_2 = AB - BC = b - w_1 = b - \left[ \frac{b}{2} + nh \right] = \frac{b}{2} - nh$$

$$\text{And } d_2 = \left( \frac{b}{2s} - h \right) \left( \frac{ns}{n-s} \right)$$

Area in embankment = triangular area ACP

$$= \frac{1}{2} \times w_2 \times h_2$$

$$= \frac{1}{2} \left[ \left( \frac{b-nh}{n-s} \right)^2 \right]$$

(ii) When centre line of the formation is in embankment.

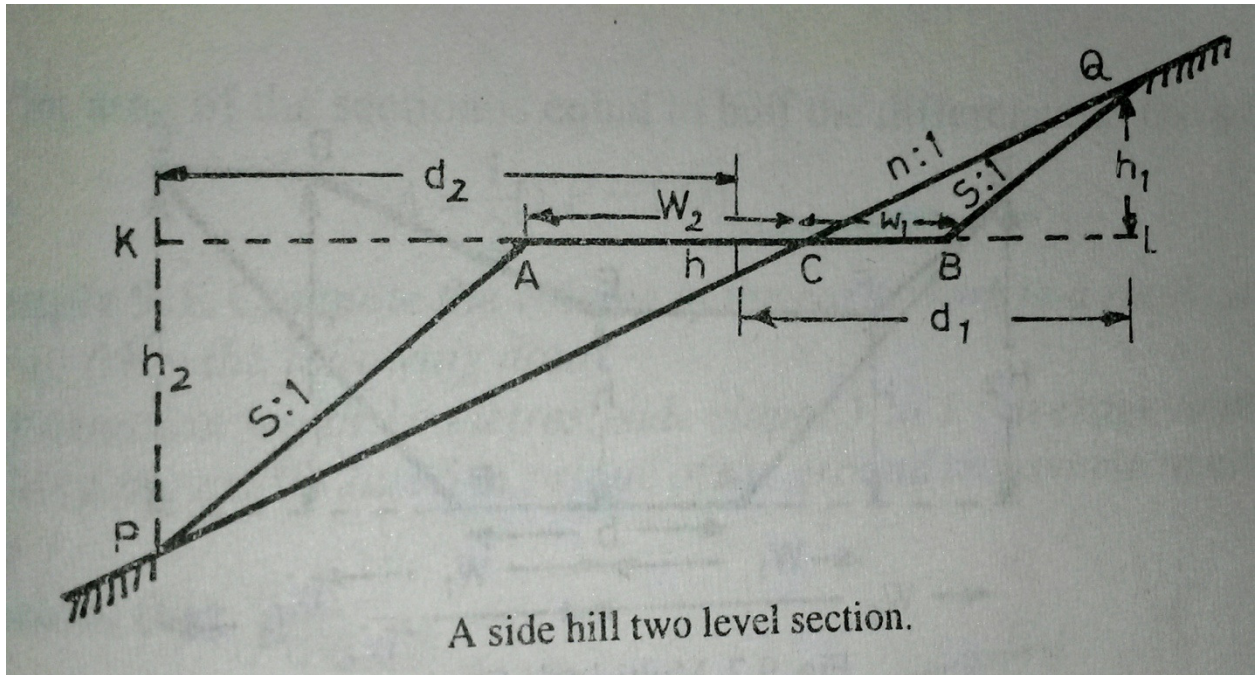

(i) For excavation

$$w_1 = nh_1 - sh_1 = (n-s)h_1$$

$$d_1 = nh_1 + nh$$

$$= n(h + h_1)$$

$$\text{Area of the section} = \frac{1}{2} \times BC \times LQ = \frac{1}{2} \times w_1 \times h_1$$

$$= \frac{(w_1)^2}{2(n-s)}$$

For embankment

$$w_2 = b - w_1$$

$$w_2 = \frac{b}{2} + nh$$

$$d_2 = \frac{b}{2} + sh_2$$

$$\text{Area of the section} = \frac{1}{2} \times w_2 \times h_2$$

$$\text{But } h_2 = \frac{w_2}{n-s}$$

$$A = \frac{(w_2)^2}{2(n-s)}$$

**5. Multi-Level Section :** In this case, spot levels and their distances from the central line, are usually recorded as shown in Table

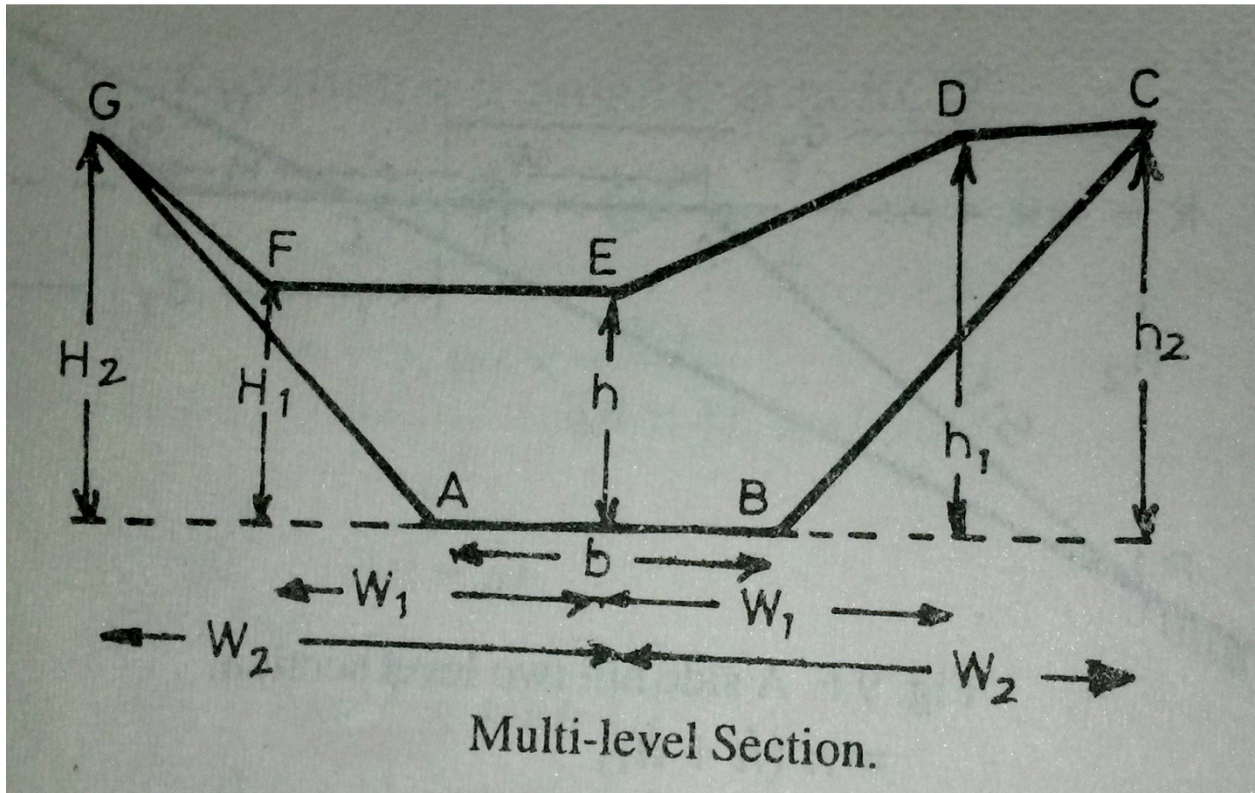

Table

Left		Centre	Right	
$\frac{\pm H_2}{W_2}$	$\frac{\pm H_1}{W_1}$	$\frac{\pm h}{0}$	$\frac{\pm h_1}{W_1}$	$\frac{\pm h_2}{W_2}$

In Table numerators of the fractions denote the amount of cutting (+ve) and filling (-ve) at the various points whereas the denominators denote their horizontal distances from the centre line of the section.

Assuming the formation level  $AB$  as  $x$  axis and  $OE$ , the perpendicular bisector of  $AB$  as the  $Y$  axis, these notes may be considered as  $x$  and  $y$  coordinates of each point of the section. The area of the cross-section may then be computed by the method of coordinates. The points  $A, B, C, D, E, F, G$  may be written irrespective of their signs in the form of a determinant.

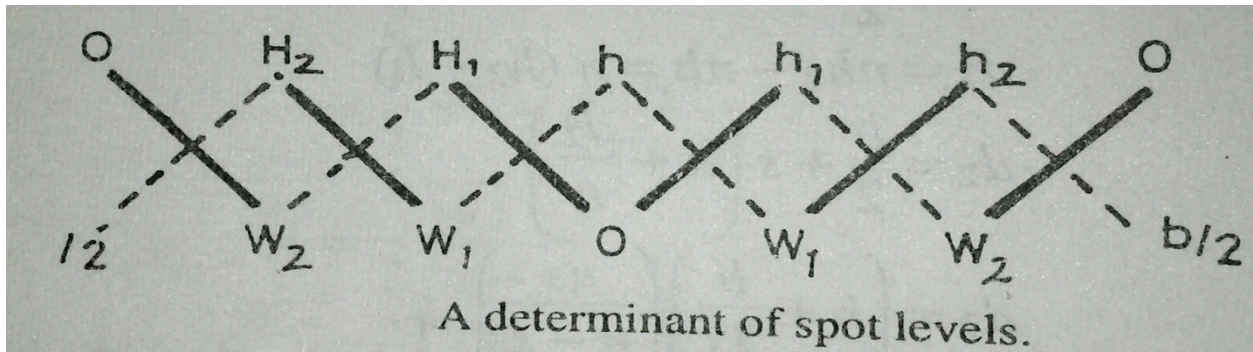

For preparation of the determinant, start from the centre and proceed to the right and to the left.

For calculation of the area, proceed as under :

- (1) Find the sum of the products of the co-ordinates Joined by full lines and denoted by  $\sum F$   
i.e.  $\sum F = OH_1 + W_1H_2 + W_2O + Oh_1 + w_1h_2 + w_2O$
- (2) Find the sum of the products of the coordinates Joined by dotted lines and denoted by  $\sum D$   
i.e.  $\sum D = hW_1 + H_1W_2 + H_2 \frac{b}{2} + hw_1 + h_1w_2 + h_2 \frac{b}{2}$
- (3) The area of the section is equal to half the difference of the sums. i.e.

$$\text{Area} = \frac{1}{2} [ \sum F - \sum D ]$$

**Example 1.** Compute the volume of the earth work in a road cutting 50 metres long from the following data :

The formation width 10 metres; side slopes 1 to 1 ; average depth of the cutting along the centre line 5 m ; slope of the ground transverse to cross-section 10 to 1.

**Solution.** (Fig.9.9)

The cross-sectional area in terms of  $d_1, d_2$  and  $s$  is given by

$$A = \text{Area of the cross section} = \frac{d_1 d_2}{s} - \frac{(b)^2}{4s}$$

$$\text{Where } d_1 = \left( h + \frac{b}{2s} \right) \left( \frac{ns}{n+s} \right)$$

$$d_2 = \left( h + \frac{b}{2s} \right) \left( \frac{ns}{n-s} \right)$$

Here  $h=5m, b=10m, s=1n=10$

hence  $d_1 = \frac{100}{11} m$  and  $d_2 = \frac{100}{9} m$

$$A = \frac{100}{11} \times \frac{100}{9} - \frac{(10)^2}{4 \times 1} = 76.01 \text{ sq.m}$$

The required volume in cutting =  $A \times L = 76.01 \times 50 = 3800.05$  cubic metres

## 8.2 Calculation of volumes:

The volume of the earth work between-cross sections taken along a route, may be calculated by one of the following methods:

1. Prismoidal formula
2. Trapezoidal formula (End area formula)

### 1. Prismoidal formula.

A Prismoid is a solid bounded by planes of which two, . Called end faces, are parallel. The end faces may be both polygons, not necessarily similar or with the same number of sides, one of them may even be a point. The other faces, called the longitudinal faces are planes extending between the end planes.

**Statement of the formula :** “The volume of a prismoid is equal to the sum of the areas of end parallel faces plus four times the area of the central section, and multiplied by 1/6th of the perpendicular distance between the end sections.

Let  $A_1, A_2, A_3, \dots, A_n$  be areas of cross-sections and  $D$  is the distance between consecutive sections.

$$\begin{aligned} \text{Volume ( V )} &= \frac{D}{3} [ A_1 + 4A_2 + 2A_3 + 4A_4 + \dots + A_n ] \\ &= \frac{D}{3} [ A_1 + A_n + 2\sum \text{odds} + 4\sum \text{evens} ] \end{aligned}$$

$$\begin{aligned} &= [\text{area of the first section} + \text{area of the last section} \\ &\quad + 2 \text{ times area of remaining odd sections} \\ &\quad + 4 \text{ times area of remaining even sections}]. \end{aligned}$$

It is sometimes known as the Simpson’s rule for volume.

**Note :** The following points may be noted.

- In order to apply the prismoidal formula for volumes, number of cross-sections should always be odd.
- If there is even number of cross-sections, one of them (preferably the last one) may be treated separately and the volume of the remaining length of the route may be computed by the prismoidal formula.
- The volume of the last section may be calculated by the trapezoidal rule or prismoidal formula.

## 2. Trapezoidal formula(End area formula) :

While calculating volumes by the end area formula , it is assumed that volume of a prismoid, is equal to the product of the length of the prismoid by the average of the end areas.

$$\text{i.e. } V = L \times \frac{A_1 + A_2}{2}$$

where  $V =$  Volume of the prismoid  
 $A_1 =$  Area of one end section  
 $A_2 =$  Area of other end section  
 $L =$  distance between the sections.

For a series of cross sections, the Eqn. may be simplified as

$$V = \frac{L}{2} [ A_1 + 2A_2 + 2A_3 + \dots + 2A_{n-1} + A_n ]$$

$$V = L \left[ \frac{A_1 + A_2}{2} + A_2 + A_3 + \dots + A_{n-1} \right]$$

### Prismoidal Correction:

The volume obtained by the end area formula is not as accurate as obtained by the prismoidal formula. The accuracy of the result obtained by the end area formula may be increased by applying a correction called, the prismoidal correction. As the volume of any prismoid calculated by the end area formula is somewhat larger than that obtained by the prismoidal formula, hence prismoidal correction is always negative.

Prismoidal Correction (P.C.)

= volume by the end area formula – volume by the prismoidal formula.

$$\text{i.e. } P.C. = \frac{L}{2} (A_1 + A_2) - \frac{L}{6} (A_1 + 4A_m + A_2) = \frac{L}{3} (A_1 + A_2 - 2A_m)$$

$$\text{where } A_1 = (b + sh_1)h_1, A_2 = (b + sh_2)h_2, A_m = \left[ b + \frac{s(h_1 + h_2)}{2} \right] \left( \frac{h_1 + h_2}{2} \right)$$

substituting the values

$$P.C. = \frac{L}{6} s(h_1 - h_2)^2$$

### Curvature correction for volumes:

The formulae obtained for the earth work calculation are based on the assumptions that the sections are parallel to each other and normal to the centre line. But, on curves the cross-sections are run in radial lines and consequently the earth solids between them do not have parallel faces. Therefore, the volumes computed by the usual methods, assuming the end faces parallel, require a correction for the curvature of the central line. The calculation of the volumes along the curved line is made by the Pappu's theorem.

**Pappu's Theorem.** It states that the volume swept by a constant area rotating about a fixed axis is equal to the product of that area and the length of the path traced by the centroid of the area."

Let  $e_1$  = distance of centroid of area A1 from the centre line.

$e_2$  = distance of centroid of area A2 from the centre line.

= mean distance of the areas A1 and A2 from the centre line.

L= distance between two curved centre lines.

R= radius of the curved central line

Applying Pappu's theorem of volume,

$$\text{The Curvature correction} = \left( \frac{d_2 - d_1}{2} \right) \left( h + \frac{b}{2s} \right) (d_2 + d_1) \frac{L}{3R}$$

The correction is positive or negative according to whether greater half breadth is on the convex or concave side of the curves.

The following points may be noted :

- The Equation for the curvature correction is applicable on the station on the curve and for each tangent point with the station, half the station correction is applied.
- The formula for a three level section is equally applicable to a two level section.
- The curvature correction for a level section is zero
- The curvature correction for the cutting in a side hill two level section is  $\frac{Lwh}{6R} (d + b - w)$

### 8.3 Measurement of Volumes from Spot Levels:

- Whenever earth work is required for large excavations, the site is divided into triangles, squares or rectangles of equal area of convenient size.
- The depths of cuttings at the corners of these geometrical figures are obtained by finding the difference in levels between the original and proposed ground surfaces.
- These differences in level may be regarded as the length of the sides of a number of vertical truncated prisms of which areas of horizontal base are known.

The volume of each prism may be obtained by the product of the area of the right section multiplied by the average height of the vertical edges.



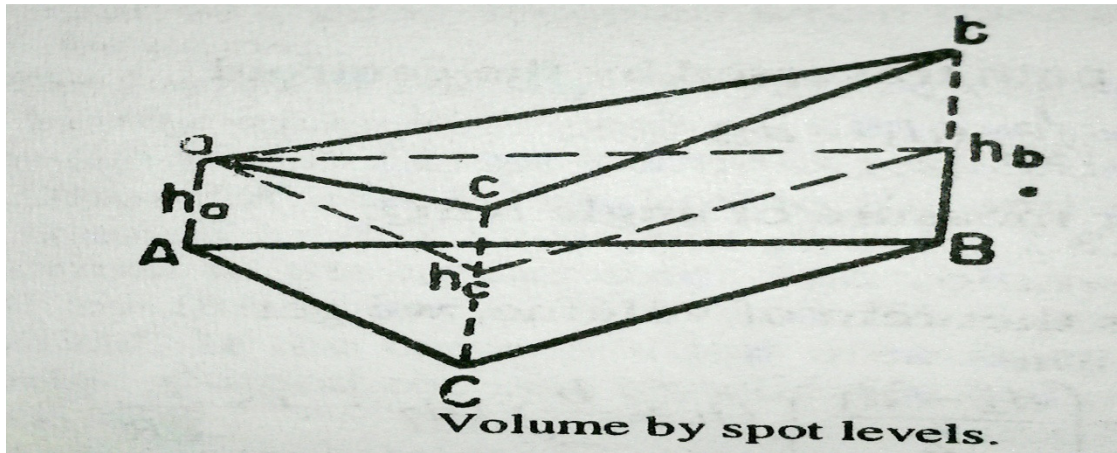

The volume of the truncated triangular prism.

$$= A \left( \frac{h_a + h_b + h_c}{3} \right)$$

and similarly the volume of a truncated rectangular prism

$$= A \left( \frac{h_a + h_b + h_c + h_d}{4} \right)$$

Total volume of any excavation which may consist of a number of prisms, having the same cross-section, may be computed as follow.

- (1) Multiply each corner height by the number of times it is used i.e. the number of prisms in which it occurs.
- (2) Add the products and divide the sum by 4.

i.e. 
$$H = \left( \frac{\sum h_1 + 2\sum h_2 + 3\sum h_3 + 4\sum h_4}{4} \right)$$

where  $\sum h_1$  = sum of the heights used once.

$\sum h_2$  = sum of the heights used twice.

$\sum h_3$  = sum of the heights used thrice.

$\sum h_4$  = sum of the heights used four times.

- (3) The total volume  $V =$  horizontal area of the cross-section of one prism  $\times H$ .

i.e.  $V = A \times H$

### Calculation of reservoir capacities:

- The capacity of a reservoir may be easily found out with the help of a contour map.
- The area enclosed by each contour line is measured by a planimeter
- When the finished surface of the ground is horizontal, it becomes parallel to the surface defined by the contour line
- The area bounded by each contour will be treated as the area of the cross-sections and the vertical contour interval will be taken as the distance between the adjacent cross-sections
- Calculation of the volume may be done either by the Prismoidal formula or by the Trapezoidal formula
- Cubic contents between successive contours when added together give the required capacity of the reservoir
- While applying the prismoidal formula, every second contour area is treated as the area of mid-section,

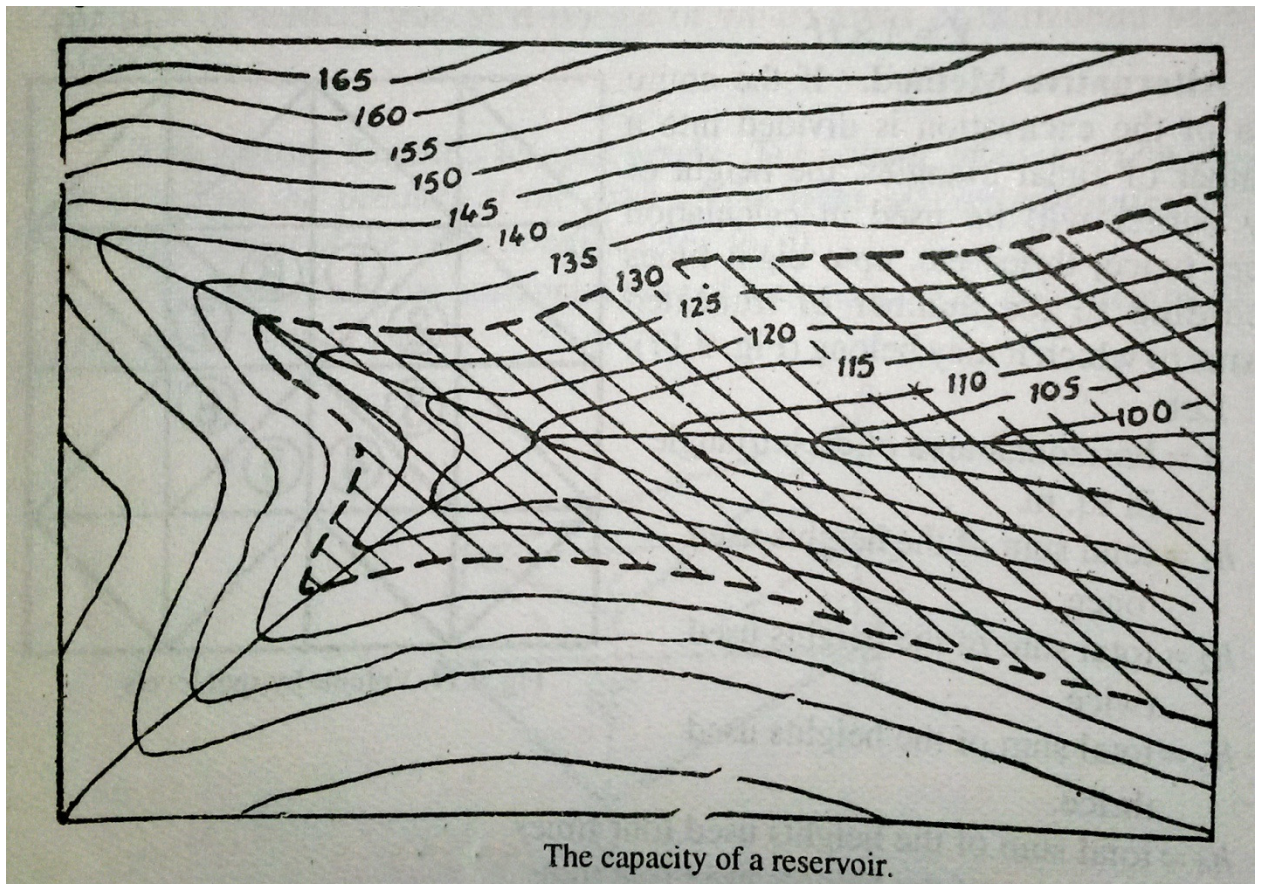

**Trapezoidal formula :**

$$V = L \left[ \frac{A_1 + A_2}{2} + A_2 + A_3 + \dots + A_{n-1} \right]$$

**Prismoidal formula :**

$$V = \frac{D}{3} [ A_1 + A_n + 2\sum \text{odds} + 4\sum \text{evens} ]$$

**Example** A road embankment is 30 metre wide at the top with side slopes of 2 to 1. The ground levels at 100 metre intervals along line PQ are as under :

P 153.0 ; 151.8 ; 151.2 ; 150.6 ; 149.2 Q

The formation level at P is 161.4 m with a uniform falling gradient of 1 in 50 from P to Q. Calculate by prismatic formula the volume of earth work in cubic metres, assuming the ground to be level in cross-section.

(U.P.S.C. Engg. Services, Exam. 1969)

**Solution.**

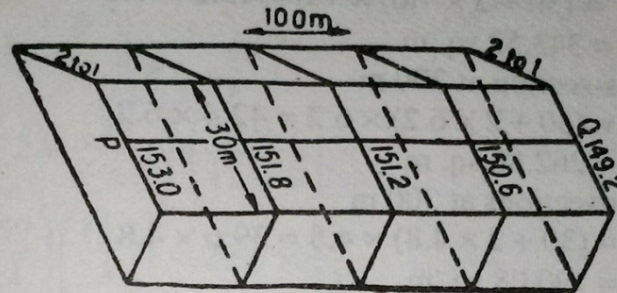

The formation level at  $p = 161.4$  m.

Uniform falling gradient is 1 in 50 from P to Q.

$\therefore$  The formation levels at successive cross-sections are obtained by deducting  $\frac{1}{50} \times 100 = 2$  m from the level of preceding section.

The formation level at P, 0 m = 161.4 m

The formation level at 100 m = 159.4 m

The formation level at 200 m = 157.4 m

The formation level at 300 m = 155.4 m

The formation level at 400 m = 153.4 m

The depths of the embankment at various sections = Formation level - Ground level, *i.e.*

The depth at P, 0 m  $161.4 - 153.0 = 8.4$  m.

The depth at 100 m  $= 159.4 - 151.8 = 7.6$  m

The depth at 200 m  $= 157.4 - 151.2 = 6.2$  m

The depth at 300 m  $= 155.4 - 150.6 = 4.8$  m

The depth at Q, 400 m  $= 153.4 - 149.2 = 4.2$  m

(i) Area of cross-section at P, 0 m. (Fig. 9.20)

$$\begin{aligned} A_0 &= (b + sh) h \\ &= (30 + 2 \times 8.4) \times 8.4 \\ &= 46.8 \times 8.4 \\ &= 393.12 \text{ sq. m} \end{aligned}$$

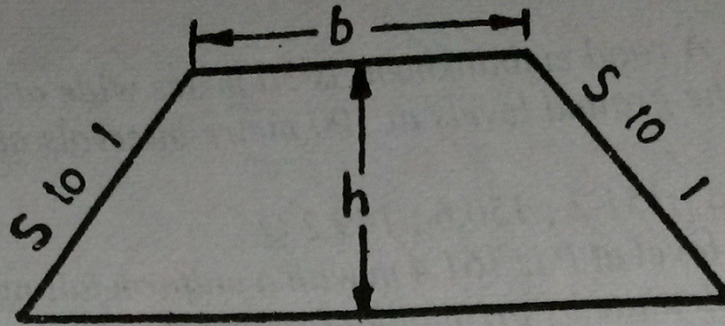

(ii) Area of cross-section at 100 m

$$A_{100} = (b + sh)h = (30 + 2 \times 7.6) \times 7.6 = 45.2 \times 7.6 \\ = 343.52 \text{ sq. m}$$

(iii) Area of cross-section at 200 m

$$A_{200} = (b + sh)h = (30 + 2 \times 6.2) \times 6.2 = 42.4 \times 6.2 \\ = 262.88 \text{ sq. m}$$

(iv) Area of cross-sections at 300 m

$$A_{300} = (b + sh)h = (30 + 2 \times 4.8) \times 4.8 = 39.6 \times 4.8 \\ = 190.08 \text{ sq. m}$$

(v) Area of cross-section at 400 m

$$A_{400} = (b + sh)h = (30 + 2 \times 4.2) \times 4.2 = 38.4 \times 4.2 \\ = 161.28 \text{ sq. m}$$

Applying the Prismoidal formula, we get

$$V = \frac{d}{3} [\text{Area of first section} + 4 \text{ times area of even sections.} \\ + 2 \text{ times area of odd sections} + \text{Area of last section}] \\ = \frac{100}{3} [393.12 + 2 \times 262.88 + 4 (343.52 + 190.08) + 161.28] \\ = \frac{100}{3} [393.12 + 525.76 + 2134.4 + 161.28] \\ = 107152 \text{ cubic metres Ans.}$$

**Example** A railway embankment is 9 m wide at formation level, with side slope of 2 to 1. Assuming the ground to be level transversely, calculate the volume of the embankment in cubic metres in a length of 180 m, the centre heights at 30 m intervals being 0.6, 0.8, 1.5, 1.8, 0.75, 0.3 and 0.67 m respectively. Use Trapezoidal method.

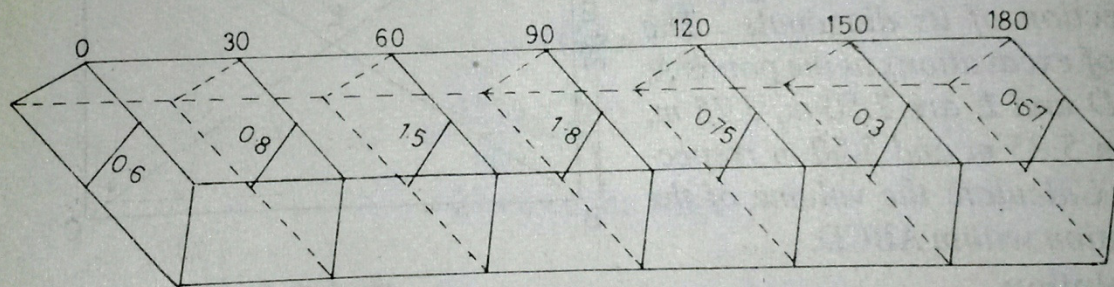

1. Area of cross section at 0 m  $= (b + sh) h$   
 $= (9 + 2 \times 0.6) 0.6 = 6.12 \text{ m}^2$
2. Area of Cross section at 30 m  $= (9 + 2 \times 0.8) 0.8 = 8.48 \text{ m}^2$
3. Area of Cross section at 60 m  $= (9 + 2 \times 1.5) 1.5 = 18.0 \text{ m}^2$

4. Area of Cross section at 90 m =  $(9 + 2 \times 1.8)1.8 = 22.68 \text{ m}^2$   
 5. Area of Cross section at 120 m =  $(9 + 2 \times 0.75) 0.75 = 7.875 \text{ m}^2$   
 6. Area of Cross section at 150 m =  $(9 + 2 \times 0.3) 0.3 = 2.88 \text{ m}^2$   
 7. Area of Cross section at 180 m =  $(9 + 2 \times 0.67)0.67 = 6.928 \text{ m}^2$

∴ Volume of the embankment by Trapezoidal method.

$$V = h \left[ \frac{A_1 + A_n}{2} + A_2 + A_3 + A_4 + \dots + A_{n-1} \right]$$

$$= 30 \left[ \frac{6.12 + 6.928}{2} + 8.48 + 18.0 + 22.68 + 7.88 + 2.88 \right]$$

$$= 1993.35 \text{ m}^3 \quad \text{Ans.}$$

#### 8.4 Mass Diagram:

- Mass haul diagram used for ascertaining in advance, proper distribution of excavated material and the amount of waste and borrow required for the estimation of cost.,
- It is a curve plotted on a distance base, the ordinate at any point of which represents the algebraic sum of the volumes of cuttings and fillings from the starting point of the earth work to that point.
- In plotting a mass diagram, cuttings are assumed as positive and the fillings as negative.
- If cuttings and fillings are on the same length of the longitudinal section, as in hill side road, their difference only is used in the algebraic summations, the sign of the greater volume is accepted in the computation.

The definitions of important terms are listed below.

1. **Haul distance.** It is the distance at any time between the working face of an excavation and the tip end of the embankment formed from the hauled material.
2. **Average haul distance.** It is the distance between the centre to gravity of a cutting and center of gravity of filling.

3. **Haul.** . It is the sum of the products of the each volume by its haul distance i.e  $\sum v . d = VD$ , where V is the total volume of an excavation and D is the average haul distance.
4. **Free haul distance.** It is the specified distance in terms of contracts, up to which the excavated material, is transported regardless to the haul distance.
5. **Over haul distance.** If the excavated material from a cutting has to be moved to a greater distance than the free haul distance, the extra distance is known as over haul distance.
6. **Balancing line.** Any horizontal line drawn on the curve balances the volumes of cutting and filling because, there is no difference in aggregate volume between the two points, such a line is known as, a balancing line, i.e MN in Fig

### Construction of a Mass Diagram

The following steps are followed for the construction of a Mass Diagram:

- Divide the length of the road or railway in separate sections of convenient distances.
- Calculate the volumes of the earth work for each section.
- Plot a longitudinal section of each section of the road on a convenient scale.
- Plot the volumes as ordinates and distances between the sections which are kept same, as the longitudinal section.
- Plot the positive volumes above the base line and the negative volumes below the base line.
- Join the ends of the adjacent ordinates by a smooth curve to obtain the required mass diagram.

### Characteristic of a Mass Diagram

- If the slope of the curve in the direction of the increasing abscissa is upward, it indicates an excavated section.
- If the slope of the curve in the direction of the increasing abscissa is downward it indicates an embankment.
- The vertical distance between a maximum ordinate and the next forward minimum ordinate represents the whole volume of a filling.
- The vertical distance between a minimum ordinate and thenext forward maximum ordinate, represents the whole volume of a cutting.
- The vertical distance between two points on the curve which has neither a maximum nor a minimum point, represents the volume of earth work between their abscissa i.e. the changes.
- If the mass diagram curve cuts the base line at any two points in succession then, the volume of cutting equals that of filling between these points, since the algebraic sum of the quantity between such points, is zero.
- Any horizontal line MN drawn parallel to the base line and intersecting the curve at two points, indicates a length over which the volumes of cutting and filling will be equalized.



- When the loop of the curve cut off by a balancing line, the direction of haul must be backward.
- The length of a balancing line intercepted by a loop of the curve is equal to the maximum distance involved in disposing off the excavation. In Fig. 9.30, the haul distance for the loop MN is mn, where MN is the balancing line. The haul distance increases from zero at m to a maximum at point n.
- The area enclosed by a loop of the curve and a balancing line, measures the haul in that direction.
- The haul over any length is a maximum when the balancing line is so situated that the sum of all areas cut off by it, ignoring the sign, is a minimum.

**Use of mass diagram:**

The mass haul diagram is used for the following purpose

- To find out an economical scheme for distributing the excavated material by comparing a number of balancing lines drawn on the curve.
- To avoid the wastage of the material at one place and borrowing at another place.
- To overcome the difficulty of estimates of the proposed wastage the designer may advise widening an embankment or a cutting where necessary.
- To know the cost of excavation and balancing one cubic metre as compared to balancing to waste one cubic metre plus that of excavating and hauling one cubic metre from the borrow pits.

**Example** Draw a mass diagram for a road 590 meters in length. The detail of the earth work involved is tabulated here under.

Distance (meters)	Cutting (+)	Filling (-)	Total Volume (cubic meters)
0		140	0
40	140		-140
80	130		0.0
120			+130
160		100	30
200		140	-110
240	80		-30
280	230		+200
320	170		+370
360	180		+450
400		150	+300
440		140	+160
480	50		+210
520	130		+340

560  
590

210

20

+550  
+530

Solution

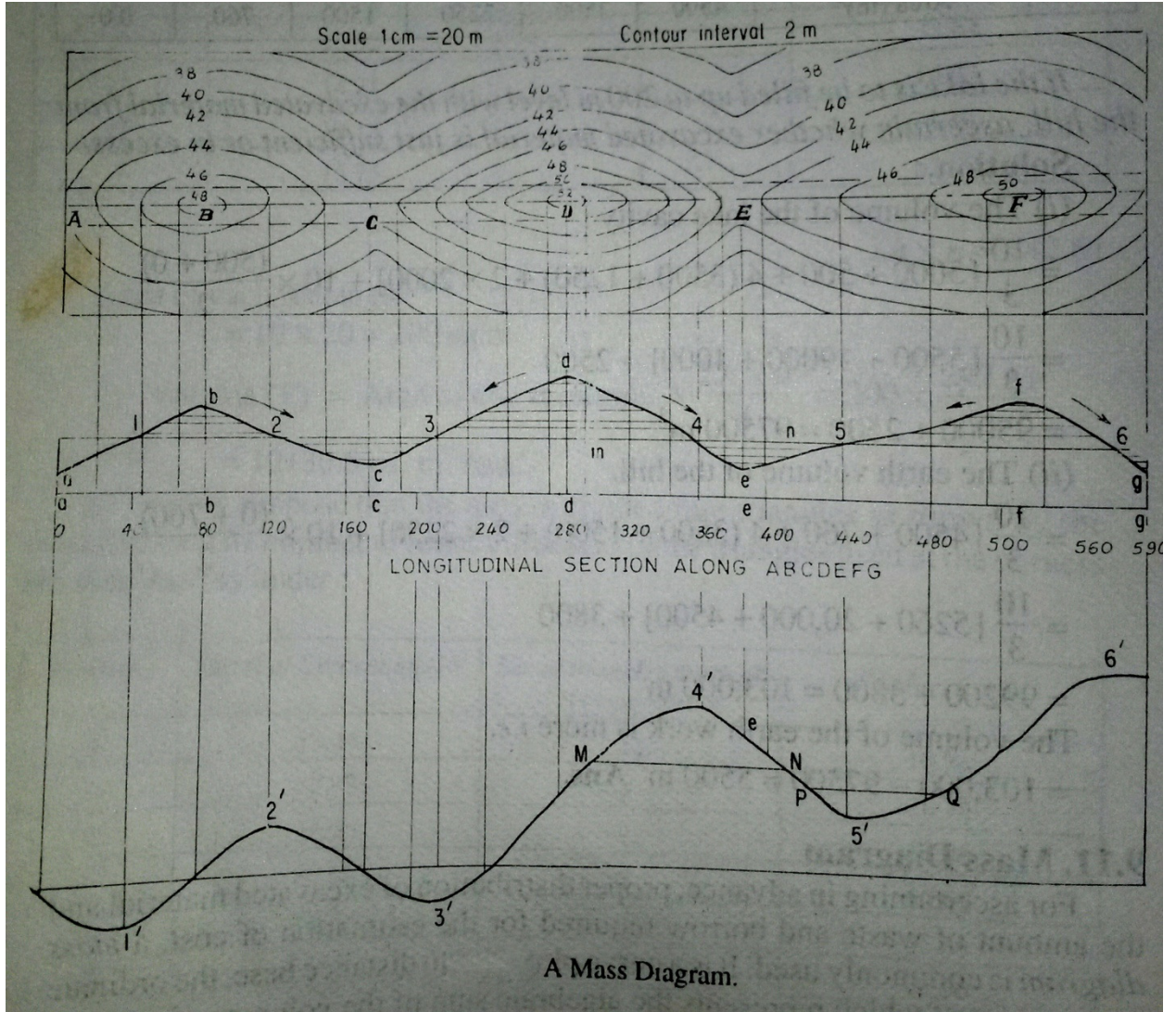

## CHAPTER-9

### 9.1 Micro-optic Theodolites :-

Micro-optic theodolites can read angles to an accuracy of  $10''$  or even less. The essential principle is illustrated in Fig.9.1. The special features of such theodolites are as follows.

- (a) Conventional metal circles are replaced by glass circles on which the graduations are etched by photographic methods. The graduations can be made finer and sharper by this technique. Both the horizontal and vertical circles are made of glass and generally graduated to  $10'$ .
- (b) Light passing through the circle at the point of the reading is taken through a set of prisms to the field of view of the observer. For passing light through glass circles, sunlight is reflected through a reflecting prism and passed through the circle. In case night operation is required, the battery-operated light provided in the instrument can be used.
- (c) Both the horizontal and vertical circles are seen at the same in the field of view. This is an advantage, as the readings of both the circles can be taken at the same time. Some manufacturers make a switching arrangement so that the horizontal or vertical circle reading can be seen along with the micrometer reading.
- (d) The optical micrometer is used to read fractions of the main scale division. Depending upon the reading system, angles can be read up to  $10'$  or less.
- (e) The circles are generally graduated to  $10'$  or  $20'$  of the arc. The micrometer can be read after coinciding the index with the nearest main scale division. The fractions are then read from the micrometer scale, which is also seen in the field of view.
- (f) A small, separate reading telescope is provided besides the main telescope. It eliminates the need to move while bisecting an object and taking the reading.
- (g) In most instruments, diametrically opposite ends of the circle are brought together in the field of view.

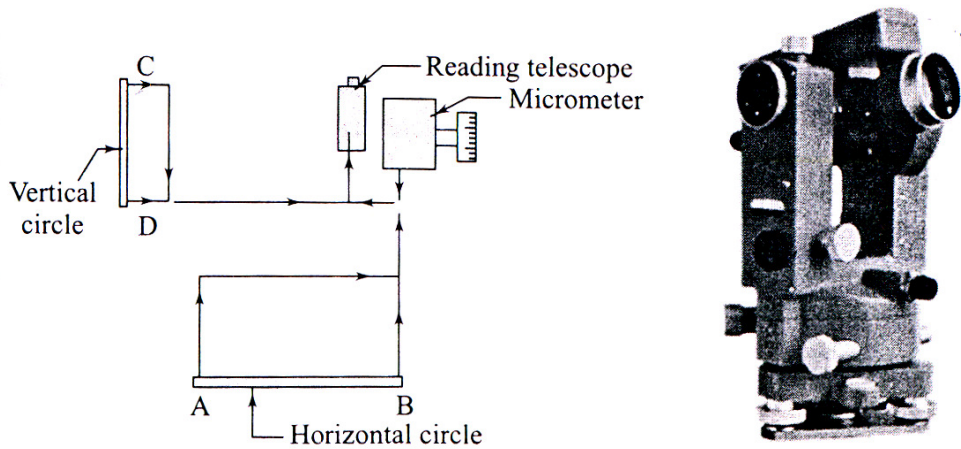

Fig.9.1

**Digital theodolites:-**

Digital theodolites are very fine instruments for angle and distance measurements. The instruments are light weight and are similar to electronic theodolites in construction.

The instrument is set up over a station as in the case of normal theodolites. They will have extendable tripod legs which can be adjusted for comfortable viewing. The centering and leveling operations are done with a circular vial for coarse setting one has to press only a measure button to get the readings of angles and distances. Some models also have a laser pointer for easy alignment in critical cases and for staking out operations. With the arrival of total stations, these theodolites have less demand though they are cheaper compared to a total station.

The following are typical features in a digital theodolite:

- Angle measurement – by absolute encoding glass circle;  
Diameter – 71 mm
- Horizontal angle- 2 sides; vertical angle – one side;  
Minimum reading – 1”/5”
- Telescope – Magnification – 30x; Length – 152 mm;  
objective lens – 45 mm

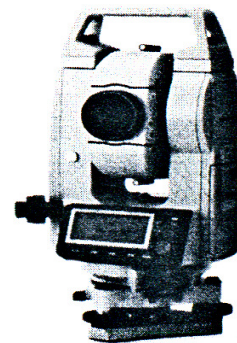

Fig.9.2

- Field of view -  $1^{\circ}30'$  Minimum focus distance – 1m
- Stadia values: Multiplying constant – 100; additive constant-0
- Laser pointer – coaxial with telescope; 633 nm class II laser; Method – focusing for alignment and stake out operations.
- Display on both sides; 7-segment LCD unit
- Display and reticle illuminated
- Compensator- tilt sensor; vertical tilt sensitivity +  $3'$
- Optical plummet – magnification – 3x; field of view -  $3^{\circ}$ ; focusing from 0.5 m to infinity
- Level sensitivity – Plate vial –  $40''/2\text{mm}$ ; circular vial –  $10'/2\text{mm}$
- Power supply – 4 AA size batteries; Operating times – Theodolite only – 140 hours
- Laser only – 80 hours; Theodolite + laser – 45 hours
- Weight – 4.2 kg.

**(ii) Electronic Distance Meter (EDM):**

EDM equipment can be classified based upon the type of wave used, into M (microwave) DM and EO (electro-optical) DM equipment. The first type uses low-frequency short radio waves while the second type uses high-frequency light waves. They can also be classified based upon the range as follows.

- (a) Short-range equipment such as teleprompters and theodolites with a range of up to 3 km.
- (b) Medium-range equipment such as geodimeters with a range of up to 25 km. The range is about 5 km during the day and can go up to 25 km at night.
- (c) High – range equipment with a range of up to 150 km. Tellurometers and distometers come under this category.

The accuracy varies with the range. Short-range equipment has an accuracy of  $\pm (0.2 \text{ mm}) + 1 \text{ mm/km}$ . Medium-range equipment has an accuracy of  $\pm (5 \text{ mm} + 1 \text{ mm/km})$  while high-range equipment has an accuracy of  $\pm (10 \text{ m} + 3 \text{ mm/km})$ . Distometers have replaced other forms of equipment due to their compact design, ease of operation, and precision.

All types of equipment using electromagnetic waves perform the following functions.

- (a) Generation of two waveforms for carrier and measurement functions.
- (b) Modulation and demodulation of waves.
- (c) Measurement of phase difference.
- (d) Computation and display of distance or the results of measurement.

## **8.2 Total Stations**

One of the recent developments in surveying equipment is the integration of distance- and angle-measuring components in one piece of equipment. A total station is the integration of an electronic theodolite with the EDM equipment. Many companies market total stations. Though the technology details used by different manufacturers may be different, they all have common features, which will be discussed below.

A digital theodolite is combined with one of the many forms of EDM equipment to obtain a very versatile instrument that can perform the required functions very easily.

### **Digital Theodolite:**

The electronic or digital theodolite was discussed in Chapter 4. We will just recapitulate some salient points. These instruments have glass circles, which are encoded in the incremental or absolute mode. These are read by an optical scanning system and the reading is converted into angles and displayed or stored by the instrument. All the instruments are provided with an optical plummet for centering and a compensator system (single-axis or dual-axis) to take care of the tilt of the and the displayed angles and distances are previously corrected for such minor errors. The user can choose the required accuracy of angular measurement. These theodolites are normally operated by a rechargeable battery pack. The charged batteries can work for 40-80 hours. Some instruments need a prisms. Even reflecting tapes are used. A digital theodolite comes with the following facilities.

- (a) Zero-setting
- (b) Bidirectional measurement
- (c) Precision setting
- (d) Horizontal and vertical angles
- (e) Slant distance and horizontal distance

- (f) Difference in elevations
- (g) Entry and display of data
- (h) Display and storage of result
- (i) Data management system and data transfer facility

A total station has all the above facilities and in addition measures horizontal distance using a built-in EDM module. Total stations come with a lot more facilities of data storage and manipulation. The following are the salient features of a total station.

**Angle measurement:-** Horizontal and vertical angles are measured to an accuracy of  $1''-5''$ . The angles are displayed on the display unit of the console. Many instruments have console units on both sides of the instrument.

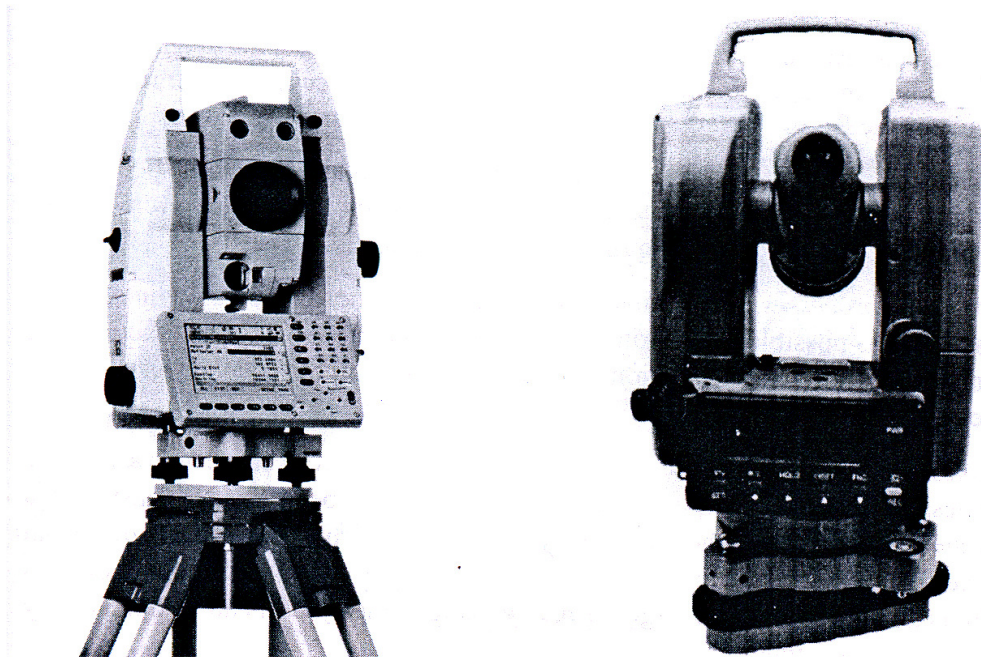

Fig.9.3

**Distance measurement:-** This is done with an EDM module functioning coaxially with the telescope tube. The distance measured is the slant distance if the stations are at different elevations. Reflecting multiple prisms are commonly used as targets, even though reflectorless distance measurement has also been made possible. The instrument uses the vertical angle measured by the theodolite and calculates the horizontal distance measurement can be done in different modes such as standard or coarse mode, precision mode, and fast mode, and fast mode. The precision and time taken vary depending upon the mode.

**Microprocessor and software:-** The onboard software in total stations can perform many functions. The processor is pre-programmed, and in some cases can be programmed by the user to perform many useful functions with the measured data. The details may vary with the manufacturers but some of the common features are as follows.

**Automatic target recognition:-** Most of the modern total stations have the facility of automatic target recognition (ATR). In ATR, the telescope has to be roughly pointed towards the target while the measurement key is pressed. The instrument automatically points to the target before measurement. The instruments have motorized endless drives to facilitate ATR.

**Reflectorless distance measurement:-** Until recently, total stations had to be used with special multiple prisms as targets for EDM. The new versions of total stations can measure distances without a prism target. This means that distances to points where a target cannot be erected can now be measured easily without any extra survey effort. This has been made possible by a red laser, which can direct to a point on any surface.

**Computation of reduced levels:-** The reduced levels are measured from slope distance and vertical angle. Data input enables the user to input the height of instrument, height of target prism, and the RL of the station occupied. The instrument calculates the RL of the target station and displays the same.

**Orientation:-** The instrument automatically orients to any direction specified by the user. If the coordinates of two points are input, the horizontal circle will be oriented to measure the bearing of the line automatically.



**Automated processes:-** Automatic computation of coordinates of points, areas, offsets, etc. is possible with a total station. More and more on-board functions are being incorporated in total stations. Setting out points on the ground using coordinates or directions is possible.

**Wireless keyboard and remote unit:-** Many new total stations come with a separate wireless keyboard. The input of data to the station becomes very easy with a handheld keyboard. Another development is the availability of a remote unit so that the person at the prism can operate the total station for almost all the functions. As there is no need to bisect a target or read the angle, the system can be operated by one person positioned near the target.

**Data management system:-** Total stations have a very efficient data management system. Data transfer to data recorders, computers, or flash cards is possible. The in-built memory can store up to 10,000 blocks of data.

**Graphic display:-** Many new instruments have extremely powerful graphic display programmes. With large display panels, the data can be plotted and displayed.

#### **Working with total station:-**

Total stations are manufactured by many leading manufacturers of Survey equipment. Leica geosolutions, Topcon, Pentax, Nikon tripod data systems, Stonex are some of the major manufacturers of total stations. While specific details may vary with the manufacturers, some features are common to all of them.

A total station, as mentioned earlier, is a versatile equipment for surveying operations. The equipment details and operations can be understood by referring to the user manual provided with the equipment.

### **8.3 Aerial Surveying**

The procedure for aerial surveying includes reconnaissance of the area, establishing ground controls, flight planning, photography, and then paperwork including computation and plotting.

Reconnaissance is undertaken to study the important features of the ground for reference purposes. Ground control is required in order to obtain a set of points known position based on

which other points are located and plotted. The number of ground control points depends upon the extent of area covered, scale of the map to be prepared, flight plan, and the process of preparing the maps. A minimum of three control points must appear in each photograph. These points are established by triangulation or precise traversing.

Flight control is achieved by flight planning, which takes into account the extent of the area, type of camera and its focal length, scale of the photographs, altitude speed of aircraft, and the overlaps of the photograph. The area covered by each photograph. Time interval between exposures and the number of photographs quired are decided based upon such flight planning.

**Stereoscopes:-**

There are many types of stereoscopes- mirror stereoscope, lens stereoscopes, scanning mirror and zoom stereoscopes. Lens and mirror stereoscopes are handy and commonly used.

**Mirror stereoscope :-**The schematic diagram of the mirror stereoscope is shown in fig.9.4 (a). The mirror stereoscope consists of two viewing eyepieces. A stereoscopic pair of photographs is placed at a distance from the stereoscope. The photographs are adjusted so that one photograph is seen through one eyepiece. The instrument has four mirrors, two mirrors attached to each eyepiece. As the viewer looks through the stereoscope, he/she sees the image of the same object (the overlapping part) on the two photographs and this gives a stereoscopic view by fusion. The terrain is seen in relief due to this.

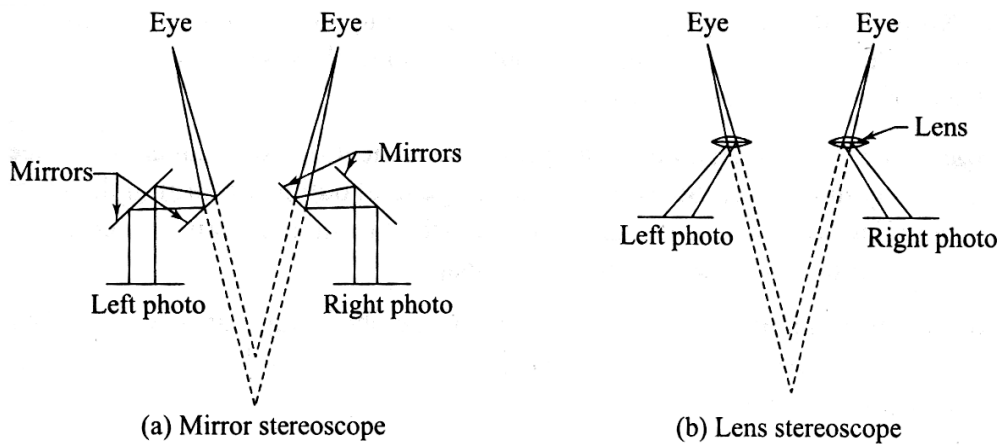

Fig.9.4

**Lens stereoscope:-** A lens stereoscope has two eyepieces through which the observer sees the photographs, providing the experience of stereoscopic or spatial view. The lenses help to magnify the image as seen by each eye. The distance between the eyepieces is adjustable and can be set by the observer as per requirement. This distance is approximately equal to the distance between human eyes. The lenses tend to magnify the object and its height. Lens stereoscopes are more compact than mirror stereoscopes.

### **Photo-interpretation:-**

Photo-interpretation is the key to effective use of photographs. It refers to the accurate identification of the features seen in photographs. Objects seen in photographs are often not easy to recognize, and it takes some amount of skill on the part of the interpreter to correctly identify the objects and judge their significance. It is more difficult to identify objects in vertical photographs than in tilted photographs owing to the familiarity of view in oblique photographs. Colour photographs are easier to interpret than black and white photographs due to tonal variations. A stereoscopic pair is easier to interpret due to the depth available in the photographs when seen through a stereoscope. Considerable amount of practice and experience is required to correctly interpret photographs.

Interpretation of aerial photographs is required extensively in developmental project design and execution. It has been successfully applied in a variety of fields. The success of project planning depends on the effective and efficient interpretation of photographs by engineers and others and others. A good deal of patience and ingenuity is required to interpret photographs.

### **General Features of Photographic Images:-**

The knowledge of some of the basic characteristics of the image in aerial photographs helps helps one to interpret these images. Photo-interpretation requires large-scale photographs. The success of the interpretation depends upon the experience of the person in addition to the conditions under which the photographs should be studied in the correct orientation with respect to the light conditions at the time of photography. Some of the basic features of photographs that help in identification are discussed here.

**Size:-** The size of an object in the photograph is sometimes helpful in interpretation. Knowing the photograph scale, it is possible to have an idea about the size knowing the correct size, one may not confuse among objects having similar shapes such as a river, road, canal, or drain.

**Shape:-** The shape of an object is helpful in identification. Regular shaped objects are generally man-made. Shape relates to the general outline or form of the object. A railway line and a roadway can be distinguished from their form. Objects of the same size can be distinguished from their shape.

**Texture:-** it is simply the variation in tone of the photograph. It is produced by a combination of factors such as size, shape, tone pattern, and shadow. Vegetation and other ground features can be distinguished by the tonal changes.

**Pattern:-** It is the spatial arrangement of objects in a particular set. A habit can be easily distinguished by the arrangement of roads, houses, etc. because of the pattern.

**Shadow:-** The shadow of an object formed during photograph is sometimes helpful in identification, as it shows the outline of the object.

**Tone:-** It is produced by the amount of light reflected back by the object to the camera. If the particular tones associated with specific objects are known, it is easy to identify them.

**Location:-** The location of an object in the photographs helps in identifying the object itself. Knowing the objects or areas surrounding the object, one can identify the main object. Refer Chapter 24 for more on visual image processing.

### **Applications and Advantages of Aerial Surveying:-**

As has been discussed in the preceding sections, aerial surveying finds many applications in map preparation and map revision for large areas. Modern plotting machines and mostly automated operations have simplified the process of preparing maps from aerial photographs. Aerial surveying also finds extensive application in urban planning and development, transportation network design and calculations, disaster management, forestry, mining operations, reservoirs, agriculture, etc.

With advancements in technology, aerial photography has given way to aerial image processing. High-resolution digital image (soft image) can be made and processed using software to prepare excellent maps. All forms of rectification and corrections can be done automatically before converting the data into a map. Digital photogrammetric equipment and software have developed sufficiently to facilitate the preparation of very accurate maps.

### **Aerial Photogrammetry:-**

Terrestrial photogrammetry virtually went out of use with the advent of aerial surveying techniques. Aerial photogrammetry makes use of cameras fitted in an aircraft to photograph an area from an overhead position. The principle of stereoscopic vision is used in studying and interpreting aerial photographs. Therefore overlapping photographs are taken in the direction of flight as well as in the lateral direction as the aircraft flies along a parallel path. It must be understood that while a map is an orthographic projection by projecting points perpendicular to the plane a photograph is a perspective projection, as all the light rays for forming the image pass through a point.

### **Basic Terminology:-**

An aerial photograph is a record of the ground features at a point in time. Aircraft fitted with cameras moves along predetermined paths and takes photographs at planned intervals. The following are the basic terminology used to describe aerial photography.

**Altitude:** - Height of the aircraft above the ground.

**Flying height:** - **Height** of the aircraft above a chosen datum.

**Exposure station:-** Position of the aircraft at the time of exposure of the film. It is essentially the position of the optical centre of the camera lens when film is exposed.

**Air base:** - Distance between two consecutive exposure stations.

**Tilt and tip:** - Tilt is inclination of the optical axis of the camera about the line of flight.  $\phi$  is the tilt. Tip is the inclination of the camera axis about line perpendicular to the line of flight.

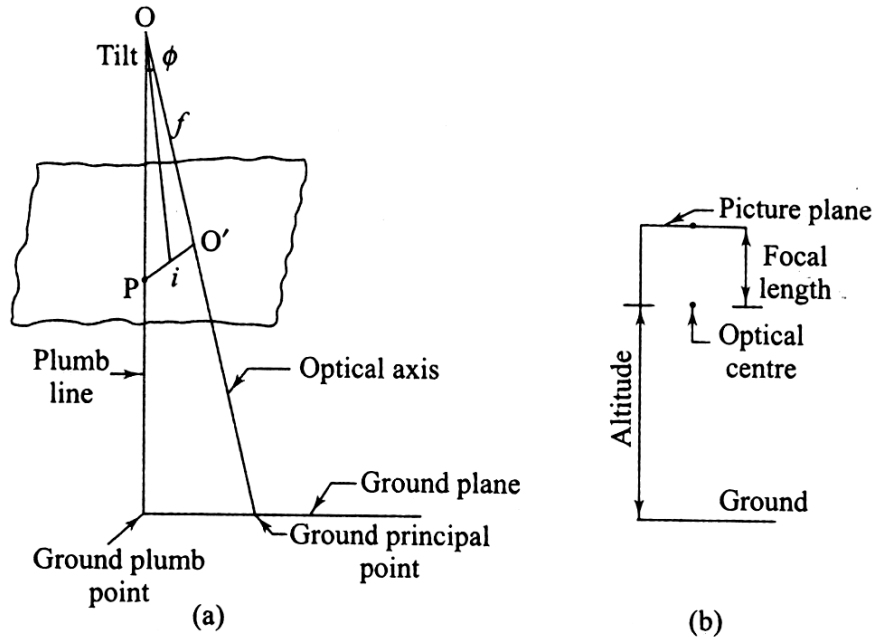

Fig.9.5

**Picture plane:-** Plane that contains the image at the time of camera exposure.

**Ground plane: - Horizontal** surface from which heights can be measured and which can be used as a datum surface.

**Principal point:-** Point of intersection of the optical axis of the camera with the photographic plane. O is the optical centre and O' is the principal point. When the optical axis is extended downwards, the point of intersection with the surface is known as the *principal ground point*.

**Isocentre: -** Point on the photograph at which the bisector of the angle of tilt meets the photographic plane. 'i' is the isocentre, at a distance of  $f \cos \phi$  along the principal line, where  $f$  is the focal length of the camera.

**Plumb points: -** The points at which the vertical line through the optical centre meets the photographic plane and the ground surface. The plumb point on the ground surface is also known as ground nadir point. The plumb point on the photograph is known as nadir point.

**Homologous points: -** Points on the ground and their representations in the photo graph in perspective projection.

## 9.4 Remote Sensing

Remote sensing, as the name implies refers to collecting data from a remote location without being in physical contact with the object. Remote sensing is not as uncommon as we may think. We have many remote sensing activities in day-to-day life. When we see an object and recognize its colour as red, we are using the concept of remote sensing. Similarly, our sense of smell also helps us to use remote sensing. Some of the common methods of remote sensing are described below.

### **Active and passive system of remote sensing:**

In an active system of remote sensing, the sensing equipment emits radiation, which is reflected back from the object. Radar is a typical example of such a system. Radar equipment transmits radiation and the reflected radiation is analysed to determine the distance and presence of any object in the ranging area.

In a passive system of remote sensing, the instrument does not generate and emit radiation. The radiation reflected from an external source is made available to the object. We use the passive system exhaustively in the form of the sun's radiation. Taking a photograph using light from the sun is an example. Photographic cameras, still or motion picture, and television cameras use the passive system of remote sensing.

### **Applications/Uses of Remote Sensing**

Remote sensing has applications in a wide spectrum of areas. Remote sensing can be used for taking sound decision for planning many human development activities. It is also possible to take preventive action as in the case of forest fire and natural disasters, Weather forecasting is another important application. Some of the application areas are given below.

**Land use and land cover analysis:-** Perhaps one of the prime uses of satellite remote sensing is in the study of land use and cover. Land cover through vegetation and specific crop areas can be studied using remote sensing data. Forest cover is an important aspect, which has been studied: the depletion of forest areas has been identified with the help of remote sensing. It is also possible to study crop diseases over large areas.

**Mineral exploration:-** It will be possible to use satellite data and discover the presence of valuable minerals and ores that are vital to economic development. Non-renewable energy resources, such as fossil fuels, can be identified using remote sensing data.

**Environmental studies:-** Global weather phenomena are a major area for study using remote sensing data. Global warming and ozone layer depletion can be continuously monitored using remote sensing. Similarly, oceanographic studies also provide valuable information about the various characteristics of oceans around the world. Assessing water resources, their extent and depletion, snow cover studies, etc have proved to be valuable.

**Archaeology:-** Archaeological studies can make use of remote sensing data. The underlying old settlements can be recognized from remote sensing data and appropriate action can be taken to excavate and study the various aspects of old civilizations.

**Disaster management:** - This is another important application area of remote sensing. It has been possible to predict earthquake hazards by detecting unusual movements in the earth's crust. Floods, landslides, forest fires, etc can be detected on time and appropriate action can be taken for preventive action in disaster management.

**Geomorphology:** - Geological studies can provide valuable data on faults, tectonic movements, rock type identification, etc using remote sensing data.

**Topography and cartography:** - This is another application related directly to surveying. Remote sensing can be used to accurately locate points with reference to ground surveys are difficult or time consuming. This data can be used to prepare maps or revise existing maps.

**Other applications:** - Remote sensing data is now being used to study troop movements, etc for defense purposes. Other applications include urban planning studies, traffic studies, and assessment of earth's resources for various purposes, and so on.

### **Image Interpretation:-**

Image interpretation is the process of extracting useful information from remote sensing data. Both qualitative and quantitative information can be extracted from maps. Earlier, the data was in analog form which is generally interpreted by humans. Today, the data is generally in digital form which can be interpreted by humans or processed by computers. The correct interpretation



of remote sensing data is very important if it is to be useful for the various purposes for which it has been obtained.

### **Visual Image Processing:-**

The remote sensing data can come in either of the two forms – raw data or processes after certain corrections. Visual images can be monochromatic or grey scale images or colour composites or colour photographs. The objective of visual interpretation is to obtain qualitative information about objects seen in the image. This includes finding their size, location, and relationship with other objects the way our eye perceives an object is different from the way remote sensing data is obtained. First, the image is taken from an aerial platform- an aircraft or a satellite. The view from above will be quite different from the view seen from the ground. Second, the sensors used for imaging record radiations from many parts of the electromagnetic spectrum including the visible band. This makes the imagery look different from what we see otherwise. Third, resolution obtained and scale of the image may be quite unfamiliar to the eye. Finally, the ground relief feature may not be evident in two-dimensional photograph or image. Stereoscopes are used to view photo pairs having common imagery to get a feeling of depth.

The following three processes are involved in image interpretation:

- (1) Image reading is the first step in image interpretation and involves identifying objects in the image by their size, shape, pattern, etc.
- (ii) Measurement from images is the extraction of information such as length, width, height, and other parameters like density or temperature from data keys as reference.
- (iii) image analysis is the understanding of the information extracted and comparing with ground reality or the status of the features as existing at the time of imaging.

Visual interpretation as it is done using photographs has to be supported by ground investigation for correctness of the interpretation. This becomes very necessary as the image may have many features which are not immediately understandable by the interpreter. Multiple images in multiple scales and multi- spectral images have to be interpreted and verified before reaching any conclusion.

### **Elements of visual Interpretation:-**

Some key elements that assist the interpreter in studying and extracting information about the objects in the image are the following:

**Location: - It** refers to the information about the objects in the image in terms of any of the coordinate systems used such as latitude, longitude, and elevation. If some points are available in the image with known coordinates, then the coordinates for other points or objects can be obtained by measuring distances from the known points. Actual ground surveys can also be performed using easier methods that use GPS or by traditional methods of surveying that use total station to get coordinates. Computer processing of the image after rectification can also be employed to get information about coordinates.

**Size: -** The size of an object seen in an image depends upon the scale of the image. Knowing the scale of the image, the length, width, perimeter or area can be used to extract information about the subject. The absolute size of an object along with its relative size is also important in distinguishing between features having the same shape. The size can help distinguish between objects of the same shape such as a building or a football field.

**Shape:-** The shape of an object is distinguishable in the image and can help the interpreter to identify the object. Objects of regular shapes such as rectangles square, circle or oval are generally man-made structures. Irregular boundaries of an object generally mean that the object is of natural origin such as forest area or a lake. Since the imaging is done from above, it is necessary to know how an object looks from the top.

**Shadow:-** Shadows are generally not desirable in images as they change the nature of the image that would have been seen otherwise. However, shadows help in finding the heights of tall structures like towers and multi-storey buildings. Shadows are created due to low sun angles. In addition to aiding in ascertaining the height of objects, shadows also provide a profile view of objects which is helpful in identification.

**Tone: -** It is the relative brightness or colour intensity of the image. A black and white photograph is a grey tone image with brightness ranging from black to white. The remote sensing sensor receives and displays a band of the spectrum of electromagnetic radiation and this is displayed as continuous shades of grey which gives different tones in the image. Tones are useful

features of interpretation because different objects give unique tonal qualities due to their reflectance. Tonal differences can occur due to different bands in multi-spectral images. Experience and a clear eye help to distinguish the tonal variation.

**Color :-** Color images are obtained from colour films. Colour photographs or images hold a lot more information than black and white grey tone images. From the natural colour of the image in the film many features like vegetation can be identified. Colour can change depending upon the type of film and filters used. Colour corrections can be done to images to give true colours of the objects.

**Texture:-** It can be defined as the characteristic placement and variations in definite patterns for objects in the grey tone image. Textures are classified as smooth or coarse. This is due to the visual impression created by the tonal changes. Coarse textures are due to sudden changes due to abrupt changes in tone in small patches giving a mottled appearance. Smooth texture comes from very little changes in tone. Texture helps to identify objects in an image due to characteristic textures of objects, especially vegetation and forest trees.

**Pattern: -** It refers to the randomness or regularity of similar objects in the image. The pattern seen in the image is helpful in identification. Arrangement of trees in a forest is random, while trees in an orchard are placed in an orderly way. Same is true of houses in a neighborhood or buildings in a developed area. Such patterns can be identified and the objects recognized from the pattern.

**Elevation: -** As mentioned in Chapter 22, stereoscopes are used in association with photo pairs to have a view of the difference in elevation of objects. The overlapping areas of the images in photo pairs are useful in finding the elevations of points and also to have an idea about the relative heights of different objects seen in the image.

**Interpretation keys: -** These are used to help in visual interpretation of images. The keys are prepared by experienced interpreters who from past experience and ground verification prepare keys based on major elements of identification. Keys can be prepared for specific uses such as forestry, urban studies, network studies, and so on.