



**UTKAL GOURAV MADHUSUDAN INSTITUTE OF
TECHNOLOGY, RAYAGADA | Govt. of Odisha**

ଉତ୍କଳ ଗୌରବ ମଧୁସୂଦନ ବୈଷୟିକ ଅନୁଷ୍ଠାନ, ରାୟଗଡ଼

CIRCUIT THEORY

&

SIMULATION LAB

MANUAL

3RD SEMESTER E&TC ENGG.

**DEPTT. OF ELECTRONICS &
TELECOMMUNICATION
ENGG.**

U.G.M.I.T.

RAYAGADA

Pr2. CIRCUIT THEORY LAB

(Common to ETC, AE&I)

Practical : 4 Periods per week
Total Periods : 60 Periods
Examination : 3 Hours

Sessional : 25 Marks
Term End Exam : 50 Marks
TOTAL MARKS : 75 Marks

Rationale:

The Circuit Theory Lab can provide knowledge of measurements of various parameters, verification of different circuits and measuring instruments. Using p-spice software / TINA software student can able to analyse the circuits in the computer and simulate the DC/AC analysis easily for efficient outputs. This lab involved principles of operation of electrical and electronic test equipment and applications to measurement of circuit parameters with transient and steady state response of RLC networks & applications of laws and theories of circuits. Design, prototyping, and testing of electronic devices and circuits

Objective:

After completion of this course the student will be able to:

1. Measurement of Resistance, Voltage, Current, Voltage, Current in A.C & D. C.
2. Measurement of Circuit Parameters by LCR meter
3. Verification of Theorems
4. Determine resonant frequency of series R-L-C circuit.
5. Study of High Pass & low pass filter, Band pass Filter and Band Elimination Filter and determination of its cut-off frequency.
6. Know circuit diagram and explain response of series & parallel resonant circuit
7. Analysis the charging and discharging of an R-C & R-L circuit with oscilloscope.
8. Know rise time, overshoot, damping factor
9. Know Circuit simulation using P-SPICE software. & Construct different circuits using P-SPICE software and compare the measurements and wave forms.

List of Practicals (Any 08 including sl no 11)

1. Measurement of Resistance, Voltage, Current in A.C & D. C. Circuit by using digital Multimeter & Clamp meter
2. Verification of
 - (a) Super positions Theorem
 - (b) Thevenin's Theorem
 - (c) Norton's Theorem
 - (d) Milliman's Theorem

(e) Maximum power theorem

3. Determine resonant frequency of series R-L, R-C, R-L-C circuit and study the quality factor and bandwidth.
4. Determine the resonant frequency, Q factor & Band width of parallel resonant circuit
5. Determine the time constant of R-L-C circuit and analysis the transient response (rise time, overshoot, and damping factor from the oscilloscope)
6. Study of Low Pass filter and determination of cut-off frequency.
7. Study of HighPass filter and determination of cut-off frequency.
8. Study of Band pass Filter and Band Elimination Filter and determination of its cut-off frequency.
9. Determination of Parameters of Two Port Network (T & Y)
10. Design attenuator circuit (pie or T)
11. Mini Project using P-SPICE software: To collect data of catalogues and specification sheet of all the equipment & components used for performing experiment and submit the project on P-SPICE software into Analysis and Plot the graph of each measurement at the end of semester e.g. Butter Worth Filter

CONTENTS

SL NO	LIST OF EXPERIMENT	PAGE NO
1	Verification Of KVL And KCL	03-05
2	Verification of Superposition Theorem	06-08
3	Verification Of Thevenin's Theorem	10-12
4	Verification Of Norton's Theorem	13-15
5	To Verify the Millman's Theorem	16-17
6	To Verify the Maximum Power Theorem.	18-19
7	To Determine the Resonant Frequency factor And Band Width	20-24
8	To Determine the Resonant Frequency Q Factor and Bandwidth of a Parallel Resonance Circuit	25-29
9	Study of Low Pass Filter and Determination Their Cut – Off Frequency	30-32
10	Study of High Pass Filter and Determination of Its Cut Frequency	33-35
11	To Study Bandpass Band Elevation filter and Determination Their Cut – Off Frequency	36-38

EXPERIMENT - 1

AIM OF THE EXPERIMENT: -

Verification of KVL and KCL.

APPARATUS REQUIRED: -

- KVL, KCL Kit
- Connecting wires
- Multimeter

THEORY: -

In simple circuits the resistance and potential difference are calculate with the help of ohm's law, but in actual practice, we come across complicated circuit which contain a large number of resistances along with Several sources of E.M.F in such cases the effective resistance and the E.M.F cannot be calculated easily from ohm's Law.

In order to solve such networks, Kirchhoff gave two laws i.e.

- Kirchhoff's Current Law
- Kirchhoff's voltage Law

Kirchhoff's Current Law: - According to Kirchhoff's Current Low, the algebraic sum of all the currents meeting at a junction in a closed electrical circuit is zero.

Kirchhoff's Voltage Law: - According to Kirchhoff & Voltage law, the algebraic sum of all the voltage around any Closed Path is zero.

PROCEDURE: -

Kirchhoff's voltage Law

1. The circuit is connected as per the circuit diagram.
2. Supply is switched on and voltage is measured.
3. The voltage across all the resistor is measured.

Kirchhoff's Current Law

1. The circuit is corrected as per the circuit diagram
2. The current is measured though each parallel path long ammeter.
3. The circuit current is measured by ammeter.

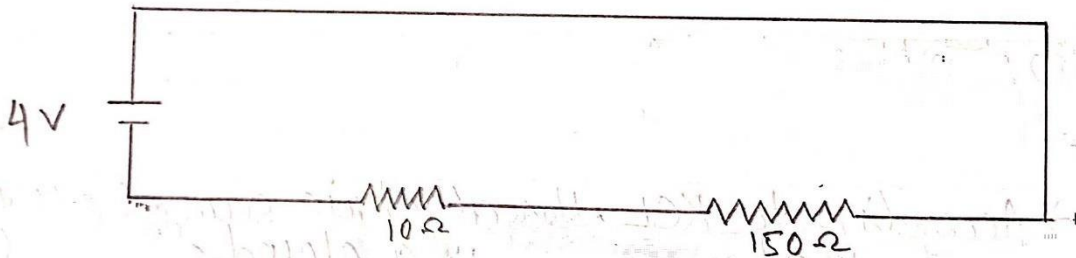
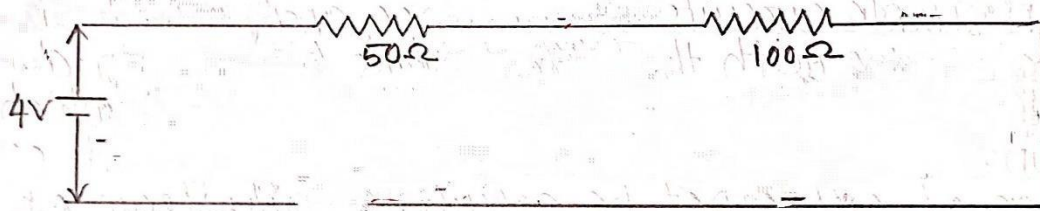
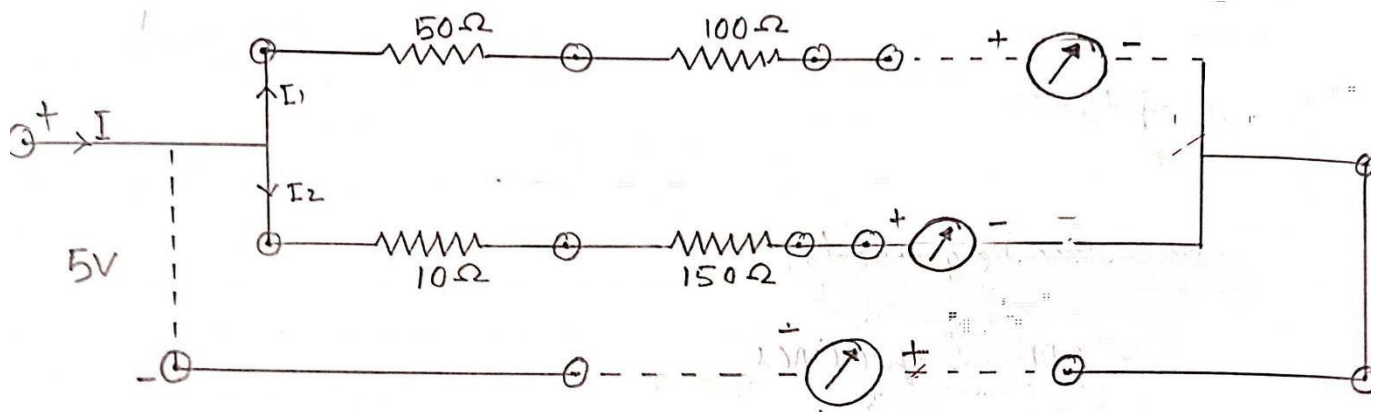

OBSERVATION:-

OKCL

SL NO	SUPPLY VOLTAGE		Current Through Each Resistor		
	V1	V2	I1	I2	I=I1+I2
1					
2					
3					
4					
5					

OKCL

V1	V2	V=V1+V2	I (I n m A)

CONCLUSION: -

Hence, it concluded that the KVL and KCL has been verified.

EXPERIMENT - 2AIM

OF THE EXPERIMENT: -

Verification of Superposition Theorem.

APPARATUS REQUIRED: -

- Practical Kit Board
- Connecting wire
- Multimeter

THEORY: -

The superposition theorem states that in a linear bilateral multi source DC circuit, the current through or voltage across any particular element may be determined by considering the contribution of each source independently with the remaining sources replaced with their internal resistance. The contributions are then summed, paying attention to polarities, to find the total values. Superposition cannot be applied to Non-Linear circuits or Non-Linear functions such as power.

PROCEDURE: -

- I. Make the connections as shown in the circuit diagram.
- II. Switch on both power supplies, adjust them to required values, measure the current flowing through the branch as shown in the circuit diagram using a multimeter.
- III. Now keep only one supply active and short the other, measure the current flowing through the same branch.
- IV. Repeat the same procedure by acting with the second supply alone, measure the current through the same branch.
- V. Check whether the superposition theorem is verified analytically and practically.

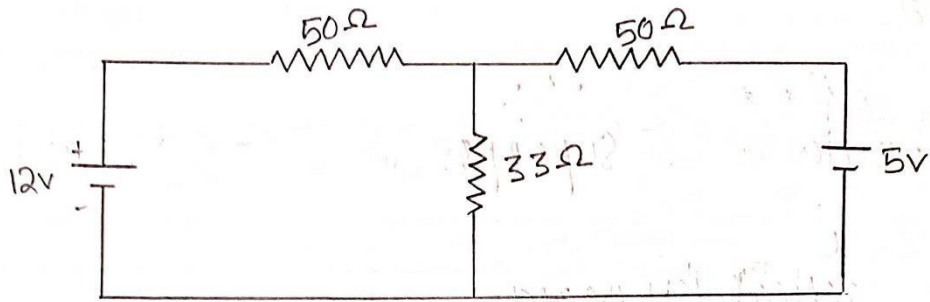

(Fig-1)

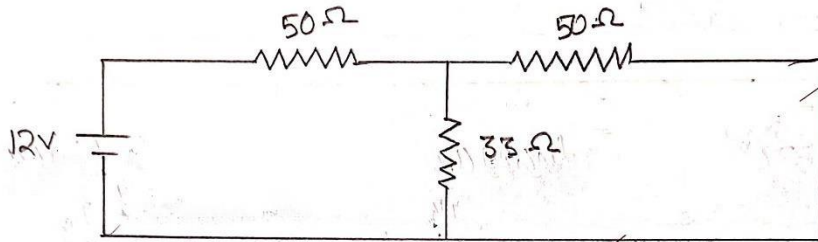

(Fig-2)

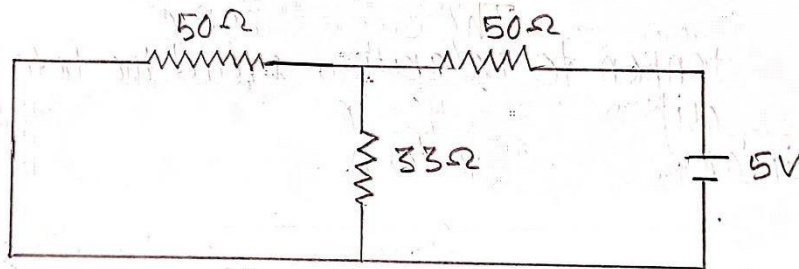

(Fig-3)

OBSERVATION: -

Considered (12v)		Considered (5v)		Total Current
Supply Voltage	V1	Supply Voltage	V2	$I = v1+v2$
12 Volts	79mA	5Volts	42mA	$I = 19+42 = 121mA$

CONCLUSION: -

Hence, it has concluded that superposition theorem has been verified.

EXPERIMENT - 3

AIM OF THE EXPERIMENT: -

Verification of Thevenin's theorem.

APPARATUS REQUIRED: -

- Thevenin's Theorem Kit
- Patch cords (As per requirement)
- Multimeter

THEORY: -

By using the Thevenin's Theorem any complicated circuit can be replaced by a single voltage source series with impedance, this is called Thevenin's Theorem on Thevenin equivalent Circuit. It is a simplified circuit. The Theorem has Provided a Powerful Means of Network Analysis.

STATEMENT OF THEVENIN'S THEOREM: -

Any two terminal bilateral linear IC circuits can be replaced by an equivalent Circuit connecting of a voltage source and a series resistor.

PROCEDURE:

- I. Connection is given as per of the circuit diagram.
- II. Set a particular value of voltage and note down the corresponding ammeter reading.
- III. Remove the load resistance (R_L) and measure the open (v_{th}) circuit voltage using Multimeter.
- IV. To find R_{th} remove the voltage source and short circuit it and find R_{th} using multimeter.
- V. Given the Connection for equivalent circuit and set v_{th} and R_{th} and note the ammeter reading.
- VI. Verify Thevenin's Theorem.

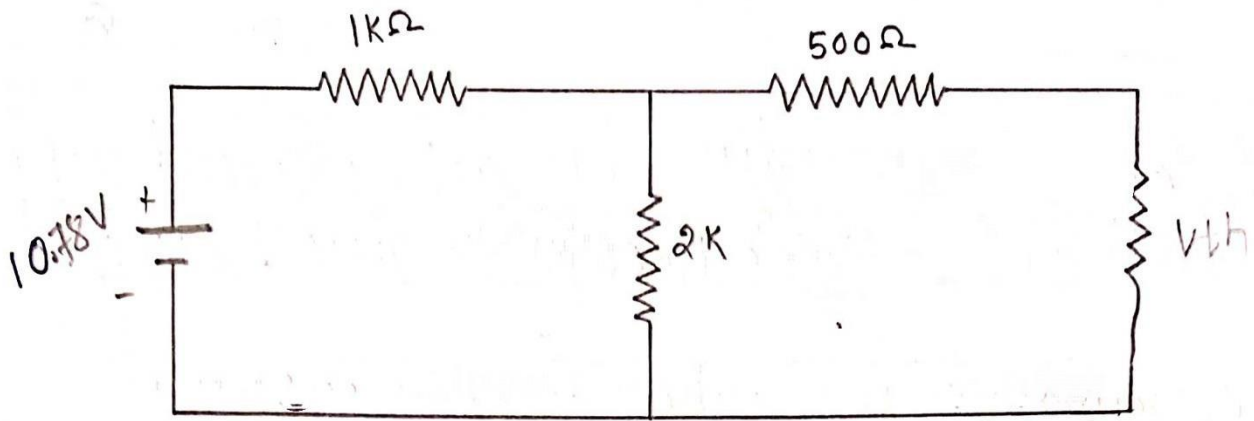

(Fig-1)

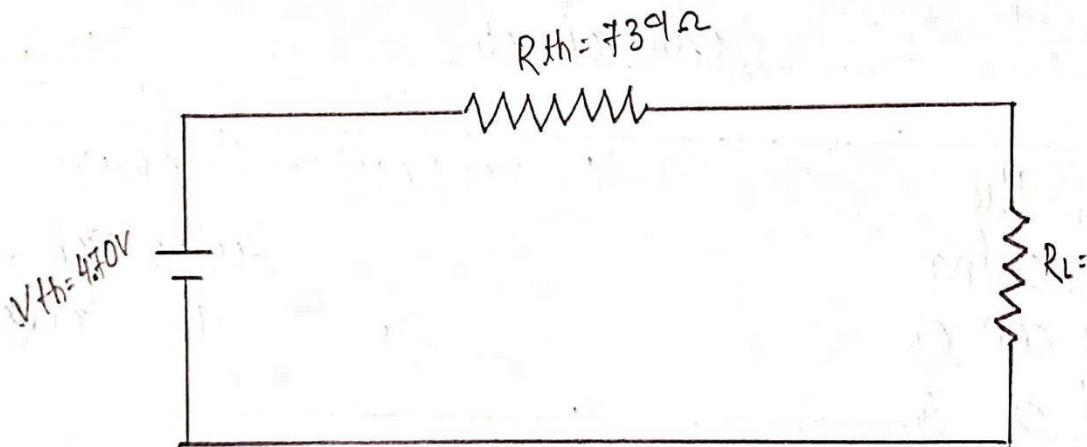
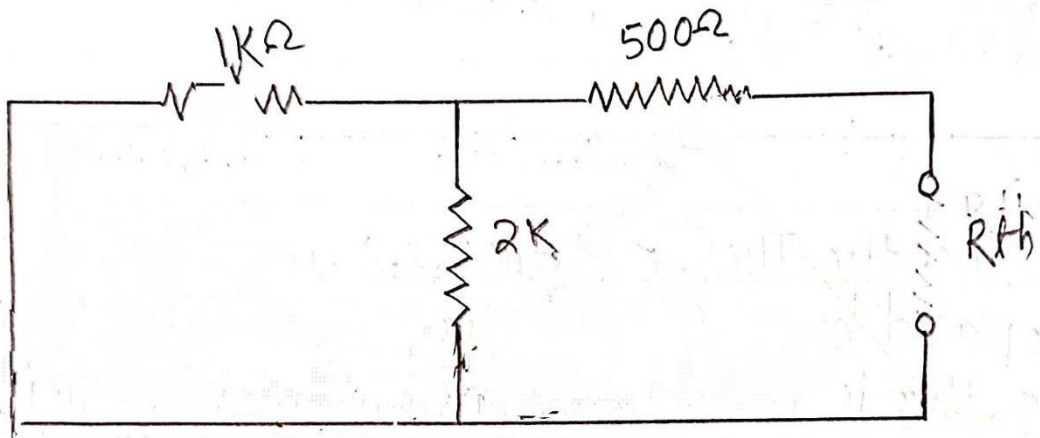

OBSERVATION: -

SUPPLY VOLTAGE	THEVENIN'S RESISTANCE (Rth)	THEVENIN'S VOLTAGE (Vth)	LOAD CURRENT $I_L = V_{th} / (R_{th} + R_1)$	IL PRACTICALLY

CONCLUSION: -

Hence, the Thevenin's Theorem is verified practically and theoretically.

EXPERIMENT - 4

AIM OF THE EXPERIMENT: -

Verification of Norton's Theorem.

APPARATUS REQUIRED: -

- Norton's Theorem kit
- Patch cards
- Multimeter

THEORY: -

Norton's Theorem is similar to Thevenin's Theorem. It states that any two terminal linear active network consisting of dependent or independent Voltage and Current sources and linear bilateral Network element can be replaced by an equivalent circuit consisting of a Current source being the short circuited current across the Load Terminal and The resistance being the internal resistance of the source network looking through the open circuited Current across the Load terminal and the resistance being the internal resistance of the through the source network looking open circuited loads terminals.

PROCEDURE: -

- I. Connections are given as per circuit diagram.
- II. Set a particular value of voltage and note the corresponding ammeter readings in the circuit.
- III. Remove the RL and short circuit the terminals.
- IV. For the same voltage note down the ammeter readings.
- V. Remove the RL and short circuit the terminal and note down resistance across two terminals.
- VI. Set I_N and R_N and note down the ammeter readings verify Norton's theorem.

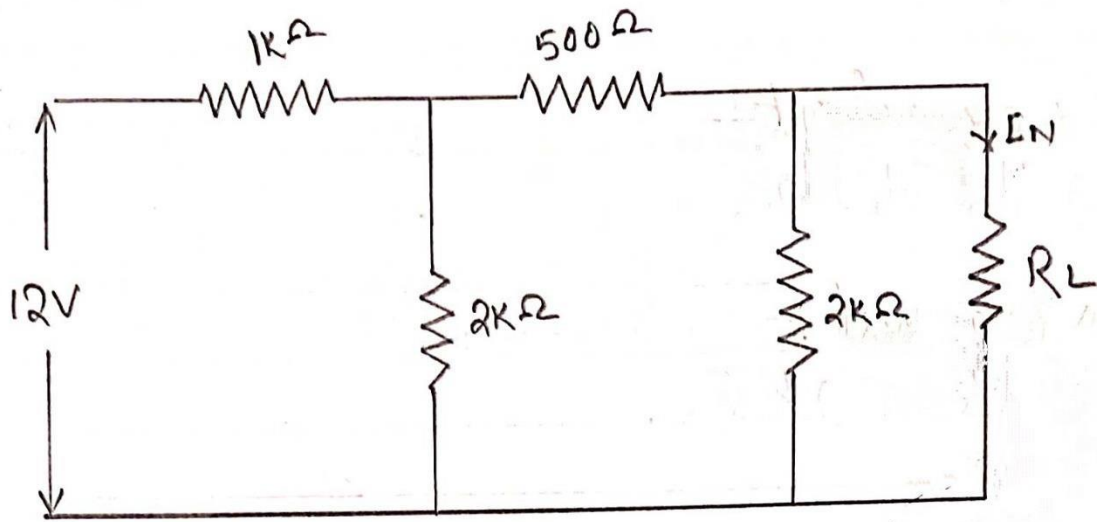

(fig-1)

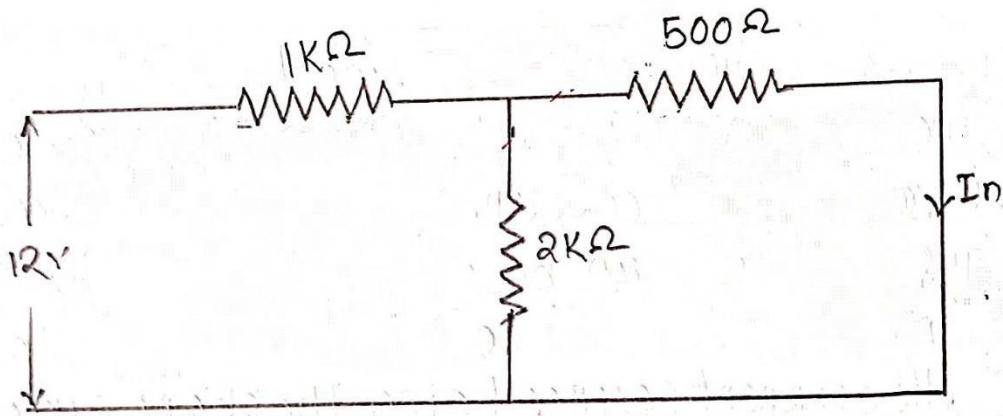

(fig-2)

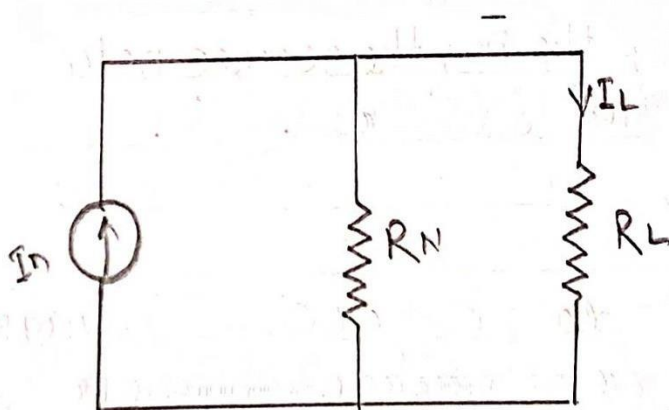

(fig-3)

OBSERVATION: -

SUPPLY VOLTAGE (V)	NORTON'S RESISTANCE (RN)	NORTON'S CURRENT (IN)	LOAD CURRENT $I_L = I_N \times R_N / (R_N + R_L)$	LOAD (RL) RESISTANCE

CONCLUSION: -

Hence, the Norton's Theorem is Verified.

EXPERIMENT: 5

AIM OF THE EXPERIMENT: -

To verify the Millman's Theorem.

APPARATUS REQUIRED:

- Bread Board
- Volt meter
- Resistor
- Multimeter
- R.P.S

THEORY: -

This theorem states that so any network. If the voltage source $V^1 V^2 \dots V_n$ in series with their Terminal / internal Resistance $R_1 R^2 \dots R_n$ Respectively are one in parallel than these Source may be Replaced by a Single Voltage Source 'V' in Series with R^1 .

$$V_1 = \frac{V_1 G_1 + V_2 G_2 + \dots + V_n G_n}{G_1 + G_2 + G_3 \dots G_n}$$

$$R_1 = \frac{1}{G_1 + G_2 + G_3 \dots G_n}$$

PROCEDURE:

- Connect the circuit as per the Circuit Diagram.
- Measuring the Current through R^3 Resistor.
- Observe that the two Current are same.
- Connect the circuit shown in fig and measure the current through R^3 .

TABULATION: -

Serial No	Parameter	Theistical Value	Practical value

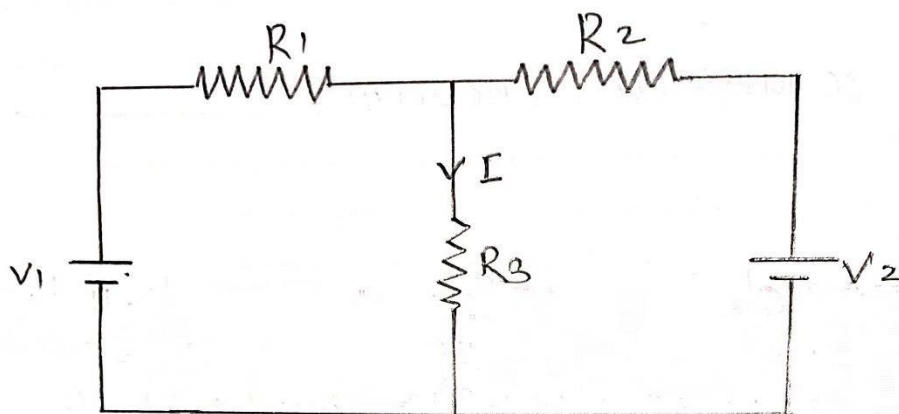

(Basic Circuit)

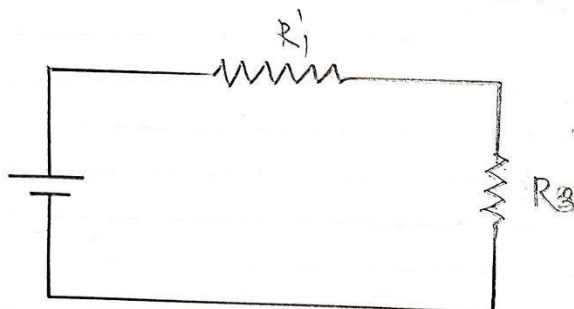

(Millman's equivalent circuit)

CONCLUSION: -

Hence the millman's theorem is verified successfully.

EXPERIMENT: 6

AIM OF THE EXPERIMENT: -

To Verify the Maximum Power Theorem.

APPARATUS REQUIRED: -

- Maximum Power Transfer Theorem Kit
- Connecting Probes
- AC Supply

THEORY: -

The Maximum Power Transfer Theorem States that Maximum Power is Transfer / Delivered from a Source to a Load Resistance When the Load Resistance is Equal to Source Resistance.

($R_L = R_s$ is the condition Required for Maximum Power Transfer)

PROCEDURE: -

1. Connect the circuit as Per the Circuit Diagram.
2. Vary the load resistance in steps and note down voltage across the load and Current flowing through the circuit.
3. Calculate power Delivered to the load by Using Formula $P = V \times I$.
4. Draw the Graph Between Resistance and Power.
5. Hence, We can Prove Or Verify the maximum power is delivered to the load when $R_L = R_S$.

TABULATION:-

SL NO	R. L	V	I	P =VI	RL
1					
2					
3					
4					
5					

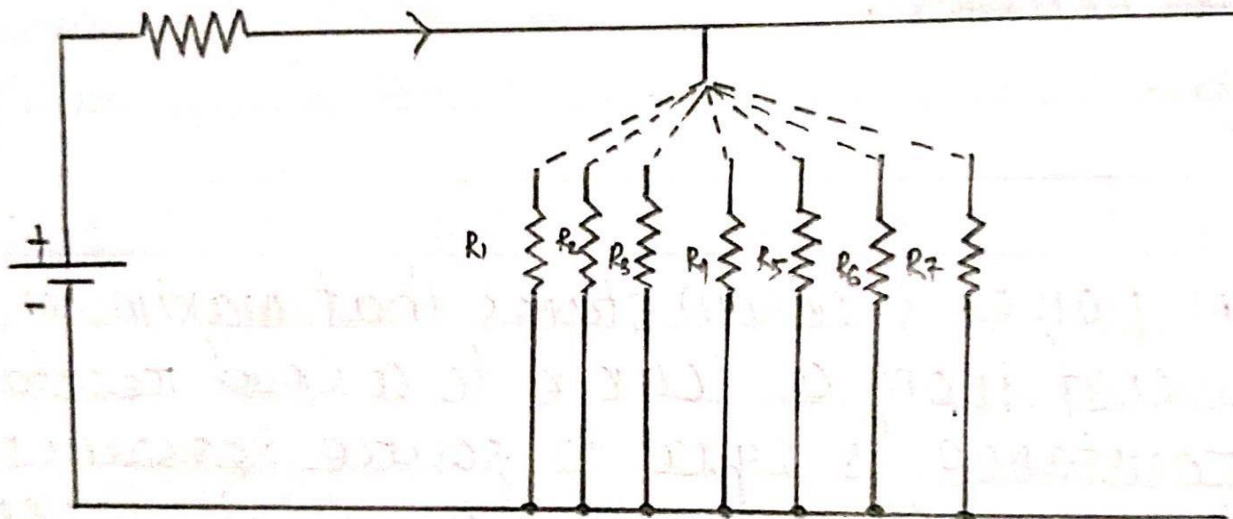

CONCLUSION: -

Hence the maximum power transfer theorem is verified successfully. 7

EXPERIMENT: -7

AIM OF THE EXPERIMENT: -

To determine the Resonant Frequency of series RLC circuit and Study the Q factor and Bandwidth

APPARATUS REQUIRED: -

- RLC series circuit kit
- Multimeter
- Connecting wire
- AC Supply

THEORY: -

Electrical Resonance is occurred in an Electric circuit at a Particular Resonant Frequency when impedance or admittance at circuit element cancel each other.

The resonant Frequency (FR) of RLC Circuit is the frequency at which the amplitude of current is a maximum and circuit would oscillate if not given by a voltage source.

at resonant $X_L = X_C$

$$\begin{aligned} &= \omega L = \frac{1}{\omega C} \\ &= 2\pi f L = \frac{1}{2\pi f C} \\ &= f^2 = \frac{1}{(2\pi)^2 LC} \end{aligned}$$

$$= f = \frac{\sqrt{1}}{(2\pi)\sqrt{LC}}$$

$$FR = \frac{1}{2\pi\sqrt{LC}}$$

Firstly, let us define what we already know about series RLC circuit.

- Inductive reactance: $X_L = 2\pi fL = \omega L$ • Capacitive reactance: $X_C = \frac{1}{2\pi fC} = \frac{1}{\omega C}$
- When $X_L > X_C$ the Circuit is Inductive.
- When $X_C > X_L$ the Circuit is Capacitive.
- Total circuit Impedance: $Z = \sqrt{R^2 + (X_L - X_C)^2}$ OR $\sqrt{R^2 + (X_C - X_L)^2}$

★ From above equation for inductive reactance, if the frequency is increased the overall inductive reactance value of inductor would also increase. As the frequency approaches infinity, the inductor resistance would also increase towards infinity with the circuit element acting like an open circuit.

This means, inductive reactance is proportional to the frequency and is small of low frequency and high at higher frequency.

★ If the frequency is increased the overall capacitive resistance is decreased. As the frequency approaches infinity, the capacitors reactance would reduce to practically zero, causing the circuit element to act like a perfect Conductor of 0

This means then that capacitive reactance is inversely proportional to the frequency we can see the value of these resistance depends upon the frequency of the supply. At Higher frequency X_L is high and at low frequency X_C is high. Then there must be a frequency point where the values at X_L is same as the value of X_C . If we now place the curve of inductive reactance on top of the curve for capacitive reactance so that both Curves are on same axis, the point of intersection will give us the series resonance frequency point (FR)

Electrical resonance occurs in an AC circuit When the two reactance which are opposite and equal cancel each other out as $X_L = X_C$, In series resonant, the resonant frequency, FR can be calculated as.

$$FR = \frac{1}{2\pi \sqrt{LC}}$$

★ At resonance the impedance of the series circuit is minimum and equal to the Resistance. R. The circuit impedance at resonance is called dynamic impedance of the circuit.

QUALITY FACTOR: -

The sharpness of the peak is measured Quantitatively and is called quality factor, Q, Q Of the circuit. The quality factor relates the maximum energy Stored in the circuit to the

Series RLC circuit

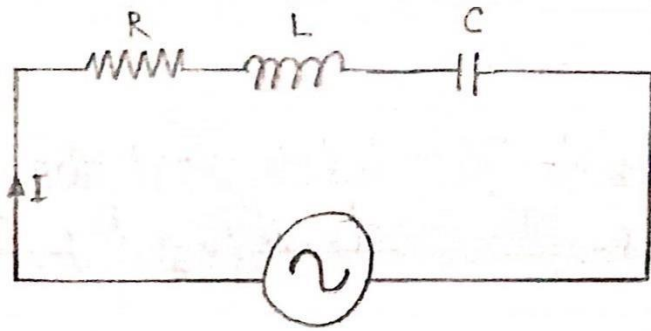

Inductive Reactance against frequency

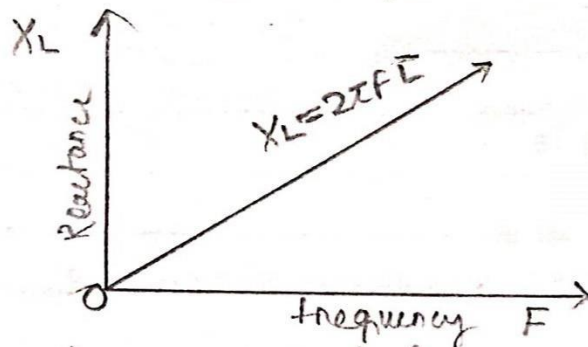

Capacitive Reactance against frequency

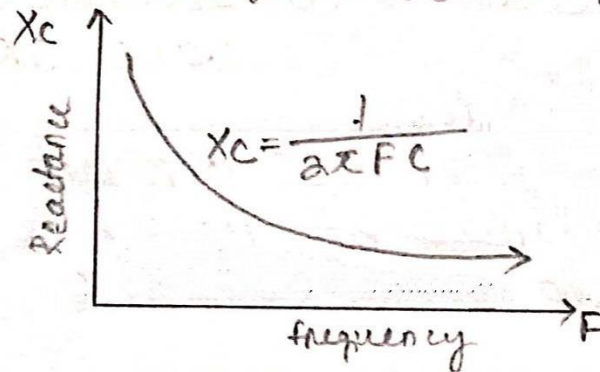

Series Resonance frequency

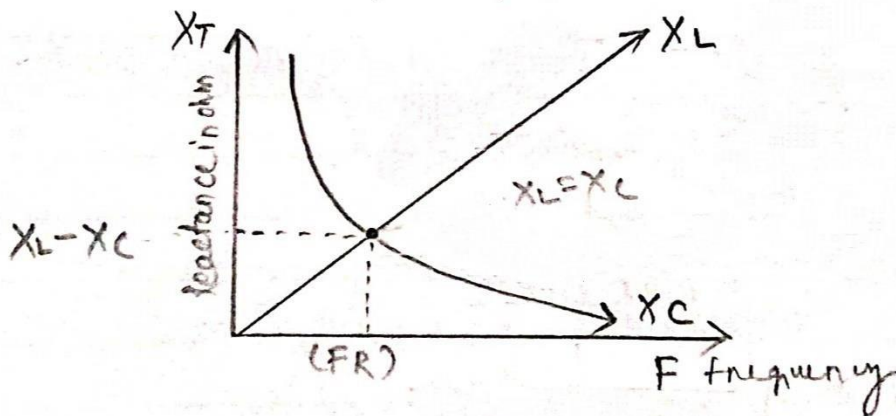

Impedance in a Series Resonance Circuit

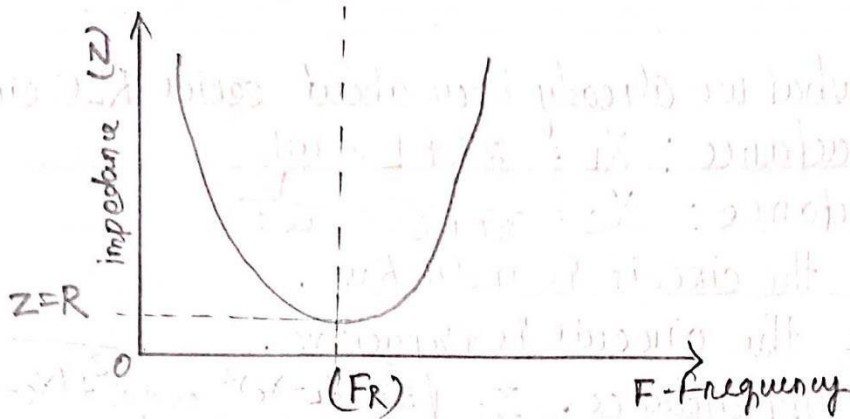

Circuit current at series resonance circuit

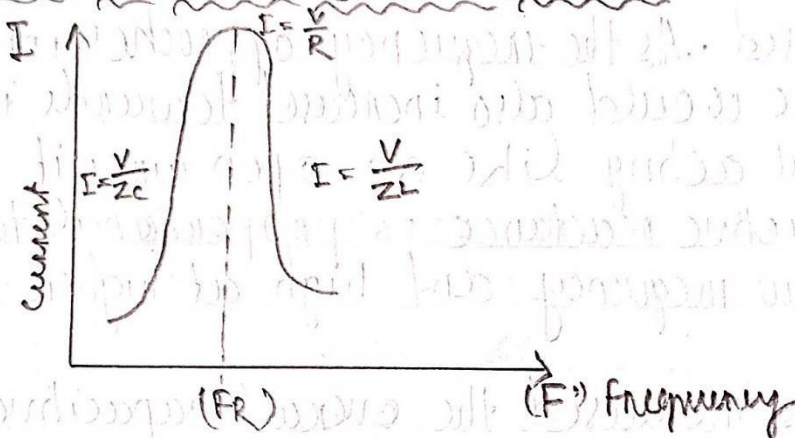

Bandwidth of Series Resonance Circuit

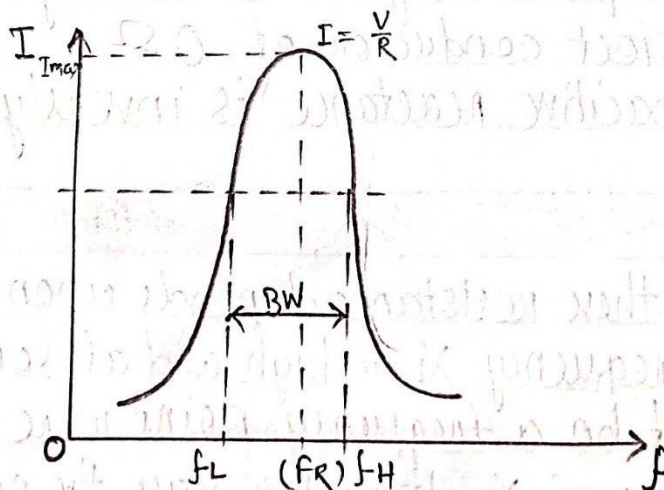

Energy Dissipated during each cycle of oscillation in meaning that it is a ratio at resonant frequency to bandwidth and the higher the circuit Q, the smaller the bandwidth. $Q = F_x / BW$.

BANDWIDTH OF SERIES RESONANCE CIRCUIT: -

$$\text{Bandwidth of Series Resonance Circuit} = \frac{F(R)}{Q}$$

TABULATION: -

SL NO	Frequency Applied	Capacitor(C)	XC(Ω)	Inductance (L)	XL (Ω)
1					
2					
3					
4					

From the above tabulation we can find that the resonant frequency

$$F_R = 355.9 \text{ WHEN } (X_L = X_C)$$

CONCLUSION: -

Hence, we have successfully determined the resonant frequency of a series RLC circuit and studies the Q factor and band width.

EXPERIMENT - 8

AIM OF THE EXPERIMENT:

To Determine Resonant frequency, Q factor and Band width of a parallel resonance Circuit.

APPARATUS REQUIRED: -

- Parallel resonance trainer kit.
- Multimeter
- CRO
- Connecting probes.
- AC supply.

THEORY: -

- Parallel resonance is a resonance condition that usually occurs in parallel resonant circuits Where the voltage becomes a maximum of a given circuit.
- Resonance occurs to the two-branch network Containing capacitance in parallel with inductance L and resistance R series: When the current I_L is equal to I_C . At this condition this supply currents in phase with Supply voltage V.
- The frequency of which the reactive. Component of Line current is zero is called as resonant frequency.

for occurring parallel resonance, I_C must be equal to I_L or

$$I_C - I_L \sin\phi = 0$$

Where,

I_L = Current through coil (lags behind the voltage by an angle)

I_C = Current through capacitor (lead the voltage by an angle 90°).

$$I_C = I_L \sin\phi$$

$$= \frac{V}{X_C} = \frac{V}{Z_L} \sin\phi$$

$$= I = \frac{X_L}{Z_L} \sin\phi$$

$$= (Z_L)^2 \sin^2\phi = X_L \cdot X_C$$

$$\sin^2\phi = \frac{X_L}{Z_L^2} = \frac{X_L}{X_C} = \frac{\omega L}{\omega C}$$

$$Z^2 = L$$

$$= (ZL) C$$

$$\sqrt{R^2 + (XL)^2} = L$$

$$= (R C)$$

$$R^2 + (XL)^2 = L$$

$$= R C$$

$$R^2 = L - R^2$$

$$= (XL) C$$

$$R^2 = L - R$$

$$= (WL) C$$

$$L - R^2 = L$$

$$= W^2 = C L^2$$

$$= W^2 = C - \frac{R^2}{L}$$

$$L - \frac{R^2}{L} = L$$

$$= W = \sqrt{\frac{1}{LC} - \frac{R^2}{L^2}}$$

$$= 2 \pi f r = \sqrt{\frac{1}{LC} - \frac{R^2}{L^2}}$$

$$= F_r = \frac{1}{2\pi} \sqrt{\frac{1}{LC} - \frac{R^2}{L^2}}$$

Q - Factor

The selectivity or Q factor for parallel resonance circuit is generally defined as the ratio.

$$Q = \frac{R}{\omega L}$$

$$= \frac{R}{2 \pi f L}$$

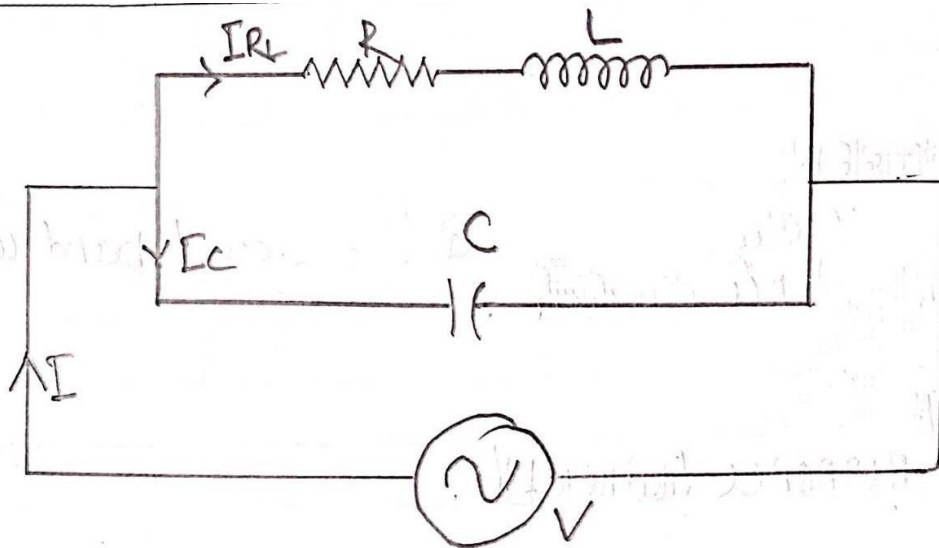

Phasor

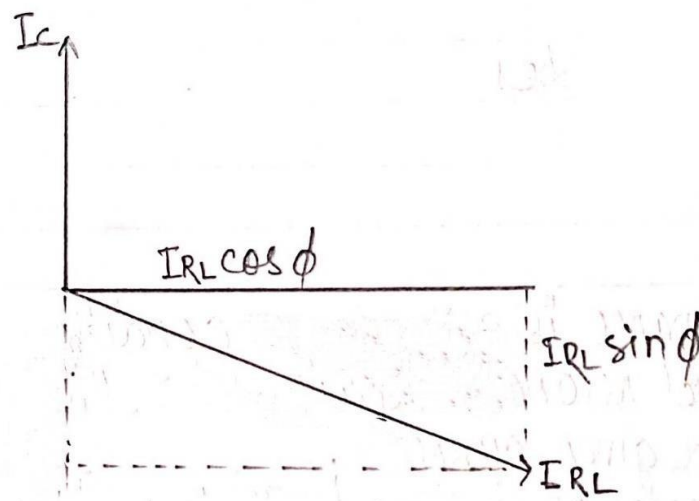

Resonant Curve

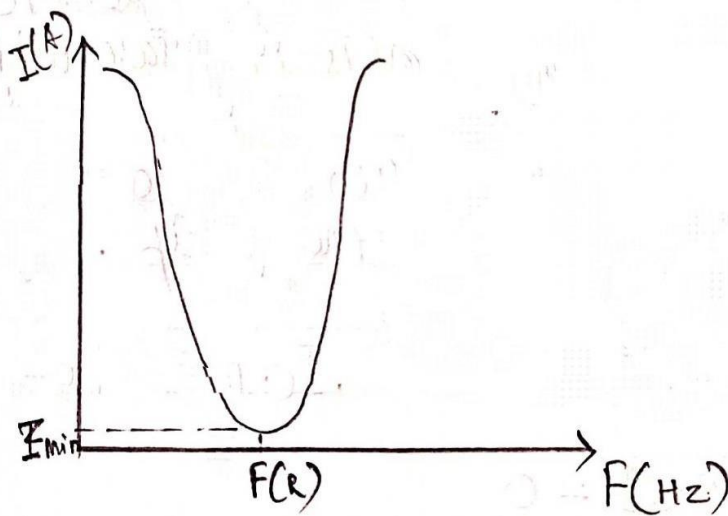

Impedance in a Parallel Resonance CKT

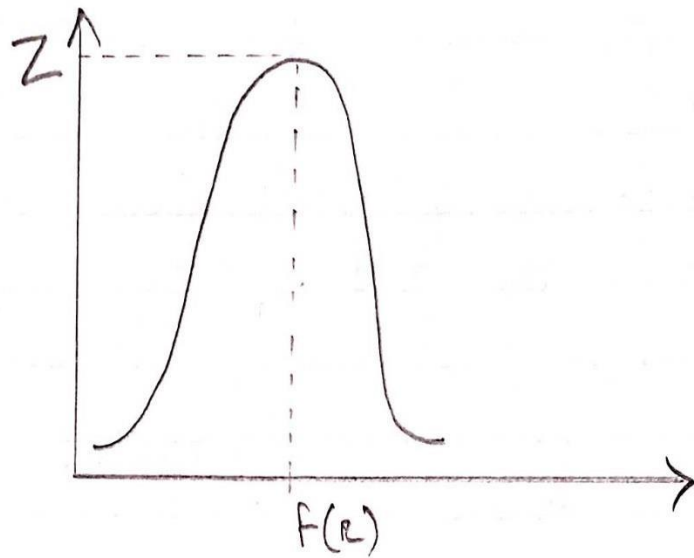

Band width of a parallel Resonance circuit

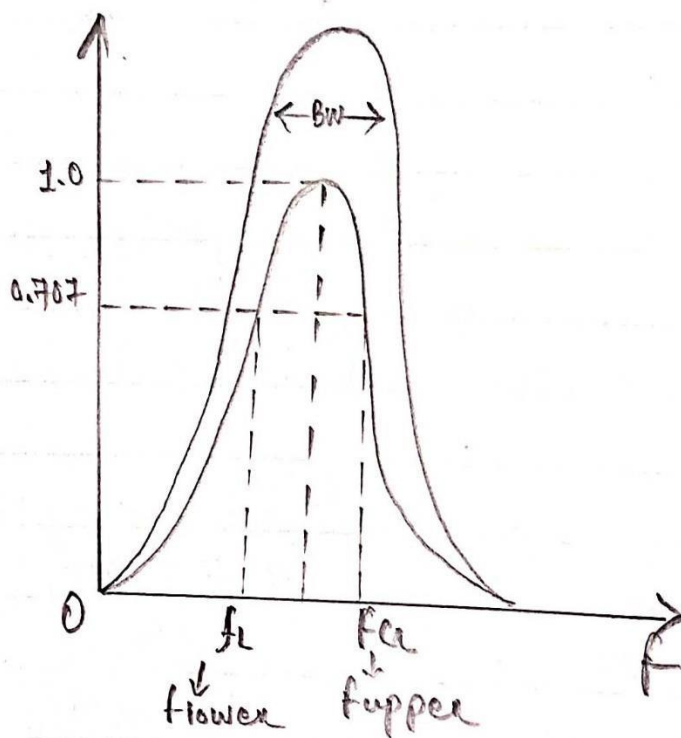

BANDWIDTH: -

The bandwidth of a parallel Circuit is defined as the same way for the Series resonance Circuit. The upper and Lower Cut off frequencies given as: f_{upper} and f_{lower} respectively denoted by half power frequencies where the power dissipated in

the circuit is half of full power dissipated at resonant frequency $0.5 \times I^2 R$ which gives us the same - 3 dB point at Current value is equal to 70.7% of its maximum resonant value.

Bandwidth can be Calculate by.

$$\boxed{BW = FR/Q}$$

OR

$$\boxed{BW = F_{upper} - f_{lower}}$$

CONCLUSION: -

Hence, we have successfully determined the resonant frequency of parallel RLC Ckt also a factor and Band.

EXPERIMENT – 9

AIM OF THE EXPERIMENT: -

Study of low pass filter and determination of its cut-off frequency.

APPARATUS REQUIRED: -

- Resistances •Capacitances.
- Function generator
- CRO
- Dual power supply.
- Connecting leads.

THEORY: -

If a filter passes low frequency and rejects high ones, it is said to be a low pass filter. A frequency is considered passed if its magnitude (voltage Amplitude) is within 70% (Or 1/2) of the maximum amplitude passed. Otherwise, the 70% frequency is known as Corner frequency, roll off frequency, or half-power frequency. The corner or cut-off frequency for R-C filter is given as

$$f_c = \frac{1}{2\pi RC}$$

It is also called as an integration circuit.

- With the increasing frequency, low-frequency signal develops across the capacitor but signal of frequency above cut off frequency develops negligible voltage across the capacitor.
- At the cut-off frequency, the capacitive reactance of the capacitor is equal to the resistance of the resistor R, causing the output Voltage to be 0.707 times the input voltage (-3 dB) and the expected cut off frequency (f_c) of the low pass filter based on the circuit component Values.
- At zero frequency, the capacitor acts as an open circuit and output is same as the input.
- With the increase in frequency the capacitive reactance decreases and so the output voltage
- At infinite frequency, the capacitive reactance decreases and so the output voltage.
- At infinite frequency, the capacitive reactance of the circuit will be Zero and hence the output voltage will be Zero. Therefore it passes Low frequency signal and blocks the high frequency signal.

$$V_C(t) = \frac{1}{RC} \int R i(t) dt$$

function generator

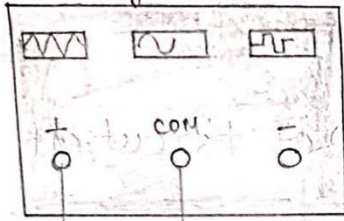

Bode Plotter

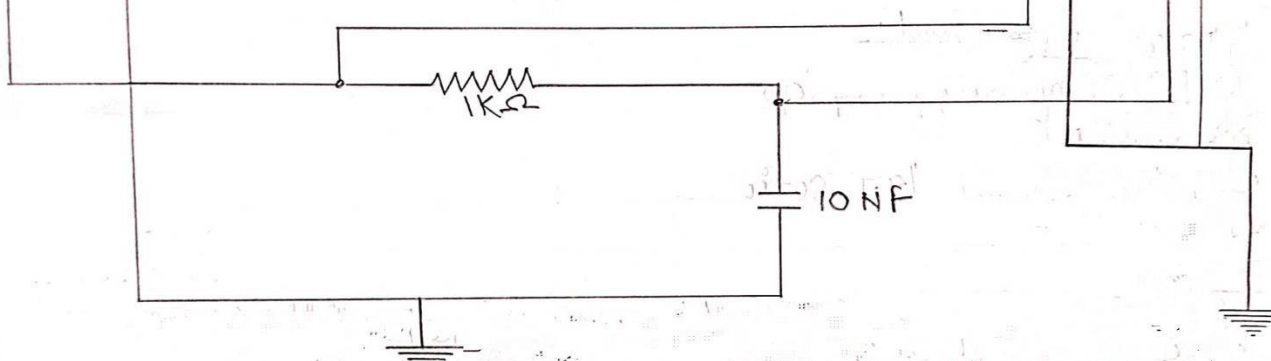
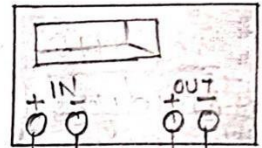

Schematic diagram for measuring cut-off frequency.

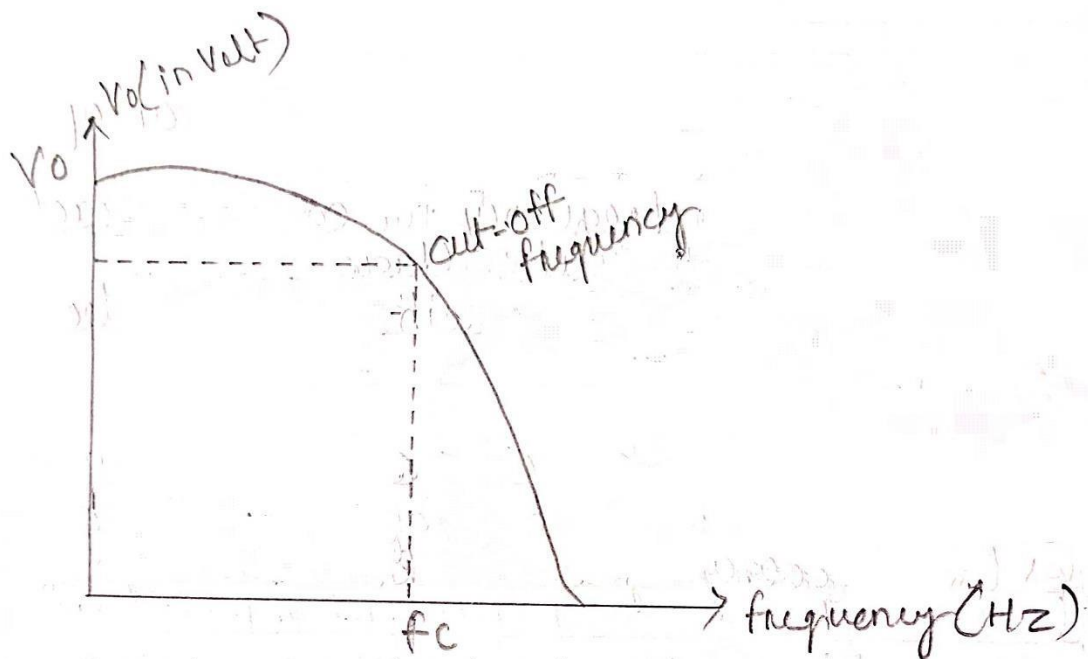

graph from Bode plotter

where $XC \ll R$, $V_{in}(t) = iR + \frac{V}{C} \cong iR$

$$V_c(t) = 1/RC \int V_{in}(t) dt$$

PROCEDURE: -

1. We should power on the computer and open. Ni mutism 14.1 Software
2. we should go to the place & Component - Select components as per our requirement for the Circuit diagram.
3. We should connect all the component as the circuit diagram and connect function generator for input signal and connect bode plotter for output graph.
4. we should run the circuit and check the bode plotter graph fore output and save the graph
5. We should close the NI Mutism window 14:1 software

CALCULATION: -

$$R = 1K \Omega$$

$$C = 0.01PF$$

$$FC = \frac{1}{2\pi RC} = \frac{1}{2 \times 10^3 \times 10^{-9}}$$

$$= 15913.43Hz$$

CONCLUSION: -

The above Experiment Done. Successfully.

EXPERIMENT - 10

AIM OF THE EXPERIMENT: -

Study of High Pass Filter and Determination of its Cut-off Frequency.

THEORY: -

A High Pass Filter (HPF) in an electronic filter that passes high frequency signals but attenuator Reduces the amplitude of signals with frequencies lower. Then the cut off frequency. The actual amount of attenuation for each frequency varies from filter of filter The frequency at which the output power again drops to 50% of the maximum value is called the cut off Frequency.

$$F_0 = \frac{1}{2\pi RC}$$

- When the filter dB voltage gain is plotted as a function of frequency of frequency on a semi log graph using socialite lines to approximate the actual frequency response it is called Bode plot.
- A bode plot is an ideal plot of filter frequency response because it assumes that the voltage gain remains contain uretic the cut-off frequency is reached.
- The high pass filter circuit, the reactance of the capacitor decreases with increase in frequency
- At high frequency the capacitor acts almost as a short circuit and virtually the input appears at the output.
- High pass filter is also called as differential Circuit.
- $V_{out} = VR + Vc = IR + 9/c = Vin$ When $R \ll 1/wc$ then $vin = 9/c$

$$dVm = \frac{1}{c} dq = \frac{1}{c} \frac{dq}{dt} \text{ and } I(t) = c \cdot \frac{dvin}{dt}$$

$$V_{out} = V_R = I(t)R = RC \cdot \frac{dvin}{dt}$$

FREQUENCY RESPONSE: -

It is a graph of magnitude of the output voltage of the filter as a function of the frequency. It is generally used to charact eristic the range of frequencies in which the filter in designed to operate within.

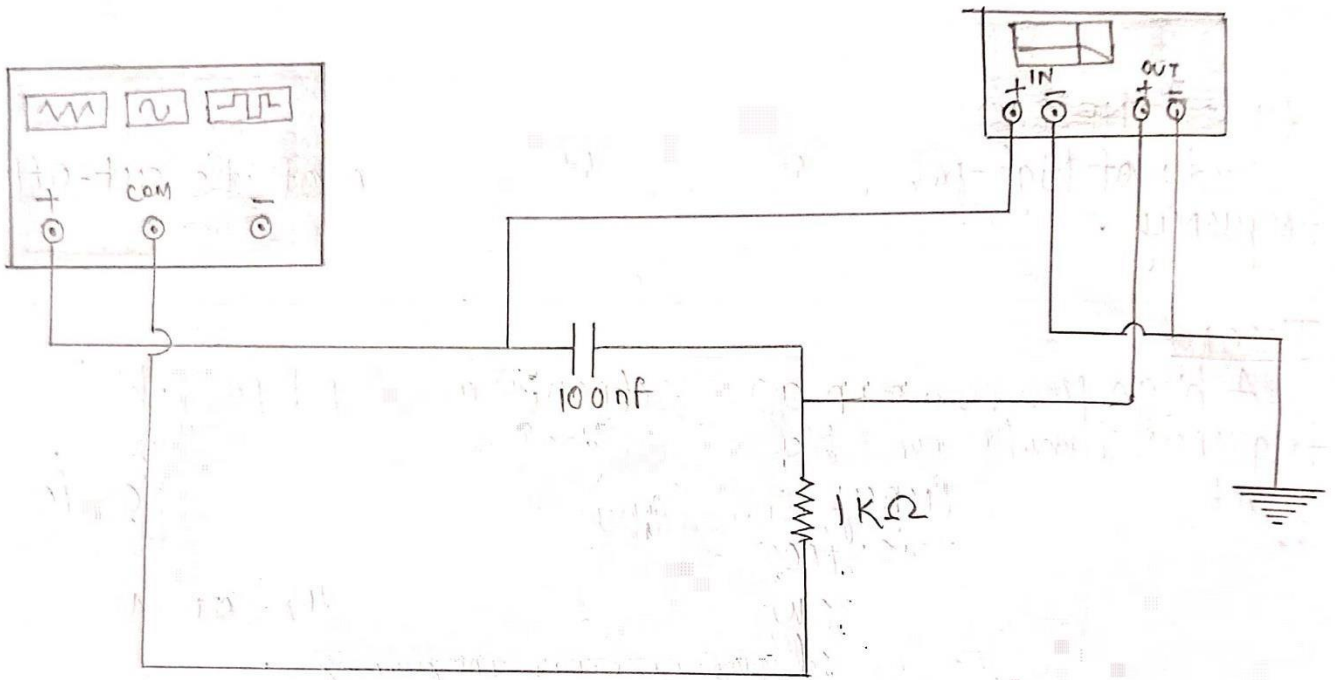

(High pass RC filter)

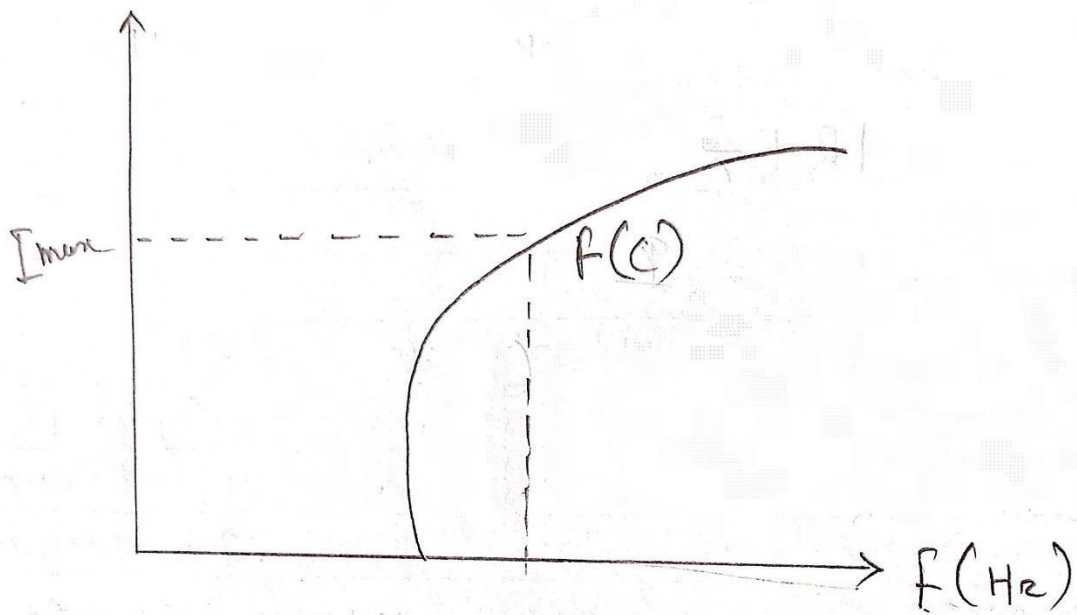

TYPES OF FILTERS:-

Filters which do not contain and active components are said to be passive are filters which contain active component on elements operational amplified and said to be active filter.

PROCEDURE: -

1. We should power on the computer and open NI Multisim 14.1 Software.
2. We should Component as to the place → Component select pen our requirement for the Circuit diagram.
3. We should cannot all the component as the circuit diagram and connect function
4. Generator for input signal and connect Bode plotter for output graph.
5. We should run the current and check-up Bode plotter graph fore output and save the graph
6. We should close the NT mutism window14.1 Software and shut down the computer.

CALCULATION: -

$$FC = \frac{1}{2\pi RC} R = 1 \text{ K}\Omega$$
$$= \frac{1}{2 \times 3.142 \times 1000 \times 100 \times 10^{-9} C} = 100 \text{ pf}$$
$$= 1591.3430 \text{ Hz}$$

CONCLUSION: -

The above experiment done Successfully

EXPERIMENT - 11

AIM OF THE EXPERIMENT: -

To study Band pass Band Element ion` filter and determine their cut off frequency.

APPARATUS REQUIRED:-

- Computer
- NI Multisim 14.1 Software
- Power Supply

THEORY: -

A band pass filter under ideal with zero attenuation in the pass band and offer infinite attenuation to frequencies Outside the pass band. There are 2 types of method to obtain band passing Conventional R-L-C filter method and use of a parallel Resonant circuit.

The cut off frequency
$$f_c = \frac{1}{2\pi\sqrt{LC}} \text{ Hz}$$

A Band stop or notch filter can be obtained by connecting in series a low-pass filter with High-pass filter such that the cut off Frequency f_2 of high pass filters is higher than the cut-off frequency f_1 of low pass filter.

The overlapping attenuation band of the two filters constitute the stop band of the band Elimination filter.

PROCEDURE: -

1. We should power on the computer and open NI Multisim 14.1 Software.
2. We should go to the place → component → select component as for our requirement for the circuit diagram
3. we should connect all the component as the circuit diagram and connect function generator for input signal and connect plotted for output graph.
4. We should run the circuit and check-up Bode plotter graph for output and save the graph.

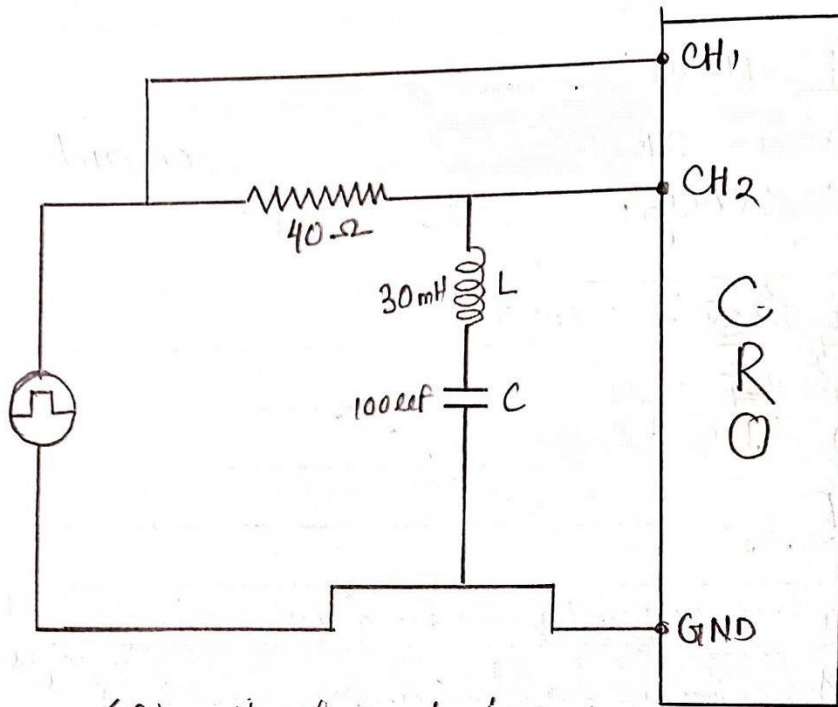

(Circuit of Band-elimination filter)

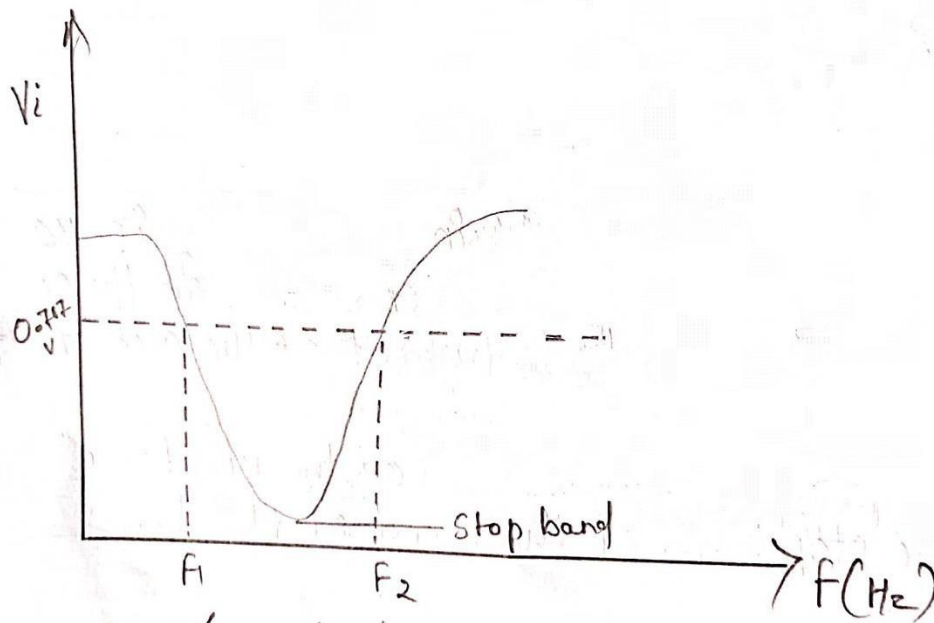

(graph of output)

5. We should close the NI mutism window 14.1 software and shutdown the computer.

CALCULATION:-

$$\begin{aligned} &= \frac{1}{\sqrt{LC}} \cdot 2\pi \\ &= \frac{1}{2 \times 3.142 \sqrt{30m \times 100\mu\text{F}}} \\ &= 91.87 \cong 92 \text{ Hz} \end{aligned}$$

CONCLUSION:-

The above experiment done successful.